

NOTICE OF FILING

This document was lodged electronically in the FEDERAL COURT OF AUSTRALIA (FCA) on 28/07/2020 10:50:37 PM AEST and has been accepted for filing under the Court's Rules. Details of filing follow and important additional information about these are set out below.

Details of Filing

Document Lodged: Court Book
File Number: NSD714/2020
File Title: WELLS FARGO TRUST COMPANY, NATIONAL ASSOCIATION (AS OWNER TRUSTEE) & ANOR v VB LEASECO PTY LTD (ADMINISTRATORS APPOINTED) ACN 134 268 741 & ORS
Registry: NEW SOUTH WALES REGISTRY - FEDERAL COURT OF AUSTRALIA



Sia Lagos

Dated: 29/07/2020 8:59:37 AM AEST

Registrar

Important Information

As required by the Court's Rules, this Notice has been inserted as the first page of the document which has been accepted for electronic filing. It is now taken to be part of that document for the purposes of the proceeding in the Court and contains important information for all parties to that proceeding. It must be included in the document served on each of those parties.

The date and time of lodgment also shown above are the date and time that the document was received by the Court. Under the Court's Rules the date of filing of the document is the day it was lodged (if that is a business day for the Registry which accepts it and the document was received by 4.30 pm local time at that Registry) or otherwise the next working day for that Registry.



ASIC EXTRACT SNAPSHOT

CURRENT ORGANISATION DETAILS

Date Extracted	22/06/2020
ACN	134 268 741
ABN	29 134 268 741
Current Name	VB LEASECO PTY LTD
Registered In	Victoria
Registration Date	20/11/2008
Review Date	27/05/2021
Company Type	ACN (Australian Company Number)
Current Directors	2
Current Secretaries	1

Start Date	20/04/2020
Name	VB LEASECO PTY LTD
Name Start Date	20/11/2008
Status	** Under External Administration And/Or Controller Appointed **
Type	Australian Proprietary Company
Class	Limited By Shares
Sub Class	Proprietary Company
Disclosing Entity	No
Document No.	

Share Structure (Displaying Top 4 Only)

[Go to Full ASIC Results](#)

Class	Class Type	Shares Issued	Amount Paid
ORD	ORDINARY SHARES	1	\$1.00

(creditor)watch - Credit Score (69)

[Go to Full Credit Report](#)



Risk Data Summary

Court Judgments	0	Payment Defaults	0	Insolvency Notices	2	Mercantile Enquiries	0	Credit Enquiries	58
-----------------	---	------------------	---	--------------------	---	----------------------	---	------------------	----

REVEAL - Company Visualisation

[Go to full workspace](#)

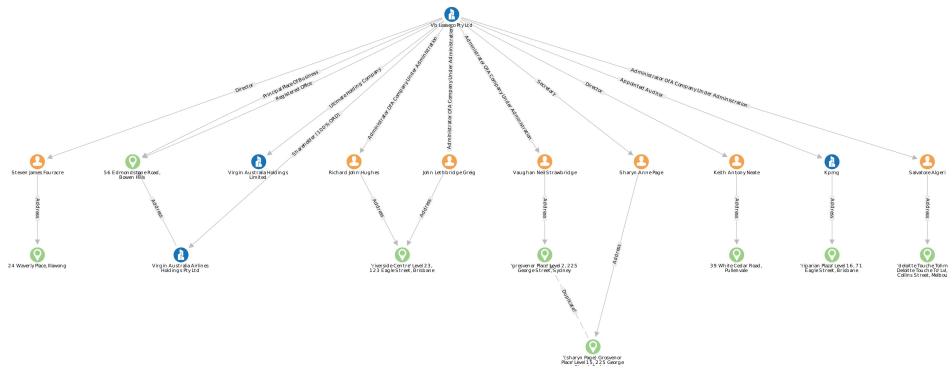

ASIC Data Extracted 22/06/2020 at 08:56

This extract contains information derived from the Australian Securities and Investment Commission's (ASIC) database under section 1274A of the Corporations Act 2001. Please advise ASIC of any error or omission which you may identify.

- 134 268 741 VB LEASECO PTY LTD -

ACN (Australian Company Number):	134 268 741	Document No.
ABN:	29 134 268 741	
Current Name:	VB LEASECO PTY LTD	
Registered in:	Victoria	
Registration Date:	20/11/2008	
Review Date:	27/05/2021	
Company Bounded By:		

- Current Organisation Details -

Name: VB LEASECO PTY LTD
Name Start Date: 20/11/2008
Status: ** Under External Administration And/Or Controller Appointed **
Type: Australian Proprietary Company
Class: Limited By Shares
Sub Class: Proprietary Company

- Company Addresses -

- Registered Office 025291089
Address: 56 EDMONDSTONE ROAD BOWEN HILLS QLD 4006
Start Date: 20/11/2008

- Principal Place of Business 025291089
Address: 56 EDMONDSTONE ROAD BOWEN HILLS QLD 4006
Start Date: 20/11/2008

- Company Officers -

Note:

A date or address shown as UNKNOWN has not been updated since ASIC took over the records in 1991. For details, order the appropriate historical state or territory documents, available in microfiche or paper format.

* Check documents listed under ASIC Documents Received for recent changes.

[Directors](#)

Name: STEVEN JAMES FOURACRE 7E9709150
Address: 24 WAVERLY PLACE ILLAWONG NSW 2234
Birth Details: 26/10/1966 CANBERRA ACT
Appointment Date: 24/11/2017
Cease Date: //

Name: KEITH ANTONY NEATE 7EAQ31225
Address: 39 WHITE CEDAR ROAD PULLENVALE QLD 4069
Birth Details: 05/10/1961 LOWER KINGSWOOD UNITED KINGDOM
Appointment Date: 01/10/2019
Cease Date: //

Secretaries

Name: SHARYN ANNE PAGE 7E7704657
Address: '(SHARYN PAGE) GROSVENOR PLACE' LEVEL 15 225 GEORGE STREET
SYDNEY NSW 2000
Birth Details: 07/01/1963 WAGGA WAGGA NSW
Appointment Date: 01/02/2016
Cease Date: //

Appointed Auditors

Name: 024 510 530 KPMG 7E3447196
Address: 'RIPARIAN PLAZA' LEVEL 16 71 EAGLE STREET BRISBANE QLD 4000 (FR 2010)
Appointment Date: 20/11/2008
Cease Date: //

Ultimate Holding Company

Name: 100 686 226 VIRGIN AUSTRALIA HOLDINGS LIMITED 025291089
Address:
Appointment Date: //
Cease Date: //
Abn: 54 100 686 226

Administrator of a Company under Administration

Name: RICHARD JOHN HUGHES 7EAV78323
Address: DELOITTE TOUCHE TOHMATSU 'RIVERSIDE CENTRE' LEVEL 23 123 EAGLE
STREET BRISBANE QLD 4000
Birth Details: //
Appointment Date: 20/04/2020
Cease Date: //

Name: JOHN LETHBRIDGE GREIG 7EAV78323
Address: DELOITTE TOUCHE TOHMATSU 'RIVERSIDE CENTRE' LEVEL 23 123 EAGLE STREET BRISBANE QLD 4000
Birth Details: //
Appointment Date: 20/04/2020
Cease Date: //

Name: VAUGHAN NEIL STRAWBRIDGE 7EAV78323
Address: C/- DELOITTE TOUCHE TOHMATSU 'GROSVENOR PLACE' LEVEL 2 225 GEORGE STREET SYDNEY NSW 2000
Birth Details: //
Appointment Date: 20/04/2020
Cease Date: //

Name: SALVATORE ALGERI 7EAW57466
Address: DELOITTE TOUCHE TOHMATSU 'DELOITTE TOUCHE TOHMATSU DELOITTE TOUCHE TO' LVL 477 COLLINS STREET MELBOURNE VIC 3000
Birth Details: //
Appointment Date: 20/04/2020
Cease Date: //

- Share Structure -

Current

Class: ORDINARY SHARES 025291089
Number of Shares Issued: 1
Total Amount Paid / Taken to be Paid: \$1.00
Total Amount Due and Payable: \$0.00

Note:

For each class of shares issued by a company, ASIC records the details of the twenty members of the class (based on shareholdings). The details of any other members holding the same number of shares as the twentieth ranked member will also be recorded by ASIC on the database. Where available, historical records show that a member has ceased to be ranked amongst the twenty members. This may, but does not necessarily mean, that they have ceased to be a member of the company.

- Share/Interest Holding -

Current

- Holding -

Class: ORD **Number Held:** 1 025291089
Beneficially Owned: Yes **Fully Paid:** Yes

- Members -

Name: VIRGIN AUSTRALIA AIRLINES HOLDINGS PTY LTD
ACN: 093 924 675
Address: 56 EDMONDSTONE ROAD BOWEN HILLS QLD 4006
Joint Holding: No
Abn: 19 093 924 675

- External Administration Documents -

Note:

Documents relating to External Administration and/or appointment of Controller.

This extract may not list all documents relating to this status. State and Territory records should be searched.

Form Type	Description	Date Lodged	Processed	No. Pages	Document No.
5011		20/06/2020	20/06/2020	38	7EAX68598
5011A	COPY OF MINUTES OF MEETING OF MEMBERS, CREDITORS, CONTRIBUTORIES OR COMMITTEE OF INSPECTION OTHER THAN UNDER S.436E OR S.439A				
506		18/05/2020	18/05/2020	4	7EAW57466
506L	NOTIFICATION OF CHANGE OF ADDRESS OF NOTIFICATION OF CHANGE OF ADDRESS OF AN EXTERNAL ADMINISTRATOR OR CONTROLLER OR SCHEME ADMINISTRATOR				
5011		11/05/2020	11/05/2020	56	7EAW38772
5011B	COPY OF MINUTES OF MEETING OF MEMBERS, CREDITORS, CONTRIBUTORIES OR COMMITTEE OF INSPECTION UNDER S.436E OR S.439A				
531		22/04/2020	22/04/2020	14	7EAV82165
531A	DECLARATION OF RELEVANT RELATIONSHIPS AND/OR INDEMNITY COPY OF A DIRRI				
505		21/04/2020	21/04/2020	3	7EAV78323
505U	NOTICE BY EXTERNAL ADMINISTRATOR/CONTROLLER-APPOINT/CEASE APPT OF ADMINISTRATOR UNDER S.436A, 436B, 436C, 436E(4), 449B, 449C(1), 449C(4) OR 449(6)				

- Charges -

There are no charges held for this organisation.

Notes:

On 30 January 2012, the Personal Property Securities Register (PPS Register) commenced.

At that time ASIC transferred all details of current charges to the PPS Registrar.

ASIC can only provide details of satisfied charges prior to that date.

Details of current charges, or charge satisfied since 30 January 2012 can be found on the PPS Register, www.ppsr.gov.au.

InfoTrack may cap documents for on-file searches to 250.

- Document List -

Notes:

- * Documents already listed under Registered Charges are not repeated here.
- * Data from Documents with no Date Processed are not included in this Extract.
- * Documents with '0' pages have not yet been imaged and are not available via DOCIMAGE. Imaging takes approximately 2 weeks from date of lodgement.
- * The document list for a current/historical extract will be limited unless you requested ALL documents for this extract.
- * In certain circumstances documents may be capped at 250.

Form Type	Date Received	Date Processed	No. Pages	Effective Date	Document No.
484 484E	15/10/2019	15/10/2019	2	15/10/2019	7EAQ31225
	Change to Company Details Appointment or Cessation of A Company Officeholder				
484 484E	04/12/2017	04/12/2017	2	04/12/2017	7E9709150
	Change to Company Details Appointment or Cessation of A Company Officeholder				
484 484E	25/11/2016	25/11/2016	2	25/11/2016	7E8562265
	Change to Company Details Appointment or Cessation of A Company Officeholder				
484 484E	16/02/2016	16/02/2016	2	16/02/2016	7E7704657
	Change to Company Details Appointment or Cessation of A Company Officeholder				
484 484E	01/10/2015	01/10/2015	2	01/10/2015	7E7350419
	Change to Company Details Appointment or Cessation of A Company Officeholder				
389 389B	06/06/2014	13/06/2014	3	06/06/2014	029022093
	Annual Notice By Wholly-Owned Entity Annual Notice By Wholly-Owned Entity - Companies				
352 352	06/06/2014	13/06/2014	8	06/06/2014	029022092
	Assumption Deed Relating to Class Order				
388 388H	31/10/2013	31/10/2013	45	30/06/2013	7E5617745
	Financial Report Financial Report - Large Proprietary Company That Is Not a Disclosing Entity				
484 484 484A1 484E	31/10/2013	31/10/2013	3	31/10/2013	7E5615883
	Change to Company Details Change Officeholder Name or Address Appointment or Cessation of a Company Officeholder				
484 484A1	04/04/2013	04/04/2013	2	04/04/2013	7E5129862
	Change to Company Details Change Officeholder Name Or Address				
484 484A1	14/03/2013	14/03/2013	2	14/03/2013	7E5086753
	Change to Company Details Change Officeholder Name Or Address				

388 388H	31/10/2012	31/10/2012	41	30/06/2012	7E4820323
	Financial Report Financial Report - Large Proprietary Company That Is Not a Disclosing Entity				
484 484A1	22/06/2012	22/06/2012	2	22/06/2012	7E4536147
	Change to Company Details Change Officeholder Name Or Address				
309 309A	14/12/2011	16/12/2011	26	12/12/2011	027189789
	Notification of Details of a Charge				
388 388H	05/12/2011	05/12/2011	42	30/06/2011	7E4134706
	Financial Report Financial Report - Large Proprietary Company That Is Not a Disclosing Entity				
309 309A	05/12/2011	06/12/2011	70	22/11/2011	027189744
	Notification of Details of a Charge				
309 309A	05/12/2011	06/12/2011	72	22/11/2011	027189743
	Notification of Details of a Charge				
309 309A	05/12/2011	06/12/2011	21	22/11/2011	027189742
	Notification of Details of a Charge				
309 309A	18/10/2011	19/10/2011	27	14/10/2011	027189603
	Notification of Details of a Charge				
484 484A1	26/09/2011	26/09/2011	3	26/09/2011	027788377
	Change to Company Details Change Officeholder Name Or Address				
309 309A	29/08/2011	31/08/2011	63	05/08/2011	027747393
	Notification of Details of a Charge				
484 484E	18/07/2011	18/07/2011	4	18/07/2011	027705244
	Change to Company Details Appointment or Cessation of A Company Officeholder				
309 309A	17/06/2011	20/06/2011	27	08/06/2011	027189110
	Notification of Details of a Charge				
484 484A1	10/06/2011	10/06/2011	2	10/06/2011	7E3729889
	Change to Company Details Change Officeholder Name Or Address				
484 484E	20/05/2011	20/05/2011	2	20/05/2011	7E3681352
	Change to Company Details Appointment or Cessation of A Company Officeholder				
309 309A	04/05/2011	05/05/2011	27	18/04/2011	026016381
	Notification of Details of a Charge				
312	04/05/2011	05/05/2011	2	04/05/2011	026016379

312A	Notification of Discharge				
488	27/04/2011	18/05/2011	6	27/04/2011	026621237
488M	Application to Change Review Date of a Company or Scheme Synchronise Review Date With Holding Company - No Fee				
309	27/04/2011	28/04/2011	24	18/04/2011	027188992
309A	Notification of Details of a Charge				
312	04/04/2011	05/04/2011	2	04/04/2011	026016276
312A	Notification of Discharge				
309	04/04/2011	05/04/2011	63	28/03/2011	027457855
309A	Notification of Details of a Charge				
309	31/03/2011	01/04/2011	27	25/03/2011	026016196
309A	NOTIFICATION OF DETAILS OF A CHARGE				
484	23/03/2011	23/03/2011	2	23/03/2011	7E3558145
484A1	CHANGE TO COMPANY DETAILS CHANGE OFFICEHOLDER NAME OR ADDRESS				
484	18/03/2011	18/03/2011	4	18/03/2011	026037047
484E	CHANGE TO COMPANY DETAILS APPOINTMENT OR CESSATION OF A COMPANY OFFICEHOLDER				
309	15/03/2011	16/03/2011	24	11/03/2011	026026801
309A	NOTIFICATION OF DETAILS OF A CHARGE				
309	15/03/2011	16/03/2011	40	11/03/2011	026026800
309A	NOTIFICATION OF DETAILS OF A CHARGE				
309	15/03/2011	16/03/2011	24	11/03/2011	026026795
309A	NOTIFICATION OF DETAILS OF A CHARGE				
309	15/03/2011	16/03/2011	38	11/03/2011	026026794
309A	NOTIFICATION OF DETAILS OF A CHARGE				
484	10/03/2011	10/03/2011	2	10/03/2011	7E3528713
484E	CHANGE TO COMPANY DETAILS APPOINTMENT OR CESSATION OF A COMPANY OFFICEHOLDER				
309	09/03/2011	10/03/2011	24	03/03/2011	026016165
309A	NOTIFICATION OF DETAILS OF A CHARGE				
309	15/02/2011	16/02/2011	63	07/02/2011	027468212
309A	NOTIFICATION OF DETAILS OF A CHARGE				
388	02/02/2011	02/02/2011	41	30/06/2010	7E3447196
388	FINANCIAL REPORT				
388H	FINANCIAL REPORT - LARGE PROPRIETARY COMPANY THAT IS NOT A DISCLOSING ENTITY				
388E	COMPANY - APPOINT CHANGE NAME/ADDRESS OF AUDITOR				

484 484E	17/01/2011	17/01/2011	3	17/01/2011	7E3417115
	CHANGE TO COMPANY DETAILS APPOINTMENT OR CESSATION OF A COMPANY OFFICEHOLDER				
484 484E	26/11/2010	26/11/2010	2	26/11/2010	7E3322502
	CHANGE TO COMPANY DETAILS APPOINTMENT OR CESSATION OF A COMPANY OFFICEHOLDER				
484 484E	24/05/2010	31/05/2010	4	24/05/2010	026664008
	CHANGE TO COMPANY DETAILS APPOINTMENT OR CESSATION OF A COMPANY OFFICEHOLDER				
484 484E	12/05/2010	12/05/2010	2	12/05/2010	7E2886867
	CHANGE TO COMPANY DETAILS APPOINTMENT OR CESSATION OF A COMPANY OFFICEHOLDER				
309 309A	29/04/2010	30/04/2010	77	19/04/2010	024979228
	NOTIFICATION OF DETAILS OF A CHARGE				
309 309A	29/04/2010	30/04/2010	65	19/04/2010	024979230
	NOTIFICATION OF DETAILS OF A CHARGE				
309 309A	29/04/2010	30/04/2010	79	19/04/2010	024979231
	NOTIFICATION OF DETAILS OF A CHARGE				
484 484E	26/03/2010	26/03/2010	2	26/03/2010	7E2793100
	CHANGE TO COMPANY DETAILS APPOINTMENT OR CESSATION OF A COMPANY OFFICEHOLDER				
484 484E	28/01/2010	28/01/2010	2	28/01/2010	7E2674883
	CHANGE TO COMPANY DETAILS APPOINTMENT OR CESSATION OF A COMPANY OFFICEHOLDER				
309 309A	18/09/2009	21/09/2009	41	15/09/2009	024981366
	NOTIFICATION OF DETAILS OF A CHARGE				
309 309A	18/09/2009	21/09/2009	38	16/09/2009	024981365
	NOTIFICATION OF DETAILS OF A CHARGE				
484 484A1	29/05/2009	29/05/2009	2	29/05/2009	7E2215535
	CHANGE TO COMPANY DETAILS CHANGE OFFICEHOLDER NAME OR ADDRESS				
309 309A	29/04/2009	30/04/2009	43	21/04/2009	025003521
	NOTIFICATION OF DETAILS OF A CHARGE				
309 309A	02/02/2009	03/02/2009	65	23/01/2009	025003233
	NOTIFICATION OF DETAILS OF A CHARGE				
309 309A	02/02/2009	03/02/2009	68	23/01/2009	025003236
	NOTIFICATION OF DETAILS OF A CHARGE				
309 309A	02/02/2009	03/02/2009	53	23/01/2009	025003238
	NOTIFICATION OF DETAILS OF A CHARGE				

484	02/01/2009	02/01/2009	3	02/01/2009	7E1970823
484E	CHANGE TO COMPANY DETAILS APPOINTMENT OR CESSATION OF A COMPANY OFFICEHOLDER				
201	20/11/2008	20/11/2008	8	20/11/2008	025291089
201C	APPLICATION FOR REGISTRATION AS A PROPRIETARY COMPANY				

- Financial Reports -

Document No.	Balance Date	Report Due	AGM Due	Extended AGM Due	AGM Held	Outstanding
7E3447196	30/06/2010	31/10/2010	//	//	//	No
7E4134706	30/06/2011	31/10/2011	//	//	//	No
7E4820323	30/06/2012	31/10/2012	//	//	//	No
7E5617745	30/06/2013	31/10/2013	//	//	//	No

- Company Contact Addresses -

- Contact Address for ASIC use only

Address: LEVEL 5 7-15 MACQUARIE PLACE SYDNEY NSW 2000
Start Date: 26/09/2011

*** End of Document ***

Risk Data

Summary

Organisation Status:	Under External Administration And/Or Controller Appointed
Court Actions:	0
Payment Defaults:	0
ASIC Published Notices:	2
Mercantile Enquiries:	0
Critical ASIC Documents:	5
Credit Score:	69
Credit Enquiries - Last 5 Years:	58
Credit Enquiries - Last 12 Months:	25

Status Changes

ASIC Entity Status Changes

Change Date	ASIC Changes
20-04-2020	Under External Administration And/Or Controller Appointed (Current status)
20-11-2008	Registered

Credit Report

Court Actions

Plaintiff	Action	Action Amount	Action Date	Nature of claim	Proceeding #	Location
-----------	--------	---------------	-------------	-----------------	--------------	----------

There are currently no court actions registered.

Court action information is supplied to CreditorWatch by the courts. We rely on the courts to provide up to date and accurate information and therefore CreditorWatch cannot guarantee that all actions are included. This report includes action information from the Magistrates courts in NSW, QLD, SA, VIC, and WA.

Payment Defaults

Default Posted By	Document Type	Amount Outstanding	Date Added	Payment Due Date	Part Payment Made	Default Settled
-------------------	---------------	--------------------	------------	------------------	-------------------	-----------------

There are currently no defaults registered.

ASIC Published Notices

Date	Title
04-06-2020	NOTICE OF MEETING OF MEMBERS OF COMMITTEE OF INSPECTION

Date	Title
21-04-2020	COMBINED NOTICE OF APPOINTMENT AND FIRST MEETING OF CREDITORS OF COMPANY UNDER ADMINISTRATION

Registered Mercantile Enquiries

Enquiry Date	Mercantile Agent
--------------	------------------

There are no mercantile enquiries registered.

Credit Score

The score is a statistically based score indicating an entity's credit worthiness. The score ultimately ranks entities based on their riskiness and is designed to assist you in making more informed and consistent credit decisions.

The score is based between 0 and 850 index points with a higher score considered lower risk while lower scores are deemed to be riskier entities. It should be used in partnership with your internal credit procedures and policies.

Entity has a critical status and significant adverse information present. Trading eligibility must be considered. Entity has a 71.81% chance of failure within the next 12 months.



Historical Credit Scores

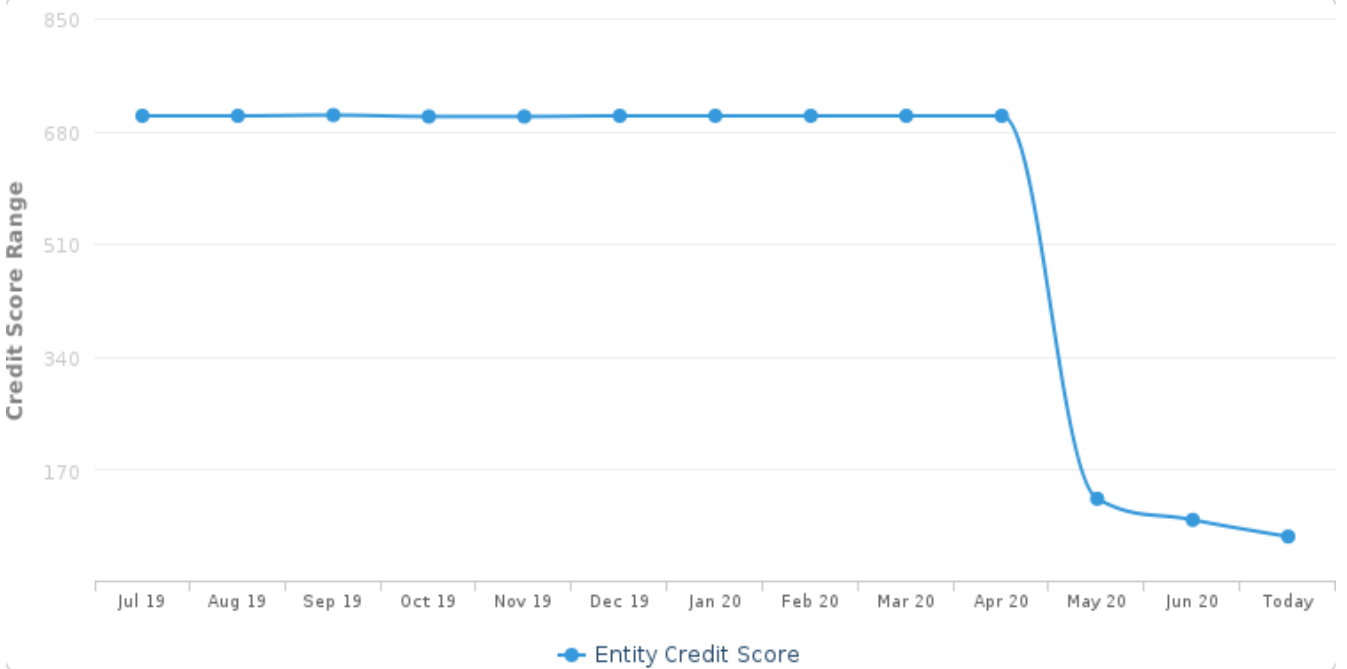

Recommendations

Range	Risk level	Recommendation
0	Critical	ACN deregistered or ABN cancelled.
1 - 125	Critical	Entity has a critical status and significant adverse information present. Trading eligibility must be considered.
126 - 250	Very High	Entity has multiple pieces of adverse information present. COD trading highly recommended.
251 - 450	High	Entity has a below average creditworthiness score and some adverse information may be present. Trade with caution, monitor closely and consider your payment terms.
451 - 550	Moderate	Entity has moderate creditworthiness with or without adverse information. Monitor ongoing payment behaviour.
551 - 850	Low	Entity has acceptable creditworthiness. Extend terms within consideration.

score v.20150123a

Please note that the score and recommendation should be used in partnership with your company's internal credit procedures and policies. The

score should not be used as the sole reason in making a decision about the entity.

Credit Enquiries

Entity has 58 credit enquiries within the last 5 years.
Entity has 25 credit enquiries within the last 12 months.

Credit Enquiries (Last 12 Months)

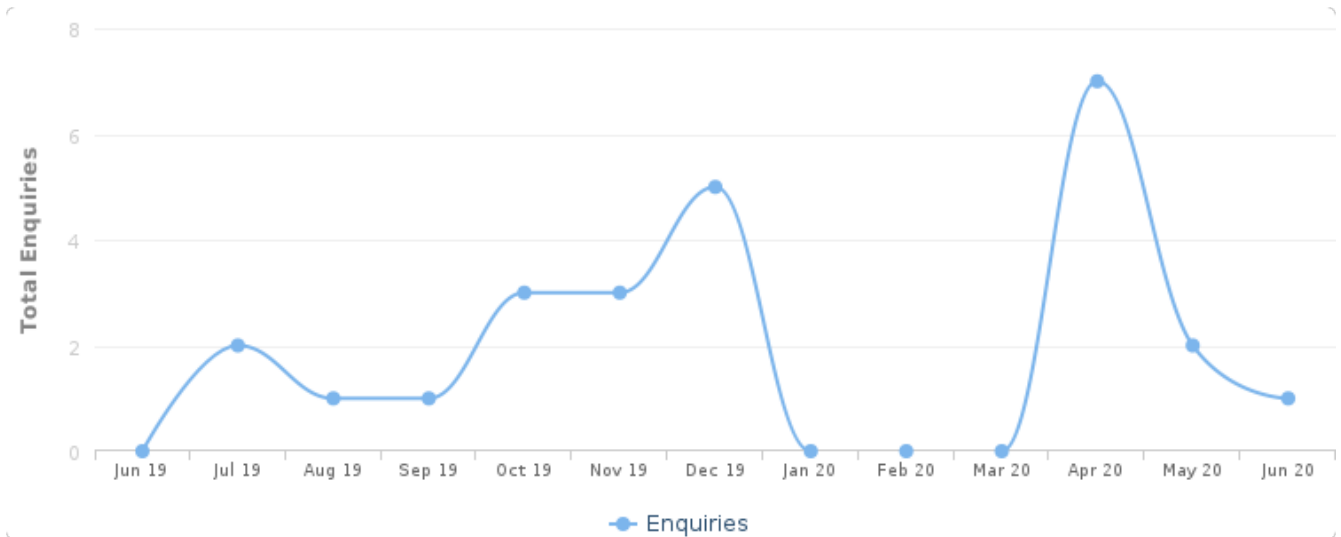

Ordered by Industry (Last 12 Months)

Industry	Number of Enquiries
Professional, Scientific and Technical Services (M)	25
TOTAL ENQUIRIES	25

Ordered by Date (Last 12 Months)

Industry	Date
Professional, Scientific and Technical Services (M)	22-06-2020
Professional, Scientific and Technical Services (M)	29-05-2020
Professional, Scientific and Technical Services (M)	04-05-2020
Professional, Scientific and Technical Services (M)	27-04-2020
Professional, Scientific and Technical Services (M)	22-04-2020
Professional, Scientific and Technical Services (M)	21-04-2020
Professional, Scientific and Technical Services (M)	20-04-2020
Professional, Scientific and Technical Services (M)	17-04-2020
Professional, Scientific and Technical Services (M)	15-04-2020
Professional, Scientific and Technical Services (M)	09-04-2020
Professional, Scientific and Technical Services (M)	24-12-2019

Industry	Date
Professional, Scientific and Technical Services (M)	23-12-2019
Professional, Scientific and Technical Services (M)	19-12-2019
Professional, Scientific and Technical Services (M)	18-12-2019
Professional, Scientific and Technical Services (M)	02-12-2019
Professional, Scientific and Technical Services (M)	13-11-2019
Professional, Scientific and Technical Services (M)	07-11-2019
Professional, Scientific and Technical Services (M)	06-11-2019
Professional, Scientific and Technical Services (M)	30-10-2019
Professional, Scientific and Technical Services (M)	25-10-2019
Professional, Scientific and Technical Services (M)	10-10-2019
Professional, Scientific and Technical Services (M)	17-09-2019
Professional, Scientific and Technical Services (M)	30-08-2019
Professional, Scientific and Technical Services (M)	23-07-2019
Professional, Scientific and Technical Services (M)	03-07-2019

Historical Timeline

Date	Type	Notes
21-05-2020	ASIC Document	#7EAX68598 Form 5011 Copy of Minutes of Meeting of Members, Creditors, Contributories or Committee of Inspection Other Than Under S.436e or S.439a
18-05-2020	ASIC Document	#7EAW57466 Form 506 Notification of Change of Address of Notification of Change Of Address of an External Administrator or Controller Or Scheme Administrator
30-04-2020	ASIC Document	#7EAW38772 Form 5011 Copy of Minutes of Meeting of Members, Creditors, Contributories or Committee of Inspection Under S.436e Or S.439a
20-04-2020	Status	The ASIC status was changed to Under External Administration And/Or Controller Appointed
20-04-2020	ASIC Document	#7EAV82165 Form 531 Declaration of Relevant Relationships And/or Indemnity Copy Of a Dirri #7EAV78323 Form 505 Notice By External Administrator/controller-Appoint/cease Appt of Administrator Under S.436a, 436b, 436c, 436e(4), 449b, 449c(1), 449c(4) or 449(6)
15-10-2019	ASIC Document	#7EAQ31225 Form 484 Change to Company Details Appointment or Cessation of A Company Officeholder
04-12-2017	ASIC Document	#7E9709150 Form 484 Change to Company Details Appointment or Cessation of A Company Officeholder
25-11-2016	ASIC Document	#7E8562265 Form 484 Change to Company Details Appointment or Cessation of A Company Officeholder
16-02-2016	ASIC Document	#7E7704657 Form 484 Change to Company Details Appointment or Cessation of A Company Officeholder
01-10-2015	ASIC Document	#7E7350419 Form 484 Change to Company Details Appointment or Cessation of A Company Officeholder
06-06-2014	ASIC Document	#029022093 Form 389 Annual Notice By Wholly-Owned Entity Annual Notice By Wholly-Owned Entity - Companies #029022092 Form 352 Assumption Deed Relating to Class Order
31-10-2013	ASIC Document	#7E5615883 Form 484 Change to Company Details Change Officeholder Name or Address Appointment or Cessation of a Company Officeholder
30-06-2013	ASIC Document	#7E5617745 Form 388 Financial Report Financial Report - Large Proprietary Company That Is Not a Disclosing Entity
04-04-2013	ASIC Document	#7E5129862 Form 484 Change to Company Details Change Officeholder Name Or Address
14-03-2013	ASIC Document	#7E5086753 Form 484 Change to Company Details Change Officeholder Name Or Address
30-06-2012	ASIC Document	#7E4820323 Form 388 Financial Report Financial Report - Large Proprietary Company That Is Not a Disclosing Entity

Date	Type	Notes
22-06-2012	ASIC Document	#7E4536147 Form 484 Change to Company Details Change Officeholder Name Or Address
12-12-2011	ASIC Document	#027189789 Form 309 Notification of Details of a Charge
22-11-2011	ASIC Document	#027189744 Form 309 Notification of Details of a Charge #027189743 Form 309 Notification of Details of a Charge #027189742 Form 309 Notification of Details of a Charge
14-10-2011	ASIC Document	#027189603 Form 309 Notification of Details of a Charge
26-09-2011	ASIC Document	#027788377 Form 484 Change to Company Details Change Officeholder Name Or Address
05-08-2011	ASIC Document	#027747393 Form 309 Notification of Details of a Charge
18-07-2011	ASIC Document	#027705244 Form 484 Change to Company Details Appointment or Cessation of A Company Officeholder
30-06-2011	ASIC Document	#7E4134706 Form 388 Financial Report Financial Report - Large Proprietary Company That Is Not a Disclosing Entity
10-06-2011	ASIC Document	#7E3729889 Form 484 Change to Company Details Change Officeholder Name Or Address
08-06-2011	ASIC Document	#027189110 Form 309 Notification of Details of a Charge
20-05-2011	ASIC Document	#7E3681352 Form 484 Change to Company Details Appointment or Cessation of A Company Officeholder
04-05-2011	ASIC Document	#026016379 Form 312 Notification of Discharge
27-04-2011	ASIC Document	#026621237 Form 488 Application to Change Review Date of a Company or Scheme Synchronise Review Date With Holding Company - No Fee
18-04-2011	ASIC Document	#026016381 Form 309 Notification of Details of a Charge #027188992 Form 309 Notification of Details of a Charge
04-04-2011	ASIC Document	#026016276 Form 312 Notification of Discharge
28-03-2011	ASIC Document	#027457855 Form 309 Notification of Details of a Charge
25-03-2011	ASIC Document	#026016196 Form 309 Notification of Details of a Charge
23-03-2011	ASIC Document	#7E3558145 Form 484 Change to Company Details Change Officeholder Name Or Address

Date	Type	Notes
18-03-2011	ASIC Document	#026037047 Form 484 Change to Company Details Appointment or Cessation of A Company Officeholder
11-03-2011	ASIC Document	#026026801 Form 309 Notification of Details of a Charge #026026800 Form 309 Notification of Details of a Charge #026026795 Form 309 Notification of Details of a Charge #026026794 Form 309 Notification of Details of a Charge
10-03-2011	ASIC Document	#7E3528713 Form 484 Change to Company Details Appointment or Cessation of A Company Officeholder
03-03-2011	ASIC Document	#026016165 Form 309 Notification of Details of a Charge
07-02-2011	ASIC Document	#027468212 Form 309 Notification of Details of a Charge
17-01-2011	ASIC Document	#7E3417115 Form 484 Change to Company Details Appointment or Cessation of A Company Officeholder
26-11-2010	ASIC Document	#7E3322502 Form 484 Change to Company Details Appointment or Cessation of A Company Officeholder
30-06-2010	ASIC Document	#7E3447196 Form 388 Financial Report Financial Report - Large Proprietary Company That Is Not A Disclosing Entity Company - Appoint Change Name/address of Auditor
20-11-2008	Entity Status	The Entity Status was changed to Active
20-11-2008	Goods And Services Tax	The Goods and Services Tax was changed to Currently registered for GST
20-11-2008	Main Name	The Main Name was changed to VB LEASECO PTY LTD
20-11-2008	Main Business Physical Address	The Main Business Physical Address was changed to QLD 4006

Disclaimer

CreditorWatch is committed to ensuring that the information provided is accurate and comprehensive however due to data being received from sources not controlled by CreditorWatch we cannot guarantee that it is complete, verified or free of errors. The information should therefore be used in conjunction with your own investigations and you should not rely solely on this information when making credit or financial decisions. To the extent permitted by law, CreditorWatch will not be held responsible for any errors or omissions therein concerning the information sourced and published in its publications, websites, API or emails.

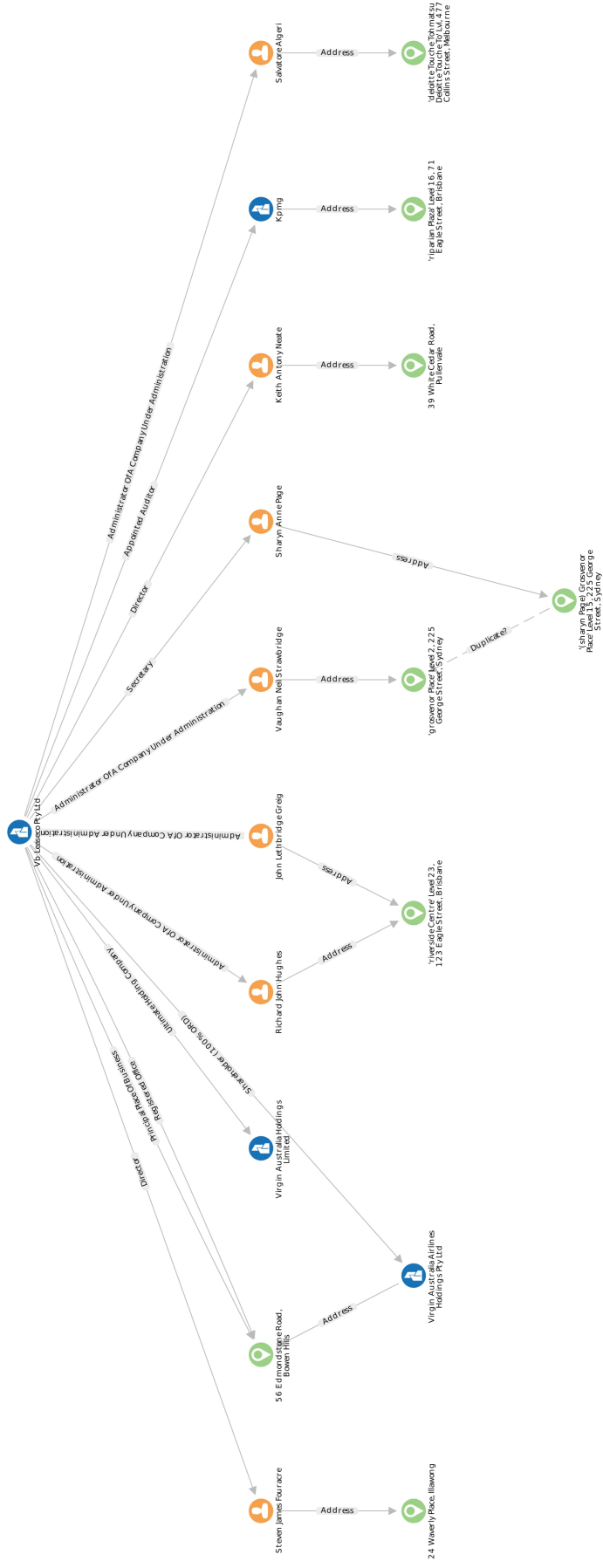

ASIC EXTRACT SNAPSHOT

CURRENT ORGANISATION DETAILS

Date Extracted 22/06/2020
 ACN 090 670 965
 ABN 36 090 670 965
 Current Name VIRGIN AUSTRALIA AIRLINES PTY LTD
 Registered In New South Wales
 Registration Date 24/11/1999
 Review Date 27/05/2021
 Company Type ACN (Australian Company Number)
 Current Directors 2
 Current Secretaries 1

Start Date 20/04/2020
 Name VIRGIN AUSTRALIA AIRLINES PTY LTD
 Name Start Date 04/05/2011
 Status **** Under External Administration And/Or Controller Appointed ****
 Type Australian Proprietary Company
 Class Limited By Shares
 Sub Class Proprietary Company
 Disclosing Entity No
 Document No.

Share Structure (Displaying Top 4 Only)

[Go to Full ASIC Results](#)

Class	Class Type	Shares Issued	Amount Paid
ORD	ORDINARY SHARES	14195451	\$15,475,264.00

(creditor)watch - Credit Score (1)

[Go to Full Credit Report](#)



Risk Data Summary

Court Judgments 0 Payment Defaults 0 Insolvency Notices 3 Mercantile Enquiries 0 Credit Enquiries 409

REVEAL - Company Visualisation

[Go to full workspace](#)

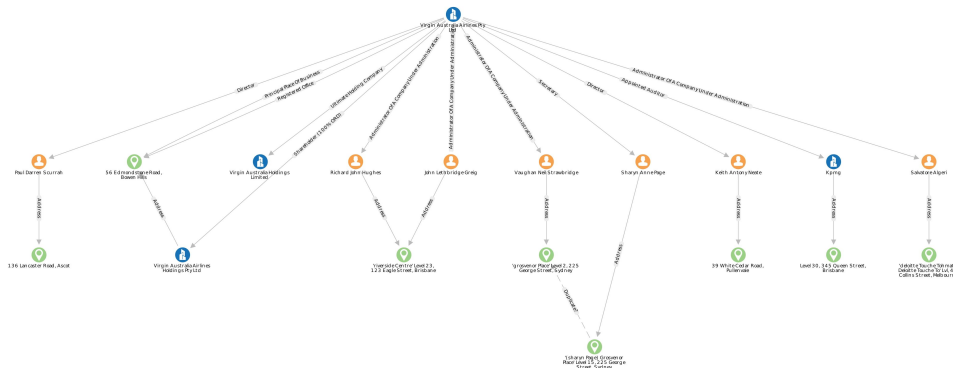

ASIC Data Extracted 22/06/2020 at 08:57

This extract contains information derived from the Australian Securities and Investment Commission's (ASIC) database under section 1274A of the Corporations Act 2001. Please advise ASIC of any error or omission which you may identify.

- 090 670 965 VIRGIN AUSTRALIA AIRLINES PTY LTD -

ACN (Australian Company Number):	090 670 965	Document No.
ABN:	36 090 670 965	
Current Name:	VIRGIN AUSTRALIA AIRLINES PTY LTD	
Registered in:	New South Wales	
Registration Date:	24/11/1999	
Review Date:	27/05/2021	
Company Bounded By:		

- Current Organisation Details -

Name: VIRGIN AUSTRALIA AIRLINES PTY LTD
Name Start Date: 04/05/2011
Status: ** Under External Administration And/Or Controller Appointed **
Type: Australian Proprietary Company
Class: Limited By Shares
Sub Class: Proprietary Company

- Company Addresses -

- Registered Office 1F0208910
Address: 56 EDMONDSTONE ROAD BOWEN HILLS QLD 4006
Start Date: 19/09/2008

- Principal Place of Business 1F0208910
Address: 56 EDMONDSTONE ROAD BOWEN HILLS QLD 4006
Start Date: 22/08/2008

- Company Officers -

Note:

A date or address shown as UNKNOWN has not been updated since ASIC took over the records in 1991. For details, order the appropriate historical state or territory documents, available in microfiche or paper format.

* Check documents listed under ASIC Documents Received for recent changes.

[Directors](#)

Name: PAUL DARREN SCURRAH 7EAJ95080
Address: 136 LANCASTER ROAD ASCOT QLD 4007
Birth Details: 03/01/1968 CHELSEA VIC
Appointment Date: 25/03/2019
Cease Date: //

Name: KEITH ANTONY NEATE 7EAQ31263
Address: 39 WHITE CEDAR ROAD PULLENVALE QLD 4069
Birth Details: 05/10/1961 LOWER KINGSWOOD UNITED KINGDOM
Appointment Date: 01/10/2019
Cease Date: //

Secretaries

Name: SHARYN ANNE PAGE 7E7704673
Address: '(SHARYN PAGE) GROSVENOR PLACE' LEVEL 15 225 GEORGE STREET
SYDNEY NSW 2000
Birth Details: 07/01/1963 WAGGA WAGGA NSW
Appointment Date: 01/02/2016
Cease Date: //

Appointed Auditors

Name: 024 510 530 KPMG 023387374
Address: LEVEL 30 345 QUEEN STREET BRISBANE QLD 4000 (FR 2006)
Appointment Date: 10/08/2006
Cease Date: //

Ultimate Holding Company

Name: 100 686 226 VIRGIN AUSTRALIA HOLDINGS LIMITED 09067096M
Address: (AR 2002)
Appointment Date: //
Cease Date: //
Abn: 54 100 686 226

Administrator of a Company under Administration

Name: RICHARD JOHN HUGHES 7EAV78252
Address: DELOITTE TOUCHE TOHMATSU 'RIVERSIDE CENTRE' LEVEL 23 123 EAGLE
STREET BRISBANE QLD 4000
Birth Details: //
Appointment Date: 20/04/2020
Cease Date: //

Name: JOHN LETHBRIDGE GREIG 7EAV78252
Address: DELOITTE TOUCHE TOHMATSU 'RIVERSIDE CENTRE' LEVEL 23 123 EAGLE STREET BRISBANE QLD 4000
Birth Details: //
Appointment Date: 20/04/2020
Cease Date: //

Name: VAUGHAN NEIL STRAWBRIDGE 7EAV78252
Address: C/- DELOITTE TOUCHE TOHMATSU 'GROSVENOR PLACE' LEVEL 2 225 GEORGE STREET SYDNEY NSW 2000
Birth Details: //
Appointment Date: 20/04/2020
Cease Date: //

Name: SALVATORE ALGERI 7EAW57466
Address: DELOITTE TOUCHE TOHMATSU 'DELOITTE TOUCHE TOHMATSU DELOITTE TOUCHE TO' LVL 477 COLLINS STREET MELBOURNE VIC 3000
Birth Details: //
Appointment Date: 20/04/2020
Cease Date: //

- Share Structure -

Current

Class: ORDINARY SHARES 019847118
Number of Shares Issued: 14195451
Total Amount Paid / Taken to be Paid: \$15,475,264.00
Total Amount Due and Payable: \$0.00

Note:

For each class of shares issued by a company, ASIC records the details of the twenty members of the class (based on shareholdings). The details of any other members holding the same number of shares as the twentieth ranked member will also be recorded by ASIC on the database. Where available, historical records show that a member has ceased to be ranked amongst the twenty members. This may, but does not necessarily mean, that they have ceased to be a member of the company.

- Share/Interest Holding -

Current

- Holding -

Class: ORD **Number Held:** 14195451 019847118
Beneficially Owned: Yes **Fully Paid:** Yes

- Members -

Name: VIRGIN AUSTRALIA AIRLINES HOLDINGS PTY LTD
ACN: 093 924 675
Address: 56 EDMONDSTONE ROAD BOWEN HILLS QLD 4006
Joint Holding: No
Abn: 19 093 924 675

- External Administration Documents -

Note:

Documents relating to External Administration and/or appointment of Controller.

This extract may not list all documents relating to this status. State and Territory records should be searched.

Form Type	Description	Date Lodged	Processed	No. Pages	Document No.
5011		20/06/2020	20/06/2020	38	7EAX68614
5011A	COPY OF MINUTES OF MEETING OF MEMBERS, CREDITORS, CONTRIBUTORIES OR COMMITTEE OF INSPECTION OTHER THAN UNDER S.436E OR S.439A				
506		18/05/2020	18/05/2020	4	7EAW57466
506L	NOTIFICATION OF CHANGE OF ADDRESS OF NOTIFICATION OF CHANGE OF ADDRESS OF AN EXTERNAL ADMINISTRATOR OR CONTROLLER OR SCHEME ADMINISTRATOR				
5011		11/05/2020	11/05/2020	56	7EAW38789
5011B	COPY OF MINUTES OF MEETING OF MEMBERS, CREDITORS, CONTRIBUTORIES OR COMMITTEE OF INSPECTION UNDER S.436E OR S.439A				
531		22/04/2020	22/04/2020	14	7EAV81862
531A	DECLARATION OF RELEVANT RELATIONSHIPS AND/OR INDEMNITY COPY OF A DIRRI				
505		21/04/2020	21/04/2020	3	7EAV78252
505U	NOTICE BY EXTERNAL ADMINISTRATOR/CONTROLLER-APPOINT/CEASE APPT OF ADMINISTRATOR UNDER S.436A, 436B, 436C, 436E(4), 449B, 449C(1), 449C(4) OR 449(6)				

- Charges -

There are no charges held for this organisation.

Notes:

On 30 January 2012, the Personal Property Securities Register (PPS Register) commenced.

At that time ASIC transferred all details of current charges to the PPS Registrar.

ASIC can only provide details of satisfied charges prior to that date.

Details of current charges, or charge satisfied since 30 January 2012 can be found on the PPS Register, www.ppsr.gov.au.

InfoTrack may cap documents for on-file searches to 250.

- Document List -

Notes:

- * Documents already listed under Registered Charges are not repeated here.
- * Data from Documents with no Date Processed are not included in this Extract.
- * Documents with '0' pages have not yet been imaged and are not available via DOCIMAGE. Imaging takes approximately 2 weeks from date of lodgement.
- * The document list for a current/historical extract will be limited unless you requested ALL documents for this extract.
- * In certain circumstances documents may be capped at 250.

Form Type	Date Received	Date Processed	No. Pages	Effective Date	Document No.
484 484E	15/10/2019	15/10/2019	2	15/10/2019	7EAQ31263
	Change to Company Details Appointment or Cessation of A Company Officeholder				
484 484E	29/03/2019	29/03/2019	2	29/03/2019	7EAJ95080
	Change to Company Details Appointment or Cessation of A Company Officeholder				
484 484E	25/11/2016	25/11/2016	2	25/11/2016	7E8562420
	Change to Company Details Appointment or Cessation of A Company Officeholder				
484 484E	16/02/2016	16/02/2016	2	16/02/2016	7E7704673
	Change to Company Details Appointment or Cessation of A Company Officeholder				
484 484E	01/10/2015	01/10/2015	2	01/10/2015	7E7350490
	Change to Company Details Appointment or Cessation of A Company Officeholder				
484 484A1 484E	31/10/2013	31/10/2013	3	31/10/2013	7E5618079
	Change to Company Details Change Officeholder Name or Address Appointment or Cessation of a Company Officeholder				
484 484A1	04/04/2013	04/04/2013	2	04/04/2013	7E5130421
	Change to Company Details Change Officeholder Name Or Address				
484 484A1	15/03/2013	15/03/2013	2	15/03/2013	7E5089257
	Change to Company Details Change Officeholder Name Or Address				
484 484A1	26/06/2012	26/06/2012	2	26/06/2012	7E4542418
	Change to Company Details Change Officeholder Name Or Address				
312 312C	25/01/2012	26/01/2012	2	25/01/2012	026016905
	Notification of Release of Property				
312 312C	25/01/2012	26/01/2012	2	25/01/2012	026016903
	Notification of Release of Property				

309	25/01/2012	26/01/2012	22	24/01/2012	026016898
309A	Notification of Details of a Charge				
309	24/01/2012	26/01/2012	27	23/01/2012	026016897
309A	Notification of Details of a Charge				
309	24/01/2012	26/01/2012	21	24/01/2012	026016890
309A	Notification of Details of a Charge				
309	23/12/2011	03/01/2012	21	21/12/2011	027189867
309A	Notification of Details of a Charge				
312	22/12/2011	10/01/2012	2	22/12/2011	026016839
312C	Notification of Release of Property				
312	22/12/2011	10/01/2012	2	22/12/2011	026016838
312C	Notification of Release of Property				
309	14/12/2011	16/12/2011	26	12/12/2011	027189790
309A	Notification of Details of a Charge				
309	05/12/2011	06/12/2011	21	22/11/2011	027189739
309A	Notification of Details of a Charge				
312	02/12/2011	05/12/2011	2	02/12/2011	027853764
312C	Notification of Release of Property				
312	02/12/2011	05/12/2011	2	02/12/2011	027853765
312C	Notification of Release of Property				
309	28/11/2011	29/11/2011	28	21/11/2011	026016789
309A	Notification of Details of a Charge				
309	28/11/2011	29/11/2011	24	23/11/2011	026016788
309A	Notification of Details of a Charge				
309	11/11/2011	14/11/2011	24	08/11/2011	026016775
309A	Notification of Details of a Charge				
309	18/10/2011	19/10/2011	25	14/10/2011	027189602
309A	Notification of Details of a Charge				
484	26/09/2011	26/09/2011	4	26/09/2011	027788400
484A1	Change to Company Details Change Officeholder Name Or Address				
309	07/09/2011	08/09/2011	28	06/09/2011	026016666
309A	Notification of Details of a Charge				
309	02/09/2011	05/09/2011	63	31/08/2011	027189460
309A	Notification of Details of a Charge				
309	01/08/2011	02/08/2011	65	28/07/2011	027189343
309A	Notification of Details of a Charge				

484 484E	18/07/2011	18/07/2011	4	18/07/2011	027540776
	Change to Company Details Appointment or Cessation of A Company Officeholder				
309 309A	21/06/2011	22/06/2011	38	20/06/2011	026016479
	Notification of Details of a Charge				
309 309A	17/06/2011	20/06/2011	25	08/06/2011	027189111
	Notification of Details of a Charge				
484 484A1	10/06/2011	10/06/2011	2	10/06/2011	7E3729843
	Change to Company Details Change Officeholder Name Or Address				
309 309A	24/05/2011	25/05/2011	28	23/05/2011	026016433
	Notification of Details of a Charge				
484 484E 484E	20/05/2011	20/05/2011	2	20/05/2011	7E3682130
	Change to Company Details Appointment or Cessation of A CHANGE TO COMPANY DETAILS APPOINTMENT OR CESSATION OF A COMPANY OFFICEHOLDER				
309 309A	16/05/2011	17/05/2011	28	12/05/2011	026016416
	NOTIFICATION OF DETAILS OF A CHARGE				
309 309A	12/05/2011	13/05/2011	28	10/05/2011	026016408
	NOTIFICATION OF DETAILS OF A CHARGE				
309 309A	04/05/2011	05/05/2011	27	18/04/2011	026016380
	NOTIFICATION OF DETAILS OF A CHARGE				
205 205A	04/05/2011	04/05/2011	3	29/04/2011	025132085
	NOTIFICATION OF RESOLUTION CHANGING COMPANY NAME				
309 309A	28/04/2011	29/04/2011	20	21/04/2011	026026977
	NOTIFICATION OF DETAILS OF A CHARGE				
488 488M	27/04/2011	18/05/2011	6	27/04/2011	026621238
	APPLICATION TO CHANGE REVIEW DATE OF A COMPANY OR SCHEME SYNCHRONISE REVIEW DATE WITH HOLDING COMPANY - NO FEE				
309 309A	27/04/2011	28/04/2011	24	18/04/2011	026016361
	NOTIFICATION OF DETAILS OF A CHARGE				
309 309A	01/04/2011	04/04/2011	23	31/03/2011	026016274
	NOTIFICATION OF DETAILS OF A CHARGE				
309 309A	31/03/2011	01/04/2011	27	25/03/2011	026016195
	NOTIFICATION OF DETAILS OF A CHARGE				
484 484A1	23/03/2011	23/03/2011	2	23/03/2011	7E3558913
	CHANGE TO COMPANY DETAILS CHANGE OFFICEHOLDER NAME OR ADDRESS				

309	15/03/2011	16/03/2011	27	11/03/2011	026026802
309A	NOTIFICATION OF DETAILS OF A CHARGE				
309	15/03/2011	16/03/2011	27	11/03/2011	026026796
309A	NOTIFICATION OF DETAILS OF A CHARGE				
484	11/03/2011	11/03/2011	3	11/03/2011	7E3531795
484E	CHANGE TO COMPANY DETAILS APPOINTMENT OR CESSATION OF A COMPANY OFFICEHOLDER				
309	09/03/2011	10/03/2011	24	03/03/2011	026016166
309A	NOTIFICATION OF DETAILS OF A CHARGE				
484	17/01/2011	17/01/2011	3	17/01/2011	7E3416919
484E	CHANGE TO COMPANY DETAILS APPOINTMENT OR CESSATION OF A COMPANY OFFICEHOLDER				
309	07/01/2011	10/01/2011	36	23/12/2010	027412855
309A	NOTIFICATION OF DETAILS OF A CHARGE				
309	07/01/2011	10/01/2011	23	23/12/2010	027412854
309A	NOTIFICATION OF DETAILS OF A CHARGE				
309	16/12/2010	17/12/2010	21	16/12/2010	024988990
309A	NOTIFICATION OF DETAILS OF A CHARGE				
484	26/11/2010	26/11/2010	2	26/11/2010	7E3323851
484E	CHANGE TO COMPANY DETAILS APPOINTMENT OR CESSATION OF A COMPANY OFFICEHOLDER				
309	05/10/2010	06/10/2010	21	29/09/2010	026026165
309A	NOTIFICATION OF DETAILS OF A CHARGE				
309	20/09/2010	20/09/2010	21	15/09/2010	024191662
309A	NOTIFICATION OF DETAILS OF A CHARGE				
312	16/09/2010	//	0	16/09/2010	027099828
312A	NOTIFICATION OF DISCHARGE				
484	09/09/2010	09/09/2010	2	09/09/2010	7E3160815
484E	CHANGE TO COMPANY DETAILS APPOINTMENT OR CESSATION OF A COMPANY OFFICEHOLDER				
309	03/08/2010	04/08/2010	20	30/07/2010	024979956
309A	NOTIFICATION OF DETAILS OF A CHARGE				
309	01/06/2010	02/06/2010	20	28/05/2010	024979323
309A	NOTIFICATION OF DETAILS OF A CHARGE				
484	13/05/2010	13/05/2010	3	13/05/2010	7E2888679
484E	CHANGE TO COMPANY DETAILS APPOINTMENT OR CESSATION OF A COMPANY OFFICEHOLDER				

309	29/04/2010	30/04/2010	65	19/04/2010	024979233
309A	NOTIFICATION OF DETAILS OF A CHARGE				
484	26/03/2010	26/03/2010	2	26/03/2010	7E2793139
484E	CHANGE TO COMPANY DETAILS APPOINTMENT OR CESSATION OF A COMPANY OFFICEHOLDER				
484	28/01/2010	28/01/2010	2	28/01/2010	7E2675836
484E	CHANGE TO COMPANY DETAILS APPOINTMENT OR CESSATION OF A COMPANY OFFICEHOLDER				
309	07/01/2010	08/01/2010	22	21/12/2009	024988305
309A	NOTIFICATION OF DETAILS OF A CHARGE				
309	20/11/2009	23/11/2009	34	05/11/2009	024988157
309A	NOTIFICATION OF DETAILS OF A CHARGE				
309	09/11/2009	10/11/2009	18	06/11/2009	024988107
309A	NOTIFICATION OF DETAILS OF A CHARGE				
484	04/11/2009	04/11/2009	2	04/11/2009	7E2524826
484E	CHANGE TO COMPANY DETAILS APPOINTMENT OR CESSATION OF A COMPANY OFFICEHOLDER				
309	29/10/2009	30/10/2009	22	28/10/2009	024191360
309A	NOTIFICATION OF DETAILS OF A CHARGE				
309	17/09/2009	18/09/2009	34	16/09/2009	024988033
309A	NOTIFICATION OF DETAILS OF A CHARGE				
484	04/06/2009	04/06/2009	2	04/06/2009	7E2224469
484A1	CHANGE TO COMPANY DETAILS CHANGE OFFICEHOLDER NAME OR ADDRESS				
311	29/05/2009	01/06/2009	6	30/04/2009	024098611
311B	NOTIFICATION OF CHANGE TO DETAILS OF CHARGE				
311	29/05/2009	01/06/2009	6	30/04/2009	024098612
311B	NOTIFICATION OF CHANGE TO DETAILS OF CHARGE				
309	29/04/2009	30/04/2009	34	22/04/2009	025577222
309A	NOTIFICATION OF DETAILS OF A CHARGE				
309	29/04/2009	30/04/2009	33	22/04/2009	025577223
309A	NOTIFICATION OF DETAILS OF A CHARGE				
311	21/04/2009	21/04/2009	5	31/03/2009	024098484
311B	NOTIFICATION OF CHANGE TO DETAILS OF CHARGE				
311	21/04/2009	21/04/2009	5	31/03/2009	024098483
311B	NOTIFICATION OF CHANGE TO DETAILS OF CHARGE				
309	16/04/2009	17/04/2009	24	20/03/2009	025506600
309A	NOTIFICATION OF DETAILS OF A CHARGE				

484 484E	09/04/2009	09/04/2009	2	09/04/2009	7E2130133
	CHANGE TO COMPANY DETAILS APPOINTMENT OR CESSATION OF A COMPANY OFFICEHOLDER				
350 350	24/03/2009	25/03/2009	2	24/03/2009	025476625
	CERTIFICATION OF COMPLIANCE WITH STAMP DUTIES LAW BY PROVISIONAL CHARGE Alters 024 191 126				
309 309A	02/03/2009	03/03/2009	26	27/02/2009	024191258
	NOTIFICATION OF DETAILS OF A CHARGE				
309 309A	02/03/2009	03/03/2009	33	27/02/2009	024191260
	NOTIFICATION OF DETAILS OF A CHARGE				
309 309A	27/02/2009	02/03/2009	150	16/01/2009	024098271
	NOTIFICATION OF DETAILS OF A CHARGE				
311 311B	26/02/2009	27/02/2009	85	16/01/2009	024098258
	NOTIFICATION OF CHANGE TO DETAILS OF CHARGE				
309 309A	12/01/2009	13/01/2009	32	23/12/2008	024191126
	NOTIFICATION OF DETAILS OF A CHARGE Altered by 025 476 625				
309 309A	12/01/2009	13/01/2009	33	23/12/2008	024191125
	NOTIFICATION OF DETAILS OF A CHARGE				
484 484E	02/01/2009	02/01/2009	3	02/01/2009	7E1969845
	CHANGE TO COMPANY DETAILS APPOINTMENT OR CESSATION OF A COMPANY OFFICEHOLDER				
309 309A	18/12/2008	19/12/2008	30	12/12/2008	025360127
	NOTIFICATION OF DETAILS OF A CHARGE				
309 309A	03/11/2008	04/11/2008	39	27/10/2008	025164582
	NOTIFICATION OF DETAILS OF A CHARGE				
309 309A	31/10/2008	03/11/2008	30	30/10/2008	024566887
	NOTIFICATION OF DETAILS OF A CHARGE				
309 309A	23/10/2008	24/10/2008	60	20/01/2008	023212973
	NOTIFICATION OF DETAILS OF A CHARGE				
309 309A	02/10/2008	03/10/2008	30	27/09/2008	025033839
	NOTIFICATION OF DETAILS OF A CHARGE				
309 309A	26/09/2008	29/09/2008	30	20/09/2008	024857184
	NOTIFICATION OF DETAILS OF A CHARGE				
484 484 484B	12/09/2008	12/09/2008	4	12/09/2008	1F0208910
	CHANGE TO COMPANY DETAILS CHANGE OF REGISTERED ADDRESS				

484C	CHANGE OF PRINCIPAL PLACE OF BUSINESS (ADDRESS)				
484A2	CHANGE MEMBER NAME OR ADDRESS				
484E	APPOINTMENT OR CESSATION OF A COMPANY OFFICEHOLDER				
309	08/09/2008	09/09/2008	30	06/09/2008	025022976
309A	NOTIFICATION OF DETAILS OF A CHARGE				
309	29/08/2008	01/09/2008	30	29/08/2008	024918216
309A	NOTIFICATION OF DETAILS OF A CHARGE				
309	13/08/2008	13/08/2008	30	13/08/2008	024559926
309A	NOTIFICATION OF DETAILS OF A CHARGE				
309	01/08/2008	01/08/2008	30	01/08/2008	024571000
309A	NOTIFICATION OF DETAILS OF A CHARGE				
309	01/08/2008	01/08/2008	39	01/08/2008	024570999
309A	NOTIFICATION OF DETAILS OF A CHARGE				
309	01/07/2008	01/07/2008	30	28/06/2008	024564372
309A	NOTIFICATION OF DETAILS OF A CHARGE				
309	01/07/2008	01/07/2008	30	28/06/2008	024564373
309A	NOTIFICATION OF DETAILS OF A CHARGE				
309	16/06/2008	16/06/2008	30	14/06/2008	024586886
309A	NOTIFICATION OF DETAILS OF A CHARGE				
309	11/06/2008	11/06/2008	34	09/06/2008	024570491
309A	NOTIFICATION OF DETAILS OF A CHARGE				
309	28/05/2008	28/05/2008	30	28/05/2008	024583536
309A	NOTIFICATION OF DETAILS OF A CHARGE				
309	07/05/2008	07/05/2008	30	07/05/2008	024577926
309A	NOTIFICATION OF DETAILS OF A CHARGE				
309	31/03/2008	31/03/2008	30	29/03/2008	024584188
309A	NOTIFICATION OF DETAILS OF A CHARGE				
309	13/03/2008	13/03/2008	30	08/03/2008	022894806
309A	NOTIFICATION OF DETAILS OF A CHARGE				
309	13/03/2008	13/03/2008	30	04/03/2008	022894804
309A	NOTIFICATION OF DETAILS OF A CHARGE				
350	16/11/2007	16/11/2007	2	16/11/2007	024179981
350	CERTIFICATION OF COMPLIANCE WITH STAMP DUTIES LAW BY PROVISIONAL CHARGE Alters 024 205 933				
309	15/11/2007	15/11/2007	29	01/11/2007	024205933
309A	NOTIFICATION OF DETAILS OF A CHARGE Altered by 024 179 981				

309	09/11/2007	09/11/2007	39	08/11/2007	024205671
309A	NOTIFICATION OF DETAILS OF A CHARGE				
389	29/10/2007	02/11/2007	3	30/06/2007	024153749
389B	ANNUAL NOTICE BY WHOLLY-OWNED ENTITY ANNUAL NOTICE BY WHOLLY-OWNED ENTITY - COMPANIES				
309	17/10/2007	17/10/2007	30	15/10/2007	023979680
309A	NOTIFICATION OF DETAILS OF A CHARGE				
309	04/09/2007	04/09/2007	30	01/09/2007	023975627
309A	NOTIFICATION OF DETAILS OF A CHARGE				
309	28/08/2007	28/08/2007	30	25/08/2007	022559849
309A	NOTIFICATION OF DETAILS OF A CHARGE				
309	20/08/2007	20/08/2007	30	16/08/2007	023965040
309A	NOTIFICATION OF DETAILS OF A CHARGE				
351	27/06/2007	28/06/2007	26	27/06/2007	023749657
351	DEED RELATING TO CLASS ORDER				
388	31/10/2006	10/11/2006	96	30/09/2006	023387374
388	FINANCIAL REPORT				
388E	COMPANY - APPOINT CHANGE NAME/ADDRESS OF AUDITOR				
388H	FINANCIAL REPORT - LARGE PROPRIETARY COMPANY THAT IS NOT A DISCLOSING ENTITY				
309	03/10/2006	03/10/2006	28	27/09/2006	022917926
309A	NOTIFICATION OF DETAILS OF A CHARGE				
312	17/08/2006	17/08/2006	1	17/08/2006	022937336
312C	NOTIFICATION OF RELEASE OF PROPERTY				
309	17/08/2006	17/08/2006	28	11/08/2006	022937337
309A	NOTIFICATION OF DETAILS OF A CHARGE				
312	03/08/2006	03/08/2006	1	03/08/2006	022559299
312C	NOTIFICATION OF RELEASE OF PROPERTY				
309	03/08/2006	03/08/2006	28	31/07/2006	022559298
309A	NOTIFICATION OF DETAILS OF A CHARGE				
315	28/07/2006	03/08/2006	1	25/07/2006	022971920
315A	NOTICE OF RESIGNATION OR REMOVAL OF AUDITOR RESIGNATION OF AUDITOR				
309	30/05/2006	30/05/2006	27	25/05/2006	022559105
309A	NOTIFICATION OF DETAILS OF A CHARGE				
312	30/05/2006	30/05/2006	1	30/05/2006	022559106
312C	NOTIFICATION OF RELEASE OF PROPERTY				

484	12/05/2006	12/05/2006	2	12/05/2006	7E0705137
484E	CHANGE TO COMPANY DETAILS APPOINTMENT OR CESSATION OF A COMPANY OFFICEHOLDER				
484	01/03/2006	01/03/2006	2	01/03/2006	7E0632062
484	CHANGE TO COMPANY DETAILS				
484B	CHANGE OF REGISTERED ADDRESS				
484A2	CHANGE MEMBER NAME OR ADDRESS				
388	31/01/2006	20/02/2006	56	30/09/2005	022663435
388	FINANCIAL REPORT				
388E	COMPANY - APPOINT CHANGE NAME/ADDRESS OF AUDITOR				
388H	FINANCIAL REPORT - LARGE PROPRIETARY COMPANY THAT IS NOT A DISCLOSING ENTITY				
315	28/09/2005	03/10/2005	1	19/09/2005	022376027
315A	NOTICE OF RESIGNATION OR REMOVAL OF AUDITOR RESIGNATION OF AUDITOR				
312	26/09/2005	26/09/2005	1	26/09/2005	021368723
312C	NOTIFICATION OF RELEASE OF PROPERTY				
484	23/09/2005	23/09/2005	2	23/09/2005	7E0495859
484A2	CHANGE TO COMPANY DETAILS CHANGE MEMBER NAME OR ADDRESS				
484	04/08/2005	14/09/2005	3	08/08/2005	021658787
484B	CHANGE TO COMPANY DETAILS CHANGE OF REGISTERED ADDRESS				
312	29/07/2005	29/07/2005	1	29/07/2005	021207668
312C	NOTIFICATION OF RELEASE OF PROPERTY				
309	05/05/2005	05/05/2005	18	27/04/2005	020767646
309A	NOTIFICATION OF DETAILS OF A CHARGE				
309	20/04/2005	20/04/2005	18	30/03/2005	020767593
309A	NOTIFICATION OF DETAILS OF A CHARGE				
309	21/12/2004	21/12/2004	18	16/12/2004	020115246
309A	NOTIFICATION OF DETAILS OF A CHARGE				
309	05/11/2004	05/11/2004	19	29/10/2004	020767092
309A	NOTIFICATION OF DETAILS OF A CHARGE				
309	20/10/2004	20/10/2004	19	08/10/2004	020767043
309A	NOTIFICATION OF DETAILS OF A CHARGE				
312	20/10/2004	20/10/2004	1	20/10/2004	020767042
312C	NOTIFICATION OF RELEASE OF PROPERTY				
309	23/09/2004	23/09/2004	19	17/09/2004	018675842
309A	NOTIFICATION OF DETAILS OF A CHARGE				
312	23/09/2004	23/09/2004	1	23/09/2004	018675856
312C	NOTIFICATION OF RELEASE OF PROPERTY				

309	02/09/2004	02/09/2004	19	25/08/2004	020156997
309A	NOTIFICATION OF DETAILS OF A CHARGE				
312	01/09/2004	01/09/2004	1	01/09/2004	020133971
312C	NOTIFICATION OF RELEASE OF PROPERTY				
312	26/08/2004	26/08/2004	1	26/08/2004	020124400
312C	NOTIFICATION OF RELEASE OF PROPERTY				
309	25/08/2004	25/08/2004	24	16/08/2004	020162137
309A	NOTIFICATION OF DETAILS OF A CHARGE				
309	25/08/2004	25/08/2004	19	12/08/2004	020162138
309A	NOTIFICATION OF DETAILS OF A CHARGE				
309	25/08/2004	25/08/2004	67	12/08/2004	020162143
309A	NOTIFICATION OF DETAILS OF A CHARGE				
309	23/08/2004	23/08/2004	21	12/08/2004	018987202
309A	NOTIFICATION OF DETAILS OF A CHARGE				
309	23/08/2004	23/08/2004	15	12/08/2004	018987203
309A	NOTIFICATION OF DETAILS OF A CHARGE				
388	30/07/2004	05/08/2004	47	31/03/2004	020527733
388H	FINANCIAL REPORT FINANCIAL REPORT - LARGE PROPRIETARY COMPANY THAT IS NOT A DISCLOSING ENTITY				
309	09/06/2004	09/06/2004	18	26/05/2004	020150285
309A	NOTIFICATION OF DETAILS OF A CHARGE				
309	28/05/2004	28/05/2004	19	19/05/2004	020144068
309A	NOTIFICATION OF DETAILS OF A CHARGE				
312	24/05/2004	24/05/2004	1	24/05/2004	020148774
312C	NOTIFICATION OF RELEASE OF PROPERTY				
312	06/05/2004	06/05/2004	1	06/05/2004	018996203
312C	NOTIFICATION OF RELEASE OF PROPERTY				
309	14/04/2004	14/04/2004	19	10/03/2004	018977669
309A	NOTIFICATION OF DETAILS OF A CHARGE				
309	12/03/2004	12/03/2004	15	26/02/2004	019999395
309A	NOTIFICATION OF DETAILS OF A CHARGE				
309	22/01/2004	22/01/2004	23	21/01/2004	019673826
309A	NOTIFICATION OF DETAILS OF A CHARGE				
309	18/12/2003	18/12/2003	18	16/12/2003	018975701
309A	NOTIFICATION OF DETAILS OF A CHARGE				
484	24/11/2003	27/11/2003	9	27/10/2003	019847118

484						
484N						
484J						
484O						
484	06/11/2003	07/11/2003	8	04/11/2003		019688196
484E					CHANGE TO COMPANY DETAILS APPOINTMENT OR CESSATION OF A COMPANY OFFICEHOLDER	
484	29/10/2003	30/10/2003	6	27/10/2003		017909985
484E					CHANGE TO COMPANY DETAILS APPOINTMENT OR CESSATION OF A COMPANY OFFICEHOLDER	
280	24/10/2003	05/11/2003	10	24/10/2003		019789409
280					NOTICE OF MEETING AND DOCUMENTS RE BUY-BACK	
309	21/10/2003	21/10/2003	17	08/10/2003		019000170
309A					NOTIFICATION OF DETAILS OF A CHARGE	
309	21/10/2003	21/10/2003	18	08/10/2003		019000169
309A					NOTIFICATION OF DETAILS OF A CHARGE	
312	21/10/2003	21/10/2003	1	21/10/2003		019000168
312C					NOTIFICATION OF RELEASE OF PROPERTY	
312	14/10/2003	14/10/2003	1	14/10/2003		018998577
312C					NOTIFICATION OF RELEASE OF PROPERTY	
281	10/10/2003	03/11/2003	2	10/10/2003		019460745
281					NOTICE THAT COMPANY INTENDS TO CARRY OUT BUY-BACK	
281	10/10/2003	03/11/2003	2	10/10/2003		019460743
281					NOTICE THAT COMPANY INTENDS TO CARRY OUT BUY-BACK	
309	02/10/2003	02/10/2003	16	30/09/2003		018988933
309A					NOTIFICATION OF DETAILS OF A CHARGE	
309	02/10/2003	02/10/2003	16	30/09/2003		018988929
309A					NOTIFICATION OF DETAILS OF A CHARGE	
309	02/10/2003	02/10/2003	26	30/09/2003		018988931
309A					NOTIFICATION OF DETAILS OF A CHARGE	
309	30/09/2003	30/09/2003	19	15/09/2003		019003969
309A					NOTIFICATION OF DETAILS OF A CHARGE	
309	30/09/2003	30/09/2003	19	11/09/2003		019003967
309A					NOTIFICATION OF DETAILS OF A CHARGE	
309	30/09/2003	30/09/2003	19	12/09/2003		019003965
309A					NOTIFICATION OF DETAILS OF A CHARGE	
388	24/09/2003	03/10/2003	36	28/03/2003		019640625
388H					FINANCIAL REPORT FINANCIAL REPORT - LARGE PROPRIETARY	

COMPANY THAT IS NOT A DISCLOSING ENTITY

312 312C	17/09/2003	17/09/2003	1	17/09/2003	018991003
	NOTIFICATION OF RELEASE OF PROPERTY				
312 312C	17/09/2003	17/09/2003	1	17/09/2003	018991002
	NOTIFICATION OF RELEASE OF PROPERTY				
312 312C	16/09/2003	16/09/2003	1	16/09/2003	018992927
	NOTIFICATION OF RELEASE OF PROPERTY				
312 312C	29/08/2003	29/08/2003	1	29/08/2003	018978618
	NOTIFICATION OF RELEASE OF PROPERTY				
309 309A	27/08/2003	27/08/2003	18	19/08/2003	018962937
	NOTIFICATION OF DETAILS OF A CHARGE				
312 312C	25/08/2003	//	0	25/08/2003	018962835
	NOTIFICATION OF RELEASE OF PROPERTY				
309 309A	20/08/2003	20/08/2003	19	11/08/2003	018666730
	NOTIFICATION OF DETAILS OF A CHARGE				
309 309A	20/08/2003	20/08/2003	69	12/08/2003	018666727
	NOTIFICATION OF DETAILS OF A CHARGE				
312 312C	20/08/2003	20/08/2003	1	20/08/2003	018666722
	NOTIFICATION OF RELEASE OF PROPERTY				
309 309A	19/08/2003	19/08/2003	13	12/08/2003	018666656
	NOTIFICATION OF DETAILS OF A CHARGE				
309 309A	19/08/2003	19/08/2003	12	12/08/2003	018666655
	NOTIFICATION OF DETAILS OF A CHARGE				
316 316L	31/01/2003	06/02/2003	4	31/01/2003	09067096M
	ANNUAL RETURN - PROPRIETARY COMPANY				
309 309A	15/01/2003	15/01/2003	29	13/01/2003	018692783
	NOTIFICATION OF DETAILS OF A CHARGE				
388 388H	19/12/2002	07/01/2003	35	28/03/2002	018620777
	FINANCIAL REPORT FINANCIAL REPORT - LARGE PROPRIETARY COMPANY THAT IS NOT A DISCLOSING ENTITY				
304 304A	12/12/2002	12/12/2002	2	01/12/2002	017895507
	NOTIFICATION OF CHANGE TO OFFICEHOLDERS OF AUSTRALIAN COMPANY				
304 304A	13/06/2002	18/06/2002	3	30/05/2002	018118863
	NOTIFICATION OF CHANGE TO OFFICEHOLDERS OF AUSTRALIAN COMPANY				
284	14/05/2002	24/05/2002	1	02/05/2002	018127922

284C						
280	17/04/2002	06/05/2002	39	17/04/2002		017829117
280						
316	04/02/2002	26/11/2002	3	31/01/2002		09067096L
316L						
902	30/01/2002	08/02/2002	1	20/12/2001		017095998
902						
304	28/12/2001	28/12/2001	2	20/12/2001		017935320
304A						
388	27/11/2001	10/12/2001	30	31/03/2001		017723871
388						
388E						
388H						
909	11/07/2001	17/07/2001	1	06/07/2001		017302771
909						
316	31/01/2001	04/06/2001	3	30/01/2001		09067096K
316L						
304	03/11/2000	07/11/2000	2	21/09/2000		016603395
304A						
207	03/11/2000	03/11/2000	1	21/09/2000		016603393
207						
205	03/11/2000	03/11/2000	1	30/10/2000		016603391
205A						
410	31/10/2000	31/10/2000	2	31/10/2000		015772506
410B						
410	28/08/2000	28/08/2000	2	28/08/2000		015218993
410B						
909	26/07/2000	31/07/2000	1	21/07/2000		016477232
909						
316	25/07/2000	24/10/2000	3	21/07/2000		09067096J
316						
316A						

316T	CHANGE TO PRINCIPAL PLACE OF BUSINESS				
316L	ANNUAL RETURN - PROPRIETARY COMPANY				
304	20/04/2000	19/09/2000	2	14/04/2000	014685650
304	NOTIFICATION OF				
304A	CHANGE TO OFFICEHOLDERS OF AUSTRALIAN COMPANY				
304C	CHANGE OF NAME OR ADDRESS OF OFFICEHOLDER				
201	24/11/1999	24/11/1999	3	24/11/1999	0E3743310
201C	APPLICATION FOR REGISTRATION AS A PROPRIETARY COMPANY				

- Financial Reports -

Document No.	Balance Date	Report Due	AGM Due	Extended AGM Due	AGM Held	Outstanding
017723871	31/03/2001	31/07/2001	//	//	//	No
018620777	28/03/2002	28/07/2002	//	//	//	No
019640625	28/03/2003	28/07/2003	//	//	//	No
020527733	31/03/2004	31/07/2004	//	//	//	No
022663435	30/09/2005	28/02/2006	//	//	//	No
023387374	30/09/2006	28/02/2007	//	//	//	No

- Company Contact Addresses -

- Contact Address for ASIC use only

Address: LEVEL 5 7-15 MACQUARIE PLACE SYDNEY NSW 2000
Start Date: 26/09/2011

*** End of Document ***

Risk Data

Summary

Organisation Status:	Under External Administration And/Or Controller Appointed
Court Actions:	0
Payment Defaults:	0
ASIC Published Notices:	3
Mercantile Enquiries:	0
Critical ASIC Documents:	5
Credit Score:	1
Credit Enquiries - Last 5 Years:	409
Credit Enquiries - Last 12 Months:	197

Status Changes

ASIC Entity Status Changes

Change Date	ASIC Changes
20-04-2020	Under External Administration And/Or Controller Appointed (Current status)
24-11-1999	Registered

Credit Report

Court Actions

Plaintiff	Action	Action Amount	Action Date	Nature of claim	Proceeding #	Location
-----------	--------	---------------	-------------	-----------------	--------------	----------

There are currently no court actions registered.

Court action information is supplied to CreditorWatch by the courts. We rely on the courts to provide up to date and accurate information and therefore CreditorWatch cannot guarantee that all actions are included. This report includes action information from the Magistrates courts in NSW, QLD, SA, VIC, and WA.

Payment Defaults

Default Posted By	Document Type	Amount Outstanding	Date Added	Payment Due Date	Part Payment Made	Default Settled
-------------------	---------------	--------------------	------------	------------------	-------------------	-----------------

There are currently no defaults registered.

ASIC Published Notices

Date	Title
04-06-2020	NOTICE OF MEETING OF MEMBERS OF COMMITTEE OF INSPECTION

Date	Title
18-05-2020	NOTICE OF MEETING OF MEMBERS OF COMMITTEE OF INSPECTION
21-04-2020	COMBINED NOTICE OF APPOINTMENT AND FIRST MEETING OF CREDITORS OF COMPANY UNDER ADMINISTRATION

Registered Mercantile Enquiries

Enquiry Date	Mercantile Agent
--------------	------------------

There are no mercantile enquiries registered.

Credit Score

The score is a statistically based score indicating an entity's credit worthiness. The score ultimately ranks entities based on their riskiness and is designed to assist you in making more informed and consistent credit decisions.

The score is based between 0 and 850 index points with a higher score considered lower risk while lower scores are deemed to be riskier entities. It should be used in partnership with your internal credit procedures and policies.

Entity has a critical status and significant adverse information present. Trading eligibility must be considered.

1



Historical Credit Scores

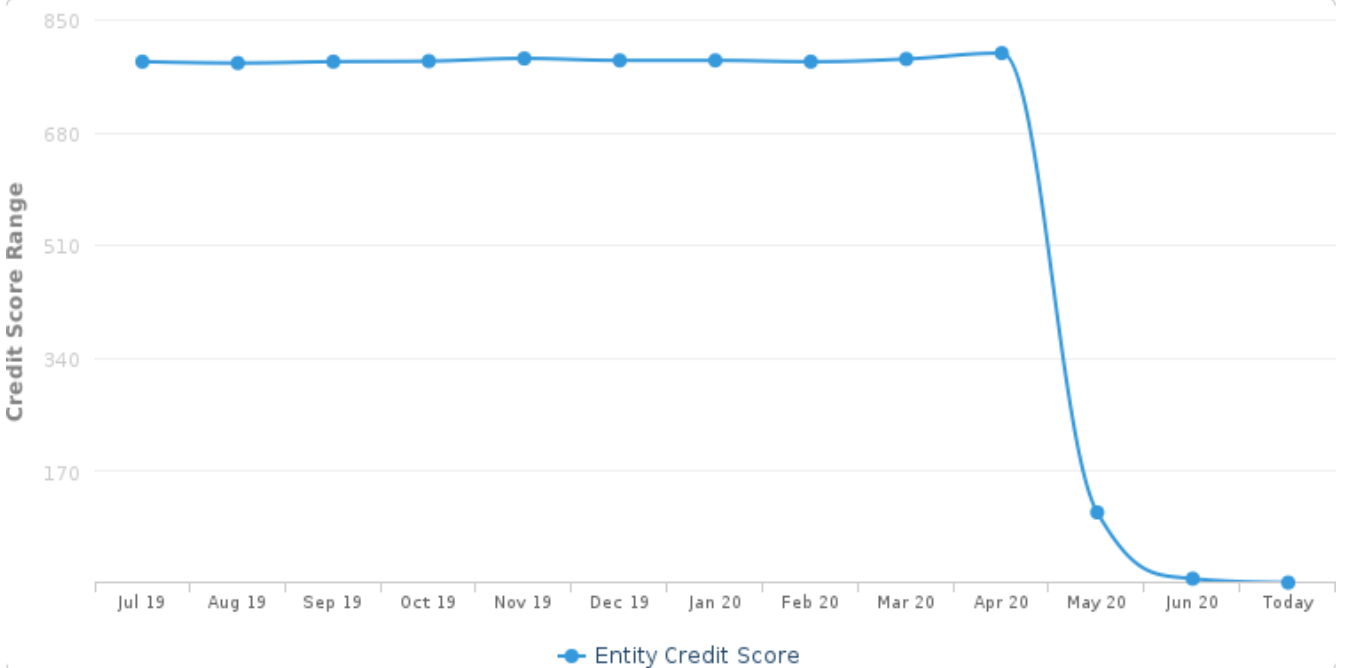

Recommendations

Range	Risk level	Recommendation
0	Critical	ACN deregistered or ABN cancelled.
1 - 125	Critical	Entity has a critical status and significant adverse information present. Trading eligibility must be considered.
126 - 250	Very High	Entity has multiple pieces of adverse information present. COD trading highly recommended.
251 - 450	High	Entity has a below average creditworthiness score and some adverse information may be present. Trade with caution, monitor closely and consider your payment terms.
451 - 550	Moderate	Entity has moderate creditworthiness with or without adverse information. Monitor ongoing payment behaviour.
551 - 850	Low	Entity has acceptable creditworthiness. Extend terms within consideration.

score v.20150123a

Please note that the score and recommendation should be used in partnership with your company's internal credit procedures and policies. The score should not be used as the sole reason in making a decision about the entity.

Credit Enquiries

Entity has 409 credit enquiries within the last 5 years.
Entity has 197 credit enquiries within the last 12 months.

Credit Enquiries (Last 12 Months)

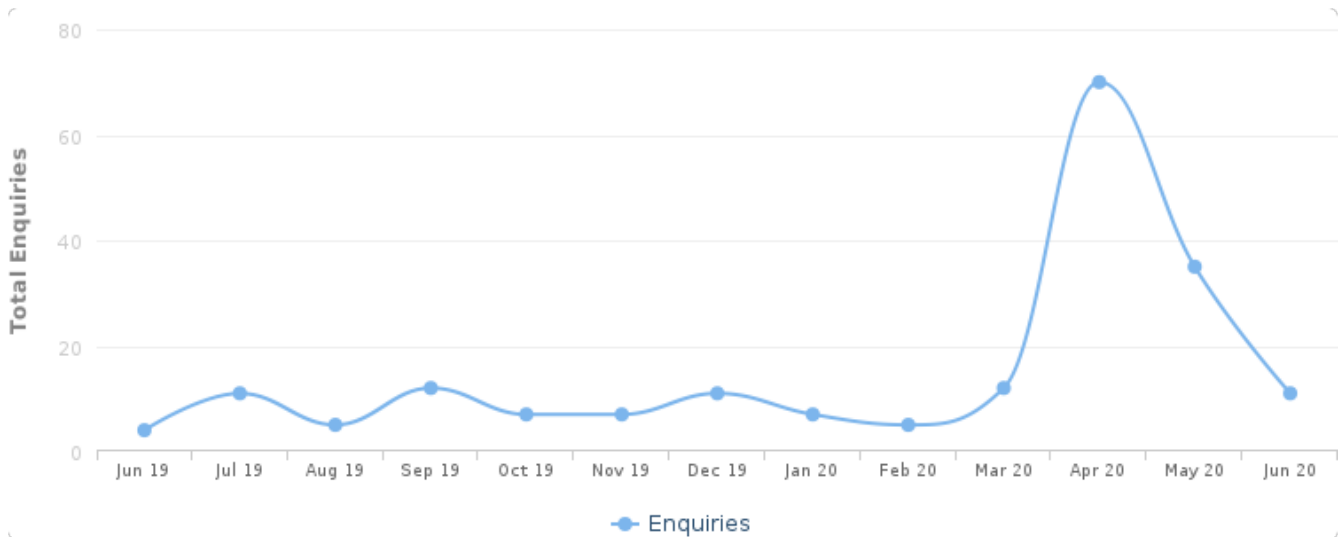

Ordered by Industry (Last 12 Months)

Industry	Number of Enquiries
Professional, Scientific and Technical Services (M)	64
Construction (E)	30
Other Services (S)	17
Wholesale Trade (F)	16
Financial and Insurance Services (K)	13
Retail Trade (G)	10
Information Media and Telecommunications (J)	10
Transport, Postal and Warehousing (I)	9
Electricity, Gas, Water and Waste Services (D)	8
Manufacturing (C)	8
Mining (B)	6
Health Care and Social Assistance (Q)	2
Education and Training (P)	2
N/A	1
Accommodation and Food Services (H)	1
TOTAL ENQUIRIES	197

Ordered by Date (Last 12 Months)

Industry	Date
Professional, Scientific and Technical Services (M)	22-06-2020
Mining (B)	19-06-2020
Retail Trade (G)	18-06-2020
Electricity, Gas, Water and Waste Services (D)	15-06-2020
Information Media and Telecommunications (J)	09-06-2020
Wholesale Trade (F)	09-06-2020
Financial and Insurance Services (K)	04-06-2020
Financial and Insurance Services (K)	03-06-2020
Financial and Insurance Services (K)	02-06-2020
Construction (E)	02-06-2020
Construction (E)	01-06-2020
Professional, Scientific and Technical Services (M)	29-05-2020
Information Media and Telecommunications (J)	29-05-2020
Professional, Scientific and Technical Services (M)	28-05-2020
Financial and Insurance Services (K)	27-05-2020
Manufacturing (C)	22-05-2020
Wholesale Trade (F)	22-05-2020
Construction (E)	21-05-2020
Retail Trade (G)	21-05-2020
Other Services (S)	20-05-2020
Construction (E)	20-05-2020
Financial and Insurance Services (K)	19-05-2020
Construction (E)	19-05-2020
Other Services (S)	19-05-2020
Financial and Insurance Services (K)	18-05-2020
Electricity, Gas, Water and Waste Services (D)	15-05-2020
Professional, Scientific and Technical Services (M)	14-05-2020
Retail Trade (G)	13-05-2020
Construction (E)	12-05-2020
Construction (E)	12-05-2020
Wholesale Trade (F)	12-05-2020
Mining (B)	12-05-2020
Information Media and Telecommunications (J)	11-05-2020
Professional, Scientific and Technical Services (M)	08-05-2020
Professional, Scientific and Technical Services (M)	07-05-2020
Financial and Insurance Services (K)	06-05-2020
Professional, Scientific and Technical Services (M)	06-05-2020
Information Media and Telecommunications (J)	04-05-2020
Construction (E)	04-05-2020
Professional, Scientific and Technical Services (M)	04-05-2020
Other Services (S)	03-05-2020

Industry	Date
Professional, Scientific and Technical Services (M)	01-05-2020
Construction (E)	01-05-2020
Financial and Insurance Services (K)	01-05-2020
Electricity, Gas, Water and Waste Services (D)	01-05-2020
Mining (B)	01-05-2020
Education and Training (P)	30-04-2020
Electricity, Gas, Water and Waste Services (D)	30-04-2020
Health Care and Social Assistance (Q)	30-04-2020
Electricity, Gas, Water and Waste Services (D)	29-04-2020
Wholesale Trade (F)	29-04-2020
Mining (B)	28-04-2020
Professional, Scientific and Technical Services (M)	27-04-2020
Construction (E)	27-04-2020
Wholesale Trade (F)	26-04-2020
Construction (E)	24-04-2020
Other Services (S)	24-04-2020
Construction (E)	24-04-2020
Construction (E)	23-04-2020
Manufacturing (C)	23-04-2020
Construction (E)	23-04-2020
Information Media and Telecommunications (J)	23-04-2020
Other Services (S)	23-04-2020
Other Services (S)	22-04-2020
Transport, Postal and Warehousing (I)	22-04-2020
Other Services (S)	22-04-2020
Other Services (S)	22-04-2020
Financial and Insurance Services (K)	22-04-2020
Manufacturing (C)	22-04-2020
Wholesale Trade (F)	22-04-2020
Manufacturing (C)	22-04-2020
Wholesale Trade (F)	22-04-2020
Professional, Scientific and Technical Services (M)	22-04-2020
Electricity, Gas, Water and Waste Services (D)	22-04-2020
Construction (E)	22-04-2020
Construction (E)	22-04-2020
Other Services (S)	22-04-2020
Other Services (S)	21-04-2020
Construction (E)	21-04-2020
Construction (E)	21-04-2020
Health Care and Social Assistance (Q)	21-04-2020
Other Services (S)	21-04-2020
Information Media and Telecommunications (J)	21-04-2020
Information Media and Telecommunications (J)	21-04-2020

Industry	Date
Mining (B)	21-04-2020
Information Media and Telecommunications (J)	21-04-2020
Other Services (S)	21-04-2020
Electricity, Gas, Water and Waste Services (D)	21-04-2020
Other Services (S)	21-04-2020
Other Services (S)	21-04-2020
Other Services (S)	21-04-2020
Construction (E)	21-04-2020
Construction (E)	21-04-2020
Professional, Scientific and Technical Services (M)	21-04-2020
Transport, Postal and Warehousing (I)	21-04-2020
Transport, Postal and Warehousing (I)	21-04-2020
Financial and Insurance Services (K)	21-04-2020
Construction (E)	21-04-2020
Construction (E)	21-04-2020
Retail Trade (G)	21-04-2020
Wholesale Trade (F)	21-04-2020
Mining (B)	20-04-2020
Other Services (S)	20-04-2020
Professional, Scientific and Technical Services (M)	20-04-2020
Construction (E)	20-04-2020
Financial and Insurance Services (K)	20-04-2020
Information Media and Telecommunications (J)	20-04-2020
Professional, Scientific and Technical Services (M)	16-04-2020
Information Media and Telecommunications (J)	16-04-2020
Professional, Scientific and Technical Services (M)	15-04-2020
Manufacturing (C)	14-04-2020
Professional, Scientific and Technical Services (M)	09-04-2020
Professional, Scientific and Technical Services (M)	08-04-2020
Professional, Scientific and Technical Services (M)	06-04-2020
Construction (E)	06-04-2020
Transport, Postal and Warehousing (I)	06-04-2020
Wholesale Trade (F)	31-03-2020
Construction (E)	31-03-2020
Transport, Postal and Warehousing (I)	25-03-2020
N/A	25-03-2020
Transport, Postal and Warehousing (I)	25-03-2020
Retail Trade (G)	23-03-2020
Retail Trade (G)	19-03-2020
Retail Trade (G)	18-03-2020
Financial and Insurance Services (K)	18-03-2020
Construction (E)	17-03-2020
Manufacturing (C)	13-03-2020

Industry	Date
Wholesale Trade (F)	11-03-2020
Transport, Postal and Warehousing (I)	23-02-2020
Retail Trade (G)	21-02-2020
Retail Trade (G)	19-02-2020
Construction (E)	05-02-2020
Other Services (S)	05-02-2020
Professional, Scientific and Technical Services (M)	31-01-2020
Professional, Scientific and Technical Services (M)	24-01-2020
Professional, Scientific and Technical Services (M)	16-01-2020
Professional, Scientific and Technical Services (M)	15-01-2020
Professional, Scientific and Technical Services (M)	10-01-2020
Professional, Scientific and Technical Services (M)	09-01-2020
Retail Trade (G)	07-01-2020
Professional, Scientific and Technical Services (M)	28-12-2019
Accommodation and Food Services (H)	27-12-2019
Professional, Scientific and Technical Services (M)	27-12-2019
Professional, Scientific and Technical Services (M)	26-12-2019
Professional, Scientific and Technical Services (M)	24-12-2019
Professional, Scientific and Technical Services (M)	23-12-2019
Professional, Scientific and Technical Services (M)	20-12-2019
Professional, Scientific and Technical Services (M)	18-12-2019
Construction (E)	18-12-2019
Professional, Scientific and Technical Services (M)	17-12-2019
Professional, Scientific and Technical Services (M)	02-12-2019
Professional, Scientific and Technical Services (M)	27-11-2019
Professional, Scientific and Technical Services (M)	13-11-2019
Professional, Scientific and Technical Services (M)	12-11-2019
Manufacturing (C)	12-11-2019
Transport, Postal and Warehousing (I)	08-11-2019
Professional, Scientific and Technical Services (M)	07-11-2019
Professional, Scientific and Technical Services (M)	06-11-2019
Professional, Scientific and Technical Services (M)	30-10-2019
Professional, Scientific and Technical Services (M)	25-10-2019
Electricity, Gas, Water and Waste Services (D)	21-10-2019
Construction (E)	16-10-2019
Wholesale Trade (F)	14-10-2019
Wholesale Trade (F)	11-10-2019
Professional, Scientific and Technical Services (M)	10-10-2019
Professional, Scientific and Technical Services (M)	26-09-2019
Professional, Scientific and Technical Services (M)	25-09-2019
Wholesale Trade (F)	23-09-2019
Professional, Scientific and Technical Services (M)	19-09-2019
Wholesale Trade (F)	18-09-2019

Industry	Date
Professional, Scientific and Technical Services (M)	17-09-2019
Wholesale Trade (F)	09-09-2019
Education and Training (P)	06-09-2019
Professional, Scientific and Technical Services (M)	06-09-2019
Professional, Scientific and Technical Services (M)	05-09-2019
Professional, Scientific and Technical Services (M)	04-09-2019
Professional, Scientific and Technical Services (M)	02-09-2019
Professional, Scientific and Technical Services (M)	30-08-2019
Professional, Scientific and Technical Services (M)	21-08-2019
Professional, Scientific and Technical Services (M)	20-08-2019
Professional, Scientific and Technical Services (M)	10-08-2019
Manufacturing (C)	08-08-2019
Professional, Scientific and Technical Services (M)	30-07-2019
Construction (E)	29-07-2019
Professional, Scientific and Technical Services (M)	26-07-2019
Professional, Scientific and Technical Services (M)	25-07-2019
Professional, Scientific and Technical Services (M)	24-07-2019
Professional, Scientific and Technical Services (M)	23-07-2019
Transport, Postal and Warehousing (I)	18-07-2019
Professional, Scientific and Technical Services (M)	11-07-2019
Professional, Scientific and Technical Services (M)	10-07-2019
Professional, Scientific and Technical Services (M)	05-07-2019
Professional, Scientific and Technical Services (M)	03-07-2019
Financial and Insurance Services (K)	30-06-2019
Professional, Scientific and Technical Services (M)	28-06-2019
Professional, Scientific and Technical Services (M)	25-06-2019
Wholesale Trade (F)	24-06-2019

Historical Timeline

Date	Type	Notes
21-05-2020	ASIC Document	#7EAX68614 Form 5011 Copy of Minutes of Meeting of Members, Creditors, Contributories or Committee of Inspection Other Than Under S.436e or S.439a
18-05-2020	ASIC Document	#7EAW57466 Form 506 Notification of Change of Address of Notification of Change Of Address of an External Administrator or Controller Or Scheme Administrator
30-04-2020	ASIC Document	#7EAW38789 Form 5011 Copy of Minutes of Meeting of Members, Creditors, Contributories or Committee of Inspection Under S.436e Or S.439a
20-04-2020	Status	The ASIC status was changed to Under External Administration And/Or Controller Appointed
20-04-2020	ASIC Document	#7EAV81862 Form 531 Declaration of Relevant Relationships And/or Indemnity Copy Of a Dirri #7EAV78252 Form 505 Notice By External Administrator/controller-Appoint/cease Appt of Administrator Under S.436a, 436b, 436c, 436e(4), 449b, 449c(1), 449c(4) or 449(6)
15-10-2019	ASIC Document	#7EAQ31263 Form 484 Change to Company Details Appointment or Cessation of A Company Officeholder
29-03-2019	ASIC Document	#7EAJ95080 Form 484 Change to Company Details Appointment or Cessation of A Company Officeholder
23-06-2017	Business Name	The business name Virgin Australia Holidays was added
27-05-2017	Business Name	The business name AFL Travel was added and Tigerair Travels was added
04-01-2017	Main Business Physical Address	The Main Business Physical Address was changed to QLD 4006 from QLD 4006
25-11-2016	ASIC Document	#7E8562420 Form 484 Change to Company Details Appointment or Cessation of A Company Officeholder
23-11-2016	Main Business Physical Address	The Main Business Physical Address was changed to QLD 4006 from QLD 4006
16-02-2016	ASIC Document	#7E7704673 Form 484 Change to Company Details Appointment or Cessation of A Company Officeholder
01-10-2015	ASIC Document	#7E7350490 Form 484 Change to Company Details Appointment or Cessation of A Company Officeholder
24-09-2014	Main Business Physical Address	The Main Business Physical Address was changed to QLD 4006 from QLD 4006
05-03-2014	Main Business Physical Address	The Main Business Physical Address was changed to QLD 4006 from QLD 4006
29-01-2014	Main Business Physical Address	The Main Business Physical Address was changed to QLD 4006 from QLD 4006
31-10-2013	ASIC Document	#7E5618079 Form 484 Change to Company Details Change Officeholder Name or Address Appointment or Cessation of a Company Officeholder
04-04-2013	ASIC Document	#7E5130421 Form 484 Change to Company Details Change Officeholder Name Or Address
15-03-2013	ASIC Document	#7E5089257 Form 484 Change to Company Details Change Officeholder Name Or Address

Date	Type	Notes
26-06-2012	ASIC Document	#7E4542418 Form 484 Change to Company Details Change Officeholder Name Or Address
25-01-2012	ASIC Document	#026016905 Form 312 Notification of Release of Property #026016903 Form 312 Notification of Release of Property
24-01-2012	ASIC Document	#026016898 Form 309 Notification of Details of a Charge #026016890 Form 309 Notification of Details of a Charge
23-01-2012	ASIC Document	#026016897 Form 309 Notification of Details of a Charge
22-12-2011	ASIC Document	#026016839 Form 312 Notification of Release of Property #026016838 Form 312 Notification of Release of Property
21-12-2011	ASIC Document	#027189867 Form 309 Notification of Details of a Charge
12-12-2011	ASIC Document	#027189790 Form 309 Notification of Details of a Charge
02-12-2011	ASIC Document	#027853764 Form 312 Notification of Release of Property #027853765 Form 312 Notification of Release of Property
23-11-2011	ASIC Document	#026016788 Form 309 Notification of Details of a Charge
22-11-2011	ASIC Document	#027189739 Form 309 Notification of Details of a Charge
21-11-2011	ASIC Document	#026016789 Form 309 Notification of Details of a Charge
08-11-2011	ASIC Document	#026016775 Form 309 Notification of Details of a Charge
14-10-2011	ASIC Document	#027189602 Form 309 Notification of Details of a Charge
26-09-2011	ASIC Document	#027788400 Form 484 Change to Company Details Change Officeholder Name Or Address
06-09-2011	ASIC Document	#026016666 Form 309 Notification of Details of a Charge
31-08-2011	ASIC Document	#027189460 Form 309 Notification of Details of a Charge
28-07-2011	ASIC Document	#027189343 Form 309 Notification of Details of a Charge

Date	Type	Notes
18-07-2011	ASIC Document	#027540776 Form 484 Change to Company Details Appointment or Cessation of A Company Officeholder
20-06-2011	ASIC Document	#026016479 Form 309 Notification of Details of a Charge
10-06-2011	ASIC Document	#7E3729843 Form 484 Change to Company Details Change Officeholder Name Or Address
08-06-2011	ASIC Document	#027189111 Form 309 Notification of Details of a Charge
23-05-2011	ASIC Document	#026016433 Form 309 Notification of Details of a Charge
20-05-2011	ASIC Document	#7E3682130 Form 484 Change to Company Details Appointment or Cessation of A Company Officeholder
12-05-2011	ASIC Document	#026016416 Form 309 Notification of Details of a Charge
10-05-2011	ASIC Document	#026016408 Form 309 Notification of Details of a Charge
04-05-2011	Main Name	The Main Name was changed to VIRGIN AUSTRALIA AIRLINES PTY LTD from VIRGIN BLUE AIRLINES PTY LIMITED
04-05-2011	ASIC Document	#026016378 Form 312 Notification of Discharge
29-04-2011	ASIC Document	#025132085 Form 205 Notification of Resolution Changing Company Name
27-04-2011	ASIC Document	#026621238 Form 488 Application to Change Review Date of a Company or Scheme Synchronise Review Date With Holding Company - No Fee
21-04-2011	ASIC Document	#026026977 Form 309 Notification of Details of a Charge
18-04-2011	ASIC Document	#026016380 Form 309 Notification of Details of a Charge #026016361 Form 309 Notification of Details of a Charge
04-04-2011	ASIC Document	#026016277 Form 312 Notification of Discharge
31-03-2011	ASIC Document	#026016274 Form 309 Notification of Details of a Charge
25-03-2011	ASIC Document	#026016195 Form 309 Notification of Details of a Charge
23-03-2011	ASIC Document	#7E3558913 Form 484 Change to Company Details Change Officeholder Name Or Address

Date	Type	Notes
18-03-2011	ASIC Document	#026026863 Form 312 Notification of Discharge #026026861 Form 312 Notification of Discharge #026016189 Form 312 Notification of Discharge #026016188 Form 312 Notification of Discharge
11-03-2011	ASIC Document	#026026802 Form 309 Notification of Details of a Charge #026026796 Form 309 NOTIFICATION OF DETAILS OF A CHARGE #7E3531795 Form 484 CHANGE TO COMPANY DETAILS APPOINTMENT OR CESSATION OF A COMPANY OFFICEHOLDER
03-03-2011	ASIC Document	#026016166 Form 309 NOTIFICATION OF DETAILS OF A CHARGE
17-01-2011	ASIC Document	#7E3416919 Form 484 CHANGE TO COMPANY DETAILS APPOINTMENT OR CESSATION OF A COMPANY OFFICEHOLDER
23-12-2010	ASIC Document	#027412855 Form 309 NOTIFICATION OF DETAILS OF A CHARGE #027412854 Form 309 NOTIFICATION OF DETAILS OF A CHARGE
16-12-2010	ASIC Document	#024988990 Form 309 NOTIFICATION OF DETAILS OF A CHARGE
26-11-2010	ASIC Document	#7E3323851 Form 484 CHANGE TO COMPANY DETAILS APPOINTMENT OR CESSATION OF A COMPANY OFFICEHOLDER
08-11-2010	ASIC Document	#027318630 Form 312 NOTIFICATION OF DISCHARGE
29-09-2010	ASIC Document	#026026165 Form 309 NOTIFICATION OF DETAILS OF A CHARGE
16-09-2010	ASIC Document	#027099828 Form 312 NOTIFICATION OF DISCHARGE
15-09-2010	ASIC Document	#024191662 Form 309 NOTIFICATION OF DETAILS OF A CHARGE
09-09-2010	ASIC Document	#7E3160815 Form 484 CHANGE TO COMPANY DETAILS APPOINTMENT OR CESSATION OF A COMPANY OFFICEHOLDER
30-07-2010	ASIC Document	#024979956 Form 309 NOTIFICATION OF DETAILS OF A CHARGE
24-09-2009	Main Business Physical Address	The Main Business Physical Address was changed to QLD 4006 from QLD 4006
01-01-2009	Main Business Physical Address	The Main Business Physical Address was changed to QLD 4006 from QLD 4004
26-04-2007	Business Name	The business name IN-BAR-GO was removed
23-02-2007	Business Name	The business name CHOW N CIAO was removed
30-01-2007	Business Name	The business name BLUE AIRLINES was removed

Date	Type	Notes
07-05-2006	Business Name	The business name VIRGIN BLUE HOLIDAYS was removed
12-09-2005	Business Name	The business name POLYNESIAN BLUE was added
25-03-2004	Main Business Physical Address	The Main Business Physical Address was changed to QLD 4004 from QLD 4006
23-10-2003	Business Name	The business name CHOW N CIAO was added
31-08-2003	Business Name	The business name BLUE AIRLINES was added
01-12-2002	Business Name	The business name VIRGIN BLUE HOLIDAYS was added
12-09-2002	Business Name	The business name IN-BAR-GO was added
06-05-2002	Main Name	The Main Name was changed to VIRGIN BLUE AIRLINES PTY LIMITED from VIRGIN AUSTRALIA (OPERATIONS) PTY LIMITED
18-02-2002	Main Trading Name	The Main Trading Name was changed to VIRGIN BLUE
10-10-2000	Main Name	The Main Name was changed to VIRGIN AUSTRALIA (OPERATIONS) PTY LIMITED from VIRGIN AUSTRALIA (OPERATIONS) PTY LTD
01-07-2000	Goods And Services Tax	The Goods and Services Tax was changed to Currently registered for GST
21-05-2000	Main Name	The Main Name was changed to VIRGIN AUSTRALIA (OPERATIONS) PTY LTD
21-05-2000	Main Business Physical Address	The Main Business Physical Address was changed to QLD 4006
24-11-1999	Entity Status	The Entity Status was changed to Active

Disclaimer

CreditorWatch is committed to ensuring that the information provided is accurate and comprehensive however due to data being received from sources not controlled by CreditorWatch we cannot guarantee that it is complete, verified or free of errors. The information should therefore be used in conjunction with your own investigations and you should not rely solely on this information when making credit or financial decisions. To the extent permitted by law, CreditorWatch will not be held responsible for any errors or omissions therein concerning the information sourced and published in its publications, websites, API or emails.

PRIORITY SEARCH CERTIFICATE

Issued by the International Registry of International Interests in Aircraft Equipment

Certificate Number

1360017

This certificate was created on 06 May 2020 at 22:56:15 GMT

Requested by: Ashleigh Taylor-reeve

Beneficiary of Priority Search Certificate: InfoTrack

Search Criteria

Manufacturer: CFM
Model Designation: CFM56-7
Manufacturer's Serial Number: 888473

06 Jan 2017 19:05:06 GMT

File Number: 1358469

Registration

Type: International Interest
Fractional or Partial Interest: 100.000000%
Debtor: Wells Fargo Bank Northwest, National Association, as Owner Trustee*
(aimee.b.johnson@wellsfargo.com)
Creditor: MUFG Union Bank, N.A.* (Terumi.Nishi@unionbank.com)
Right to Discharge Holder: MUFG Union Bank, N.A.* (Terumi.Nishi@unionbank.com)

06 Jan 2017 19:38:07 GMT

File Number: 1358476

Registration

Type: Sale
Fractional or Partial Interest: 100.000000%
Seller: Wells Fargo Bank Northwest, National Association, as Owner Trustee*
(aimee.b.johnson@wellsfargo.com)
Buyer: Willis Lease Finance Corporation (dskinner@willislease.com)

06 Jan 2017 19:43:05 GMT

File Number: 1358478

Registration

Type: Sale
Fractional or Partial Interest: 100.000000%
Seller: Willis Lease Finance Corporation (dskinner@willislease.com)
Buyer: Wells Fargo Bank Northwest, National Association, as Owner Trustee*
(aimee.b.johnson@wellsfargo.com)

01 Feb 2017 22:24:01 GMT

File Number: 1364613

Registration

Type: International Interest
Fractional or Partial Interest: 100.000000%
Debtor: Southwest Airlines Co. (irclosings@gilchristaviation.com)
Creditor: Wells Fargo Bank Northwest, National Association, as Owner Trustee*
(aimee.b.johnson@wellsfargo.com)
Right to Discharge Holder: Deutsche Bank Trust Company Americas (louis.bodi@db.com)

Transfer of Right to Discharge

Date/Time	Transferor	Transferee
25 Sep 2017 18:58:33 GMT	Wells Fargo Bank Northwest, National Association, as Owner Trustee*	Deutsche Bank Trust Company Americas

01 Feb 2017 22:30:02 GMT		File Number: 1364614
Registration	Type:	Assignment of an International Interest
	Interest being Assigned:	1364613
	Fractional or Partial Interest:	100.000000%
	Assignor:	Wells Fargo Bank Northwest, National Association, as Owner Trustee* (aimee.b.johnson@wellsfargo.com)
	Assignee:	MUFG Union Bank, N.A.* (Terumi.Nishi@unionbank.com)
	Right to Discharge Holder:	MUFG Union Bank, N.A.* (Terumi.Nishi@unionbank.com)

08 Sep 2017 20:15:01 GMT		File Number: 1430037
Discharge	Type:	International Interest
	Discharge of File:	1358469
	Fractional or Partial Interest:	100.000000%
	Remaining Interest:	0.000000%
	Date of Discharge:	08 Sep 2017
	Debtor:	Wells Fargo Bank Northwest, National Association, as Owner Trustee* (aimee.b.johnson@wellsfargo.com)
	Creditor:	MUFG Union Bank, N.A.* (Terumi.Nishi@unionbank.com)

08 Sep 2017 20:15:04 GMT		File Number: 1430038
Discharge	Type:	Assignment of an International Interest
	Discharge of File:	1364614
	Fractional or Partial Interest:	100.000000%
	Remaining Interest:	0.000000%
	Date of Discharge:	08 Sep 2017
	Assignor:	Wells Fargo Bank Northwest, National Association, as Owner Trustee* (aimee.b.johnson@wellsfargo.com)
	Assignee:	MUFG Union Bank, N.A.* (Terumi.Nishi@unionbank.com)

08 Sep 2017 20:15:08 GMT		File Number: 1430039
Registration	Type:	International Interest
	Fractional or Partial Interest:	100.000000%
	Debtor:	Wells Fargo Bank Northwest, National Association, as Owner Trustee* (aimee.b.johnson@wellsfargo.com)
	Creditor:	Deutsche Bank Trust Company Americas (louis.bodi@db.com)
	Right to Discharge Holder:	Deutsche Bank Trust Company Americas (louis.bodi@db.com)

08 Sep 2017 20:15:11 GMT		File Number: 1430040
Registration	Type:	Assignment of an International Interest
	Interest being Assigned:	1364613
	Fractional or Partial Interest:	100.000000%
	Assignor:	Wells Fargo Bank Northwest, National Association, as Owner Trustee* (aimee.b.johnson@wellsfargo.com)
	Assignee:	Deutsche Bank Trust Company Americas (louis.bodi@db.com)
	Right to Discharge Holder:	Deutsche Bank Trust Company Americas (louis.bodi@db.com)

09 Jul 2018 14:09:05 GMT

File Number: 1533354

Registration

Type: International Interest
Fractional or Partial Interest: 100.000000%
Debtor: Southwest Airlines Co. (irclosings@gilchristaviation.com)
Creditor: Wells Fargo Trust Company, National Association, as Owner Trustee*
(aimee.b.johnson@wellsfargo.com)
Right to Discharge Holder: Deutsche Bank Trust Company Americas (louis.bodi@db.com)

Transfer of Right to Discharge

Date/Time	Transferor	Transferee
09 Jul 2018 14:33:04 GMT	Wells Fargo Trust Company, National Association, as Owner Trustee*	Deutsche Bank Trust Company Americas

09 Jul 2018 14:31:04 GMT

File Number: 1533363

Registration

Type: Assignment of an International Interest
Interest being Assigned: 1533354
Fractional or Partial Interest: 100.000000%
Assignor: Wells Fargo Trust Company, National Association, as Owner Trustee*
(aimee.b.johnson@wellsfargo.com)
Assignee: Deutsche Bank Trust Company Americas (louis.bodi@db.com)
Right to Discharge Holder: Deutsche Bank Trust Company Americas (louis.bodi@db.com)

29 Aug 2019 20:13:01 GMT

File Number: 1671494

Registration

Type: International Interest
Fractional or Partial Interest: 100.000000%
Debtor: VB Leaseco Pty Ltd (billy.mayberry@virginaustralia.com)
Creditor: Wells Fargo Trust Company, National Association, as Owner Trustee*
(aimee.b.johnson@wellsfargo.com)
Right to Discharge Holder: Deutsche Bank Trust Company Americas (louis.bodi@db.com)

Transfer of Right to Discharge

Date/Time	Transferor	Transferee
29 Aug 2019 20:13:32 GMT	Wells Fargo Trust Company, National Association, as Owner Trustee*	Deutsche Bank Trust Company Americas

29 Aug 2019 20:13:08 GMT

File Number: 1671495

Registration

Type: Assignment of an International Interest
Interest being Assigned: 1671494
Fractional or Partial Interest: 100.000000%
Assignor: Wells Fargo Trust Company, National Association, as Owner Trustee*
(aimee.b.johnson@wellsfargo.com)
Assignee: Deutsche Bank Trust Company Americas (louis.bodi@db.com)
Right to Discharge Holder: Deutsche Bank Trust Company Americas (louis.bodi@db.com)

29 Aug 2019 20:13:16 GMT		File Number: 1671496	
Registration	Type:	International Interest	
	Fractional or Partial Interest:	100.000000%	
	Debtor:	Virgin Australia Airlines Pty Limited* (billy.mayberry@virginaustralia.com)	
	Creditor:	VB Leaseco Pty Ltd (billy.mayberry@virginaustralia.com)	
	Right to Discharge Holder:	Deutsche Bank Trust Company Americas (louis.bodi@db.com)	
Transfer of Right to Discharge			
	Date/Time	Transferor	Transferee
	29 Aug 2019 20:13:44 GMT	VB Leaseco Pty Ltd	Deutsche Bank Trust Company Americas

29 Aug 2019 20:13:24 GMT		File Number: 1671497	
Registration	Type:	Assignment of an International Interest	
	Interest being Assigned:	1671496	
	Fractional or Partial Interest:	100.000000%	
	Assignor:	VB Leaseco Pty Ltd (billy.mayberry@virginaustralia.com)	
	Assignee:	Wells Fargo Trust Company, National Association, as Owner Trustee* (aimee.b.johnson@wellsfargo.com)	
Right to Discharge Holder:	Deutsche Bank Trust Company Americas (louis.bodi@db.com)		
Transfer of Right to Discharge			
	Date/Time	Transferor	Transferee
	29 Aug 2019 20:13:36 GMT	Wells Fargo Trust Company, National Association, as Owner Trustee*	Deutsche Bank Trust Company Americas

29 Aug 2019 20:13:28 GMT		File Number: 1671498
Registration	Type:	Assignment of an International Interest
	Interest being Assigned:	1671497
	Fractional or Partial Interest:	100.000000%
	Assignor:	Wells Fargo Trust Company, National Association, as Owner Trustee* (aimee.b.johnson@wellsfargo.com)
	Assignee:	Deutsche Bank Trust Company Americas (louis.bodi@db.com)
Right to Discharge Holder:	Deutsche Bank Trust Company Americas (louis.bodi@db.com)	

09 Sep 2019 19:50:05 GMT		File Number: 1675270
Discharge	Type:	International Interest
	Discharge of File:	1364613
	Fractional or Partial Interest:	100.000000%
	Remaining Interest:	0.000000%
	Date of Discharge:	09 Sep 2019
	Debtor:	Southwest Airlines Co. (irclosings@gilchristaviation.com)
	Creditor:	Wells Fargo Trust Company, National Association, as Owner Trustee* (aimee.b.johnson@wellsfargo.com)

09 Sep 2019 19:50:09 GMT		File Number: 1675271
Discharge	Type:	Assignment of an International Interest
	Discharge of File:	1430040
	Fractional or Partial Interest:	100.000000%
	Remaining Interest:	0.000000%
	Date of Discharge:	09 Sep 2019
	Assignor:	Wells Fargo Trust Company, National Association, as Owner Trustee* (aimee.b.johnson@wellsfargo.com)
	Assignee:	Deutsche Bank Trust Company Americas (louis.bodi@db.com)
09 Sep 2019 19:50:13 GMT		File Number: 1675272
Discharge	Type:	International Interest
	Discharge of File:	1533354
	Fractional or Partial Interest:	100.000000%
	Remaining Interest:	0.000000%
	Date of Discharge:	09 Sep 2019
	Debtor:	Southwest Airlines Co. (irclosings@gilchristaviation.com)
	Creditor:	Wells Fargo Trust Company, National Association, as Owner Trustee* (aimee.b.johnson@wellsfargo.com)
09 Sep 2019 19:50:17 GMT		File Number: 1675273
Discharge	Type:	Assignment of an International Interest
	Discharge of File:	1533363
	Fractional or Partial Interest:	100.000000%
	Remaining Interest:	0.000000%
	Date of Discharge:	09 Sep 2019
	Assignor:	Wells Fargo Trust Company, National Association, as Owner Trustee* (aimee.b.johnson@wellsfargo.com)
	Assignee:	Deutsche Bank Trust Company Americas (louis.bodi@db.com)

End of List

In conformity with Article 22(3) of the Cape Town Convention "international interest" in this certificate denotes an interest which the creditor has acquired or intends to acquire and is not intended to indicate whether what is registered is an international interest or a prospective international interest. Similarly, with reference to Article 19(4) and 19(5) of the Cape Town Convention, "assignment" is not intended to indicate whether what is registered is an assignment or a prospective assignment, and, in conformity with Article III of the Aircraft Protocol, "sale" is not intended to indicate whether what is registered is a sale or a prospective sale.

The International Registry system is designed to use percentages with a maximum of six decimal places when recording fractional and partial interests in aircraft objects e.g. 12.123456%. Please consider that certain fractions cannot be fully represented within six decimal places. Percentages shown are of the full aircraft object.

*The International Registry was notified that this entity had a change of name within the meaning set out in the Regulations and Procedures for the International Registry.

Name Change History			
Entity Reference	Old Name	New Name	Date Changed on International Registry
0000011534	Union Bank, N.A.	MUFG Union Bank, N.A.	17-Nov-2014
0000011534	Union Bank of California, N.A.	Union Bank, N.A.	22-Jul-2009
0000044112	Wells Fargo Bank Northwest, National Association, as Owner Trustee	Wells Fargo Trust Company, National Association, as Owner Trustee	04-May-2018
0214802006	Virgin Blue Airlines Pty Limited	Virgin Australia Airlines Pty Limited	11-May-2011

Supplementary Priority Search Information

This information table contains supplementary priority search information provided pursuant to Section 7.8 of the Regulations for the International Registry. Supplementary priority search information is provided for information purposes only to assist users in reviewing the registered information contained in the priority search certificate. **Users must review all registered information contained in the priority search certificate and not just the information contained in the supplementary priority search information.** In the case of inconsistency between the registered information contained in the priority search certificate and the supplementary priority search information, the registered information contained in the priority search certificate shall prevail. Any such inconsistency and any inaccuracy discovered should be reported to the Registrar within 72 hours of receipt of the priority search certificate by the user.

Date	Type	File Number	Fractional or Partial Interest	Fully Discharged	Discharged by File Number(s)	Date of Full Discharge
06 Jan 2017 19:05:06 GMT	International Interest	1358469	100.000000%	YES	1430037	08 Sep 2017
06 Jan 2017 19:38:07 GMT	Sale	1358476	100.000000%	-	-	-
06 Jan 2017 19:43:05 GMT	Sale	1358478	100.000000%	-	-	-
01 Feb 2017 22:24:01 GMT	International Interest	1364613	100.000000%	YES	1675270	09 Sep 2019
01 Feb 2017 22:30:02 GMT	Assignment of an International Interest	1364614	100.000000%	YES	1430038	08 Sep 2017
08 Sep 2017 20:15:08 GMT	International Interest	1430039	100.000000%	-	-	-
08 Sep 2017 20:15:11 GMT	Assignment of an International Interest	1430040	100.000000%	YES	1675271	09 Sep 2019
09 Jul 2018 14:09:05 GMT	International Interest	1533354	100.000000%	YES	1675272	09 Sep 2019
09 Jul 2018 14:31:04 GMT	Assignment of an International Interest	1533363	100.000000%	YES	1675273	09 Sep 2019
29 Aug 2019 20:13:01 GMT	International Interest	1671494	100.000000%	-	-	-
29 Aug 2019 20:13:08 GMT	Assignment of an International Interest	1671495	100.000000%	-	-	-
29 Aug 2019 20:13:16 GMT	International Interest	1671496	100.000000%	-	-	-
29 Aug 2019 20:13:24 GMT	Assignment of an International Interest	1671497	100.000000%	-	-	-
29 Aug 2019 20:13:28 GMT	Assignment of an International Interest	1671498	100.000000%	-	-	-

PRIORITY SEARCH CERTIFICATE

Issued by the International Registry of International Interests in Aircraft Equipment

Certificate Number

1360024

This certificate was created on 06 May 2020 at 22:56:15 GMT

Requested by: Ashleigh Taylor-reeve

Beneficiary of Priority Search Certificate: InfoTrack

Search Criteria

Manufacturer: CFM
Model Designation: CFM56-7
Manufacturer's Serial Number: 897193

13 Dec 2012 22:49:52 GMT

File Number: 919158

Registration

Type: International Interest
Fractional or Partial Interest: 100.000000%
Debtor: SANAD AERO SOLUTIONS INVESTMENTS LLC (pshort@sanad.ae)
Creditor: Abu Dhabi National Leasing LLC (Urvi.Widhani@bankfab.com)
Right to Discharge Holder: Abu Dhabi National Leasing LLC (Urvi.Widhani@bankfab.com)

22 Nov 2016 13:24:01 GMT

File Number: 1341695

Discharge

Type: International Interest
Discharge of File: 919158
Fractional or Partial Interest: 100.000000%
Remaining Interest: 0.000000%
Date of Discharge: 22 Nov 2016
Debtor: SANAD AERO SOLUTIONS INVESTMENTS LLC (pshort@sanad.ae)
Creditor: Abu Dhabi National Leasing LLC (Urvi.Widhani@bankfab.com)

23 Nov 2016 21:00:11 GMT

File Number: 1342389

Registration

Type: International Interest
Fractional or Partial Interest: 100.000000%
Debtor: Wells Fargo Bank Northwest, National Association, as Owner Trustee* (aimee.b.johnson@wellsfargo.com)
Creditor: MUFG Union Bank, N.A.* (Terumi.Nishi@unionbank.com)
Right to Discharge Holder: MUFG Union Bank, N.A.* (Terumi.Nishi@unionbank.com)

23 Nov 2016 21:03:11 GMT

File Number: 1342392

Registration

Type: Sale
Fractional or Partial Interest: 100.000000%
Seller: SANAD AERO SOLUTIONS INVESTMENTS LLC (pshort@sanad.ae)
Buyer: Wells Fargo Bank Northwest, National Association, as Owner Trustee* (aimee.b.johnson@wellsfargo.com)

30 Jun 2017 20:34:01 GMT		File Number: 1411902						
Registration	Type:	International Interest						
	Fractional or Partial Interest:	100.000000%						
	Debtor:	Southwest Airlines Co. (irclosings@gilchristaviation.com)						
	Creditor:	Wells Fargo Bank Northwest, National Association, as Owner Trustee* (aimee.b.johnson@wellsfargo.com)						
	Right to Discharge Holder:	Deutsche Bank Trust Company Americas (louis.bodi@db.com)						
Transfer of Right to Discharge								
<table border="1"> <thead> <tr> <th>Date/Time</th> <th>Transferor</th> <th>Transferee</th> </tr> </thead> <tbody> <tr> <td>25 Sep 2017 21:47:14 GMT</td> <td>Wells Fargo Bank Northwest, National Association, as Owner Trustee*</td> <td>Deutsche Bank Trust Company Americas</td> </tr> </tbody> </table>			Date/Time	Transferor	Transferee	25 Sep 2017 21:47:14 GMT	Wells Fargo Bank Northwest, National Association, as Owner Trustee*	Deutsche Bank Trust Company Americas
Date/Time	Transferor	Transferee						
25 Sep 2017 21:47:14 GMT	Wells Fargo Bank Northwest, National Association, as Owner Trustee*	Deutsche Bank Trust Company Americas						

30 Jun 2017 20:37:05 GMT		File Number: 1411905
Registration	Type:	Assignment of an International Interest
	Interest being Assigned:	1411902
	Fractional or Partial Interest:	100.000000%
	Assignor:	Wells Fargo Bank Northwest, National Association, as Owner Trustee* (aimee.b.johnson@wellsfargo.com)
	Assignee:	MUFG Union Bank, N.A.* (Terumi.Nishi@unionbank.com)
Right to Discharge Holder:	MUFG Union Bank, N.A.* (Terumi.Nishi@unionbank.com)	

25 Sep 2017 21:47:01 GMT		File Number: 1438021
Discharge	Type:	International Interest
	Discharge of File:	1342389
	Fractional or Partial Interest:	100.000000%
	Remaining Interest:	0.000000%
	Date of Discharge:	25 Sep 2017
	Debtor:	Wells Fargo Bank Northwest, National Association, as Owner Trustee* (aimee.b.johnson@wellsfargo.com)
	Creditor:	MUFG Union Bank, N.A.* (Terumi.Nishi@unionbank.com)

25 Sep 2017 21:47:04 GMT		File Number: 1438022
Discharge	Type:	Assignment of an International Interest
	Discharge of File:	1411905
	Fractional or Partial Interest:	100.000000%
	Remaining Interest:	0.000000%
	Date of Discharge:	25 Sep 2017
	Assignor:	Wells Fargo Bank Northwest, National Association, as Owner Trustee* (aimee.b.johnson@wellsfargo.com)
	Assignee:	MUFG Union Bank, N.A.* (Terumi.Nishi@unionbank.com)

25 Sep 2017 21:47:08 GMT		File Number: 1438023
Registration	Type:	International Interest
	Fractional or Partial Interest:	100.000000%
	Debtor:	Wells Fargo Bank Northwest, National Association, as Owner Trustee* (aimee.b.johnson@wellsfargo.com)
	Creditor:	Deutsche Bank Trust Company Americas (louis.bodi@db.com)
	Right to Discharge Holder:	Deutsche Bank Trust Company Americas (louis.bodi@db.com)

25 Sep 2017 21:47:11 GMT		File Number: 1438024	
Registration	Type:	Assignment of an International Interest	
	Interest being Assigned:	1411902	
	Fractional or Partial Interest:	100.000000%	
	Assignor:	Wells Fargo Bank Northwest, National Association, as Owner Trustee* (aimee.b.johnson@wellsfargo.com)	
	Assignee:	Deutsche Bank Trust Company Americas (louis.bodi@db.com)	
	Right to Discharge Holder:	Deutsche Bank Trust Company Americas (louis.bodi@db.com)	
30 Apr 2019 16:50:38 GMT		File Number: 1631607	
Discharge	Type:	International Interest	
	Discharge of File:	1411902	
	Fractional or Partial Interest:	100.000000%	
	Remaining Interest:	0.000000%	
	Date of Discharge:	30 Apr 2019	
	Debtor:	Southwest Airlines Co. (irclosings@gilchristaviation.com)	
	Creditor:	Wells Fargo Trust Company, National Association, as Owner Trustee* (aimee.b.johnson@wellsfargo.com)	
30 Apr 2019 16:50:41 GMT		File Number: 1631608	
Discharge	Type:	Assignment of an International Interest	
	Discharge of File:	1438024	
	Fractional or Partial Interest:	100.000000%	
	Remaining Interest:	0.000000%	
	Date of Discharge:	30 Apr 2019	
	Assignor:	Wells Fargo Trust Company, National Association, as Owner Trustee* (aimee.b.johnson@wellsfargo.com)	
	Assignee:	Deutsche Bank Trust Company Americas (louis.bodi@db.com)	
30 May 2019 21:08:13 GMT		File Number: 1639898	
Registration	Type:	International Interest	
	Fractional or Partial Interest:	100.000000%	
	Debtor:	VB Leaseco Pty Ltd (billy.mayberry@virginaustralia.com)	
	Creditor:	Wells Fargo Trust Company, National Association, as Owner Trustee* (aimee.b.johnson@wellsfargo.com)	
	Right to Discharge Holder:	Deutsche Bank Trust Company Americas (louis.bodi@db.com)	
Transfer of Right to Discharge			
	Date/Time	Transferor	Transferee
	30 May 2019 21:08:21 GMT	Wells Fargo Trust Company, National Association, as Owner Trustee*	Deutsche Bank Trust Company Americas
30 May 2019 21:08:17 GMT		File Number: 1639899	
Registration	Type:	Assignment of an International Interest	
	Interest being Assigned:	1639898	
	Fractional or Partial Interest:	100.000000%	
	Assignor:	Wells Fargo Trust Company, National Association, as Owner Trustee* (aimee.b.johnson@wellsfargo.com)	
	Assignee:	Deutsche Bank Trust Company Americas (louis.bodi@db.com)	
	Right to Discharge Holder:	Deutsche Bank Trust Company Americas (louis.bodi@db.com)	

30 May 2019 21:08:25 GMT		File Number: 1639900	
Registration	Type:	International Interest	
	Fractional or Partial Interest:	100.000000%	
	Debtor:	Virgin Australia Airlines Pty Limited* (billy.mayberry@virginaustralia.com)	
	Creditor:	VB Leaseco Pty Ltd (billy.mayberry@virginaustralia.com)	
	Right to Discharge Holder:	Deutsche Bank Trust Company Americas (louis.bodi@db.com)	
Transfer of Right to Discharge			
	Date/Time	Transferor	Transferee
	30 May 2019 21:08:39 GMT	VB Leaseco Pty Ltd	Deutsche Bank Trust Company Americas

30 May 2019 21:08:28 GMT		File Number: 1639901	
Registration	Type:	Assignment of an International Interest	
	Interest being Assigned:	1639900	
	Fractional or Partial Interest:	100.000000%	
	Assignor:	VB Leaseco Pty Ltd (billy.mayberry@virginaustralia.com)	
	Assignee:	Wells Fargo Trust Company, National Association, as Owner Trustee* (aimee.b.johnson@wellsfargo.com)	
Right to Discharge Holder:	Deutsche Bank Trust Company Americas (louis.bodi@db.com)		
Transfer of Right to Discharge			
	Date/Time	Transferor	Transferee
	30 May 2019 21:08:36 GMT	Wells Fargo Trust Company, National Association, as Owner Trustee*	Deutsche Bank Trust Company Americas

30 May 2019 21:08:32 GMT		File Number: 1639902
Registration	Type:	Assignment of an International Interest
	Interest being Assigned:	1639901
	Fractional or Partial Interest:	100.000000%
	Assignor:	Wells Fargo Trust Company, National Association, as Owner Trustee* (aimee.b.johnson@wellsfargo.com)
	Assignee:	Deutsche Bank Trust Company Americas (louis.bodi@db.com)
Right to Discharge Holder:	Deutsche Bank Trust Company Americas (louis.bodi@db.com)	

End of List

In conformity with Article 22(3) of the Cape Town Convention "international interest" in this certificate denotes an interest which the creditor has acquired or intends to acquire and is not intended to indicate whether what is registered is an international interest or a prospective international interest. Similarly, with reference to Article 19(4) and 19(5) of the Cape Town Convention, "assignment" is not intended to indicate whether what is registered is an assignment or a prospective assignment, and, in conformity with Article III of the Aircraft Protocol, "sale" is not intended to indicate whether what is registered is a sale or a prospective sale.

The International Registry system is designed to use percentages with a maximum of six decimal places when recording fractional and partial interests in aircraft objects e.g. 12.123456%. Please consider that certain fractions cannot be fully represented within six decimal places. Percentages shown are of the full aircraft object.

*The International Registry was notified that this entity had a change of name within the meaning set out in the Regulations and Procedures for the International Registry.

Name Change History			
Entity Reference	Old Name	New Name	Date Changed on International Registry
0000011534	Union Bank, N.A.	MUFG Union Bank, N.A.	17-Nov-2014
0000011534	Union Bank of California, N.A.	Union Bank, N.A.	22-Jul-2009
0000044112	Wells Fargo Bank Northwest, National Association, as Owner Trustee	Wells Fargo Trust Company, National Association, as Owner Trustee	04-May-2018
0214802006	Virgin Blue Airlines Pty Limited	Virgin Australia Airlines Pty Limited	11-May-2011

Supplementary Priority Search Information

This information table contains supplementary priority search information provided pursuant to Section 7.8 of the Regulations for the International Registry. Supplementary priority search information is provided for information purposes only to assist users in reviewing the registered information contained in the priority search certificate. **Users must review all registered information contained in the priority search certificate and not just the information contained in the supplementary priority search information.** In the case of inconsistency between the registered information contained in the priority search certificate and the supplementary priority search information, the registered information contained in the priority search certificate shall prevail. Any such inconsistency and any inaccuracy discovered should be reported to the Registrar within 72 hours of receipt of the priority search certificate by the user.

Date	Type	File Number	Fractional or Partial Interest	Fully Discharged	Discharged by File Number(s)	Date of Full Discharge
13 Dec 2012 22:49:52 GMT	International Interest	919158...	100.000000%	YES	1341695	22 Nov 2016
23 Nov 2016 21:00:11 GMT	International Interest	1342389...	100.000000%	YES	1438021	25 Sep 2017
23 Nov 2016 21:03:11 GMT	Sale	1342392...	100.000000%	-	-	-
30 Jun 2017 20:34:01 GMT	International Interest	1411902...	100.000000%	YES	1631607	30 Apr 2019
30 Jun 2017 20:37:05 GMT	Assignment of an International Interest	1411905...	100.000000%	YES	1438022	25 Sep 2017
25 Sep 2017 21:47:08 GMT	International Interest	1438023...	100.000000%	-	-	-
25 Sep 2017 21:47:11 GMT	Assignment of an International Interest	1438024...	100.000000%	YES	1631608	30 Apr 2019
30 May 2019 21:08:13 GMT	International Interest	1639898...	100.000000%	-	-	-
30 May 2019 21:08:17 GMT	Assignment of an International Interest	1639899...	100.000000%	-	-	-
30 May 2019 21:08:25 GMT	International Interest	1639900...	100.000000%	-	-	-
30 May 2019 21:08:28 GMT	Assignment of an International Interest	1639901...	100.000000%	-	-	-
30 May 2019 21:08:32 GMT	Assignment of an International Interest	1639902...	100.000000%	-	-	-

PRIORITY SEARCH CERTIFICATE

Issued by the International Registry of International Interests in Aircraft Equipment

Certificate Number

1360023

This certificate was created on 06 May 2020 at 22:56:15 GMT

Requested by: Ashleigh Taylor-reeve

Beneficiary of Priority Search Certificate: InfoTrack

Search Criteria

Manufacturer: CFM
Model Designation: CFM56-7
Manufacturer's Serial Number: 896999

16 Mar 2009 15:15:33 GMT

File Number: 321885

Registration

Type: International Interest
Fractional or Partial Interest: 100.000000%
Debtor: Wells Fargo Bank Northwest, National Association, as Owner Trustee*
(aimee.b.johnson@wellsfargo.com)
Creditor: National City Bank* (luci.johnson@pnc.com)
Right to Discharge Holder: PNC Bank, National Association (luci.johnson@pnc.com)

Transfer of Right to Discharge

Date/Time	Transferor	Transferee
18 Sep 2015 20:11:58 GMT	National City Bank*	PNC Bank, National Association

16 Mar 2009 15:17:52 GMT

File Number: 321887

Registration

Type: Sale
Fractional or Partial Interest: 100.000000%
Seller: CFM International, Inc. (stephen.graves@ge.com)
Buyer: Wells Fargo Bank Northwest, National Association, as Owner Trustee*
(aimee.b.johnson@wellsfargo.com)

07 Jul 2009 20:59:08 GMT

File Number: 345143

Registration

Type: International Interest
Fractional or Partial Interest: 100.000000%
Debtor: American Airlines, Inc. (geraldine.lim@aa.com)
Creditor: Wells Fargo Bank Northwest, National Association, as Owner Trustee*
(aimee.b.johnson@wellsfargo.com)
Right to Discharge Holder: Wells Fargo Trust Company, National Association, as Owner Trustee*
(aimee.b.johnson@wellsfargo.com)

07 Jul 2009 21:05:26 GMT

File Number: 345145

Registration

Type: Assignment of an International Interest
Interest being Assigned: 345143
Fractional or Partial Interest: 100.000000%
Assignor: Wells Fargo Bank Northwest, National Association, as Owner Trustee*
 (aimee.b.johnson@wellsfargo.com)
Assignee: National City Bank* (luci.johnson@pnc.com)
Right to Discharge Holder: PNC Bank, National Association (luci.johnson@pnc.com)

Transfer of Right to Discharge

Date/Time	Transferor	Transferee
18 Sep 2015 20:11:58 GMT	National City Bank*	PNC Bank, National Association

22 Oct 2009 18:35:55 GMT

File Number: 21904

Registration

Type: International Interest
Fractional or Partial Interest: 100.000000%
Debtor: American Airlines, Inc. (geraldine.lim@aa.com)
Creditor: Wells Fargo Bank Northwest, National Association, as Owner Trustee*
 (aimee.b.johnson@wellsfargo.com)
Right to Discharge Holder: Wells Fargo Trust Company, National Association, as Owner Trustee*
 (aimee.b.johnson@wellsfargo.com)

22 Oct 2009 19:47:58 GMT

File Number: 21926

Registration

Type: Assignment of an International Interest
Interest being Assigned: 21904
Fractional or Partial Interest: 100.000000%
Assignor: Wells Fargo Bank Northwest, National Association, as Owner Trustee*
 (aimee.b.johnson@wellsfargo.com)
Assignee: National City Bank* (luci.johnson@pnc.com)
Right to Discharge Holder: PNC Bank, National Association (luci.johnson@pnc.com)

Transfer of Right to Discharge

Date/Time	Transferor	Transferee
18 Sep 2015 20:11:58 GMT	National City Bank*	PNC Bank, National Association

18 Nov 2009 21:37:25 GMT

File Number: 31232

Registration

Type: International Interest
Fractional or Partial Interest: 100.000000%
Debtor: Wells Fargo Bank Northwest, National Association, as Owner Trustee*
 (aimee.b.johnson@wellsfargo.com)
Creditor: Union Bank, N.A.* (Terumi.Nishi@unionbank.com)
Right to Discharge Holder: MUFG Union Bank, N.A.* (Terumi.Nishi@unionbank.com)

20 Nov 2009 20:38:46 GMT		File Number: 32142
Discharge	Type:	International Interest
	Discharge of File:	321885
	Fractional or Partial Interest:	100.000000%
	Remaining Interest:	0.000000%
	Date of Discharge:	20 Nov 2009
	Debtor:	Wells Fargo Bank Northwest, National Association, as Owner Trustee* (aimee.b.johnson@wellsfargo.com)
	Creditor:	National City Bank* (luci.johnson@pnc.com)

20 Nov 2009 20:40:21 GMT		File Number: 32152
Discharge	Type:	Assignment of an International Interest
	Discharge of File:	345145
	Fractional or Partial Interest:	100.000000%
	Remaining Interest:	0.000000%
	Date of Discharge:	20 Nov 2009
	Assignor:	Wells Fargo Bank Northwest, National Association, as Owner Trustee* (aimee.b.johnson@wellsfargo.com)
	Assignee:	National City Bank* (luci.johnson@pnc.com)

20 Nov 2009 20:41:45 GMT		File Number: 32156
Discharge	Type:	Assignment of an International Interest
	Discharge of File:	21926
	Fractional or Partial Interest:	100.000000%
	Remaining Interest:	0.000000%
	Date of Discharge:	20 Nov 2009
	Assignor:	Wells Fargo Bank Northwest, National Association, as Owner Trustee* (aimee.b.johnson@wellsfargo.com)
	Assignee:	National City Bank* (luci.johnson@pnc.com)

20 Nov 2009 20:45:11 GMT		File Number: 32158
Registration	Type:	Assignment of an International Interest
	Interest being Assigned:	345143
	Fractional or Partial Interest:	100.000000%
	Assignor:	Wells Fargo Bank Northwest, National Association, as Owner Trustee* (aimee.b.johnson@wellsfargo.com)
	Assignee:	Union Bank, N.A.* (Terumi.Nishi@unionbank.com)
	Right to Discharge Holder:	MUFG Union Bank, N.A.* (Terumi.Nishi@unionbank.com)

20 Nov 2009 20:46:34 GMT		File Number: 32160
Registration	Type:	Assignment of an International Interest
	Interest being Assigned:	21904
	Fractional or Partial Interest:	100.000000%
	Assignor:	Wells Fargo Bank Northwest, National Association, as Owner Trustee* (aimee.b.johnson@wellsfargo.com)
	Assignee:	Union Bank, N.A.* (Terumi.Nishi@unionbank.com)
	Right to Discharge Holder:	MUFG Union Bank, N.A.* (Terumi.Nishi@unionbank.com)

29 Dec 2009 20:06:40 GMT		File Number: 40780
Registration	Type:	International Interest
	Fractional or Partial Interest:	100.000000%
	Debtor:	American Airlines, Inc. (geraldine.lim@aa.com)
	Creditor:	Wells Fargo Bank Northwest, National Association, as Owner Trustee* (aimee.b.johnson@wellsfargo.com)
	Right to Discharge Holder:	Wells Fargo Trust Company, National Association, as Owner Trustee* (aimee.b.johnson@wellsfargo.com)

29 Dec 2009 20:22:13 GMT		File Number: 40794
Registration	Type:	Assignment of an International Interest
	Interest being Assigned:	40780
	Fractional or Partial Interest:	100.000000%
	Assignor:	Wells Fargo Bank Northwest, National Association, as Owner Trustee* (aimee.b.johnson@wellsfargo.com)
	Assignee:	Union Bank, N.A.* (Terumi.Nishi@unionbank.com)
	Right to Discharge Holder:	MUFG Union Bank, N.A.* (Terumi.Nishi@unionbank.com)

20 Jan 2010 21:02:04 GMT		File Number: 46696
Discharge	Type:	International Interest
	Discharge of File:	31232
	Fractional or Partial Interest:	100.000000%
	Remaining Interest:	0.000000%
	Date of Discharge:	20 Jan 2010
	Debtor:	Wells Fargo Bank Northwest, National Association, as Owner Trustee* (aimee.b.johnson@wellsfargo.com)
	Creditor:	Union Bank, N.A.* (Terumi.Nishi@unionbank.com)

20 Jan 2010 21:03:28 GMT		File Number: 46698
Discharge	Type:	Assignment of an International Interest
	Discharge of File:	32158
	Fractional or Partial Interest:	100.000000%
	Remaining Interest:	0.000000%
	Date of Discharge:	20 Jan 2010
	Assignor:	Wells Fargo Bank Northwest, National Association, as Owner Trustee* (aimee.b.johnson@wellsfargo.com)
	Assignee:	Union Bank, N.A.* (Terumi.Nishi@unionbank.com)

20 Jan 2010 21:04:52 GMT		File Number: 46700
Discharge	Type:	Assignment of an International Interest
	Discharge of File:	32160
	Fractional or Partial Interest:	100.000000%
	Remaining Interest:	0.000000%
	Date of Discharge:	20 Jan 2010
	Assignor:	Wells Fargo Bank Northwest, National Association, as Owner Trustee* (aimee.b.johnson@wellsfargo.com)
	Assignee:	Union Bank, N.A.* (Terumi.Nishi@unionbank.com)

20 Jan 2010 21:06:20 GMT		File Number: 46704
Discharge	Type:	Assignment of an International Interest
	Discharge of File:	40794
	Fractional or Partial Interest:	100.000000%
	Remaining Interest:	0.000000%
	Date of Discharge:	20 Jan 2010
	Assignor:	Wells Fargo Bank Northwest, National Association, as Owner Trustee* (aimee.b.johnson@wellsfargo.com)
	Assignee:	Union Bank, N.A.* (Terumi.Nishi@unionbank.com)

20 Jan 2010 21:21:01 GMT		File Number: 46728
Registration	Type:	International Interest
	Fractional or Partial Interest:	100.000000%
	Debtor:	Wells Fargo Bank Northwest, National Association, as Owner Trustee* (aimee.b.johnson@wellsfargo.com)
	Creditor:	Deutsche Bank Trust Company Americas (louis.bodi@db.com)
	Right to Discharge Holder:	Deutsche Bank Trust Company Americas (louis.bodi@db.com)

20 Jan 2010 21:22:32 GMT		File Number: 46736
Registration	Type:	Assignment of an International Interest
	Interest being Assigned:	345143
	Fractional or Partial Interest:	100.000000%
	Assignor:	Wells Fargo Bank Northwest, National Association, as Owner Trustee* (aimee.b.johnson@wellsfargo.com)
	Assignee:	Deutsche Bank Trust Company Americas (louis.bodi@db.com)
Right to Discharge Holder:	Deutsche Bank Trust Company Americas (louis.bodi@db.com)	

20 Jan 2010 21:24:13 GMT		File Number: 46742
Registration	Type:	Assignment of an International Interest
	Interest being Assigned:	21904
	Fractional or Partial Interest:	100.000000%
	Assignor:	Wells Fargo Bank Northwest, National Association, as Owner Trustee* (aimee.b.johnson@wellsfargo.com)
	Assignee:	Deutsche Bank Trust Company Americas (louis.bodi@db.com)
Right to Discharge Holder:	Deutsche Bank Trust Company Americas (louis.bodi@db.com)	

20 Jan 2010 21:25:41 GMT		File Number: 46746
Registration	Type:	Assignment of an International Interest
	Interest being Assigned:	40780
	Fractional or Partial Interest:	100.000000%
	Assignor:	Wells Fargo Bank Northwest, National Association, as Owner Trustee* (aimee.b.johnson@wellsfargo.com)
	Assignee:	Deutsche Bank Trust Company Americas (louis.bodi@db.com)
Right to Discharge Holder:	Deutsche Bank Trust Company Americas (louis.bodi@db.com)	

13 Apr 2010 18:23:05 GMT		File Number: 55464
Registration	Type:	International Interest
	Fractional or Partial Interest:	100.000000%
	Debtor:	American Airlines, Inc. (geraldine.lim@aa.com)
	Creditor:	Wells Fargo Bank Northwest, National Association, as Owner Trustee* (aimee.b.johnson@wellsfargo.com)
	Right to Discharge Holder:	Wells Fargo Trust Company, National Association, as Owner Trustee* (aimee.b.johnson@wellsfargo.com)

13 Apr 2010 18:48:43 GMT

File Number: 55498

Registration

Type: Assignment of an International Interest
Interest being Assigned: 55464
Fractional or Partial Interest: 100.000000%
Assignor: Wells Fargo Bank Northwest, National Association, as Owner Trustee*
 (aimee.b.johnson@wellsfargo.com)
Assignee: Deutsche Bank Trust Company Americas (louis.bodi@db.com)
Right to Discharge Holder: Deutsche Bank Trust Company Americas (louis.bodi@db.com)

04 Aug 2010 17:41:53 GMT

File Number: 90754

Discharge

Type: International Interest
Discharge of File: 345143
Fractional or Partial Interest: 100.000000%
Remaining Interest: 0.000000%
Date of Discharge: 04 Aug 2010
Debtor: American Airlines, Inc. (geraldine.lim@aa.com)
Creditor: Wells Fargo Bank Northwest, National Association, as Owner Trustee*
 (aimee.b.johnson@wellsfargo.com)

04 Aug 2010 17:43:18 GMT

File Number: 90756

Discharge

Type: Assignment of an International Interest
Discharge of File: 46736
Fractional or Partial Interest: 100.000000%
Remaining Interest: 0.000000%
Date of Discharge: 04 Aug 2010
Assignor: Wells Fargo Bank Northwest, National Association, as Owner Trustee*
 (aimee.b.johnson@wellsfargo.com)
Assignee: Deutsche Bank Trust Company Americas (louis.bodi@db.com)

04 Aug 2010 17:46:11 GMT

File Number: 90760

Discharge

Type: International Interest
Discharge of File: 21904
Fractional or Partial Interest: 100.000000%
Remaining Interest: 0.000000%
Date of Discharge: 04 Aug 2010
Debtor: American Airlines, Inc. (geraldine.lim@aa.com)
Creditor: Wells Fargo Bank Northwest, National Association, as Owner Trustee*
 (aimee.b.johnson@wellsfargo.com)

04 Aug 2010 17:47:40 GMT

File Number: 90764

Discharge

Type: Assignment of an International Interest
Discharge of File: 46742
Fractional or Partial Interest: 100.000000%
Remaining Interest: 0.000000%
Date of Discharge: 04 Aug 2010
Assignor: Wells Fargo Bank Northwest, National Association, as Owner Trustee*
 (aimee.b.johnson@wellsfargo.com)
Assignee: Deutsche Bank Trust Company Americas (louis.bodi@db.com)

04 Aug 2010 17:50:06 GMT		File Number: 90766
Discharge	Type:	International Interest
	Discharge of File:	40780
	Fractional or Partial Interest:	100.000000%
	Remaining Interest:	0.000000%
	Date of Discharge:	04 Aug 2010
	Debtor:	American Airlines, Inc. (geraldine.lim@aa.com)
	Creditor:	Wells Fargo Bank Northwest, National Association, as Owner Trustee* (aimee.b.johnson@wellsfargo.com)
04 Aug 2010 17:51:35 GMT		File Number: 90768
Discharge	Type:	Assignment of an International Interest
	Discharge of File:	46746
	Fractional or Partial Interest:	100.000000%
	Remaining Interest:	0.000000%
	Date of Discharge:	04 Aug 2010
	Assignor:	Wells Fargo Bank Northwest, National Association, as Owner Trustee* (aimee.b.johnson@wellsfargo.com)
Assignee:	Deutsche Bank Trust Company Americas (louis.bodi@db.com)	
04 Aug 2010 17:53:15 GMT		File Number: 90772
Discharge	Type:	International Interest
	Discharge of File:	55464
	Fractional or Partial Interest:	100.000000%
	Remaining Interest:	0.000000%
	Date of Discharge:	04 Aug 2010
	Debtor:	American Airlines, Inc. (geraldine.lim@aa.com)
	Creditor:	Wells Fargo Bank Northwest, National Association, as Owner Trustee* (aimee.b.johnson@wellsfargo.com)
04 Aug 2010 17:55:48 GMT		File Number: 90774
Discharge	Type:	Assignment of an International Interest
	Discharge of File:	55498
	Fractional or Partial Interest:	100.000000%
	Remaining Interest:	0.000000%
	Date of Discharge:	04 Aug 2010
	Assignor:	Wells Fargo Bank Northwest, National Association, as Owner Trustee* (aimee.b.johnson@wellsfargo.com)
Assignee:	Deutsche Bank Trust Company Americas (louis.bodi@db.com)	
28 Sep 2010 18:01:15 GMT		File Number: 648838
Registration	Type:	International Interest
	Fractional or Partial Interest:	100.000000%
	Debtor:	WEST ENGINE FUNDING (IRELAND) LIMITED (dskinner@willislease.com)
	Creditor:	Wells Fargo Bank Northwest, National Association, as Owner Trustee* (aimee.b.johnson@wellsfargo.com)
	Right to Discharge Holder:	Wells Fargo Trust Company, National Association, as Owner Trustee* (aimee.b.johnson@wellsfargo.com)

28 Sep 2010 18:05:39 GMT		File Number: 648844
Registration	Type:	Assignment of an International Interest
	Interest being Assigned:	648838
	Fractional or Partial Interest:	100.000000%
	Assignor:	Wells Fargo Bank Northwest, National Association, as Owner Trustee* (aimee.b.johnson@wellsfargo.com)
	Assignee:	Deutsche Bank Trust Company Americas (louis.bodi@db.com)
	Right to Discharge Holder:	Deutsche Bank Trust Company Americas (louis.bodi@db.com)

07 Apr 2011 15:30:10 GMT		File Number: 696656
Registration	Type:	International Interest
	Fractional or Partial Interest:	100.000000%
	Debtor:	WEST ENGINE FUNDING (IRELAND) LIMITED (dskinner@willislease.com)
	Creditor:	Wells Fargo Bank Northwest, National Association, as Owner Trustee* (aimee.b.johnson@wellsfargo.com)
	Right to Discharge Holder:	Wells Fargo Trust Company, National Association, as Owner Trustee* (aimee.b.johnson@wellsfargo.com)

07 Apr 2011 15:32:58 GMT		File Number: 696660
Registration	Type:	Assignment of an International Interest
	Interest being Assigned:	696656
	Fractional or Partial Interest:	100.000000%
	Assignor:	Wells Fargo Bank Northwest, National Association, as Owner Trustee* (aimee.b.johnson@wellsfargo.com)
	Assignee:	Deutsche Bank Trust Company Americas (louis.bodi@db.com)
	Right to Discharge Holder:	Deutsche Bank Trust Company Americas (louis.bodi@db.com)

20 Jul 2011 21:04:58 GMT		File Number: 731378
Discharge	Type:	International Interest
	Discharge of File:	696656
	Fractional or Partial Interest:	100.000000%
	Remaining Interest:	0.000000%
	Date of Discharge:	20 Jul 2011
	Debtor:	WEST ENGINE FUNDING (IRELAND) LIMITED (dskinner@willislease.com)
	Creditor:	Wells Fargo Bank Northwest, National Association, as Owner Trustee* (aimee.b.johnson@wellsfargo.com)

20 Jul 2011 21:06:35 GMT		File Number: 731380
Discharge	Type:	Assignment of an International Interest
	Discharge of File:	696660
	Fractional or Partial Interest:	100.000000%
	Remaining Interest:	0.000000%
	Date of Discharge:	20 Jul 2011
	Assignor:	Wells Fargo Bank Northwest, National Association, as Owner Trustee* (aimee.b.johnson@wellsfargo.com)
	Assignee:	Deutsche Bank Trust Company Americas (louis.bodi@db.com)

20 Jul 2011 21:08:17 GMT		File Number: 731382
Discharge	Type:	International Interest
	Discharge of File:	648838
	Fractional or Partial Interest:	100.000000%
	Remaining Interest:	0.000000%
	Date of Discharge:	20 Jul 2011
	Debtor:	WEST ENGINE FUNDING (IRELAND) LIMITED (dskinner@willislease.com)
	Creditor:	Wells Fargo Bank Northwest, National Association, as Owner Trustee* (aimee.b.johnson@wellsfargo.com)
20 Jul 2011 21:10:10 GMT		File Number: 731384
Discharge	Type:	Assignment of an International Interest
	Discharge of File:	648844
	Fractional or Partial Interest:	100.000000%
	Remaining Interest:	0.000000%
	Date of Discharge:	20 Jul 2011
	Assignor:	Wells Fargo Bank Northwest, National Association, as Owner Trustee* (aimee.b.johnson@wellsfargo.com)
	Assignee:	Deutsche Bank Trust Company Americas (louis.bodi@db.com)
26 Sep 2012 15:47:46 GMT		File Number: 886400
Discharge	Type:	International Interest
	Discharge of File:	46728
	Fractional or Partial Interest:	100.000000%
	Remaining Interest:	0.000000%
	Date of Discharge:	26 Sep 2012
	Debtor:	Wells Fargo Bank Northwest, National Association, as Owner Trustee* (aimee.b.johnson@wellsfargo.com)
	Creditor:	Deutsche Bank Trust Company Americas (louis.bodi@db.com)
26 Sep 2012 15:52:48 GMT		File Number: 886406
Registration	Type:	International Interest
	Fractional or Partial Interest:	100.000000%
	Debtor:	Wells Fargo Bank Northwest, National Association, as Owner Trustee* (aimee.b.johnson@wellsfargo.com)
	Creditor:	Union Bank, N.A.* (Terumi.Nishi@unionbank.com)
	Right to Discharge Holder:	MUFG Union Bank, N.A.* (Terumi.Nishi@unionbank.com)
07 Jun 2013 17:53:32 GMT		File Number: 993168
Registration	Type:	International Interest
	Fractional or Partial Interest:	100.000000%
	Debtor:	Alaska Airlines, Inc. (laura.murray@alaskaair.com)
	Creditor:	Wells Fargo Bank Northwest, National Association, as Owner Trustee* (aimee.b.johnson@wellsfargo.com)
	Right to Discharge Holder:	Wells Fargo Trust Company, National Association, as Owner Trustee* (aimee.b.johnson@wellsfargo.com)
07 Jun 2013 18:10:05 GMT		File Number: 993174
Registration	Type:	Assignment of an International Interest
	Interest being Assigned:	993168
	Fractional or Partial Interest:	100.000000%
	Assignor:	Wells Fargo Bank Northwest, National Association, as Owner Trustee* (aimee.b.johnson@wellsfargo.com)
	Assignee:	Union Bank, N.A.* (Terumi.Nishi@unionbank.com)
Right to Discharge Holder:	MUFG Union Bank, N.A.* (Terumi.Nishi@unionbank.com)	

23 Aug 2013 18:17:06 GMT		File Number: 1023814
Registration	Type:	International Interest
	Fractional or Partial Interest:	100.000000%
	Debtor:	Alaska Airlines, Inc. (laura.murray@alaskaair.com)
	Creditor:	Wells Fargo Bank Northwest, National Association, as Owner Trustee* (aimee.b.johnson@wellsfargo.com)
	Right to Discharge Holder:	Wells Fargo Trust Company, National Association, as Owner Trustee* (aimee.b.johnson@wellsfargo.com)

23 Aug 2013 18:24:31 GMT		File Number: 1023816
Registration	Type:	Assignment of an International Interest
	Interest being Assigned:	1023814
	Fractional or Partial Interest:	100.000000%
	Assignor:	Wells Fargo Bank Northwest, National Association, as Owner Trustee* (aimee.b.johnson@wellsfargo.com)
	Assignee:	Union Bank, N.A.* (Terumi.Nishi@unionbank.com)
	Right to Discharge Holder:	MUFG Union Bank, N.A.* (Terumi.Nishi@unionbank.com)

13 Mar 2014 21:41:01 GMT		File Number: 1075666
Discharge	Type:	International Interest
	Discharge of File:	993168
	Fractional or Partial Interest:	100.000000%
	Remaining Interest:	0.000000%
	Date of Discharge:	13 Mar 2014
	Debtor:	Alaska Airlines, Inc. (laura.murray@alaskaair.com)
	Creditor:	Wells Fargo Bank Northwest, National Association, as Owner Trustee* (aimee.b.johnson@wellsfargo.com)

13 Mar 2014 21:42:01 GMT		File Number: 1075667
Discharge	Type:	Assignment of an International Interest
	Discharge of File:	993174
	Fractional or Partial Interest:	100.000000%
	Remaining Interest:	0.000000%
	Date of Discharge:	13 Mar 2014
	Assignor:	Wells Fargo Bank Northwest, National Association, as Owner Trustee* (aimee.b.johnson@wellsfargo.com)
	Assignee:	Union Bank, N.A.* (Terumi.Nishi@unionbank.com)

13 Mar 2014 21:43:01 GMT		File Number: 1075668
Discharge	Type:	International Interest
	Discharge of File:	1023814
	Fractional or Partial Interest:	100.000000%
	Remaining Interest:	0.000000%
	Date of Discharge:	13 Mar 2014
	Debtor:	Alaska Airlines, Inc. (laura.murray@alaskaair.com)
	Creditor:	Wells Fargo Bank Northwest, National Association, as Owner Trustee* (aimee.b.johnson@wellsfargo.com)

13 Mar 2014 21:43:02 GMT

File Number: 1075669

Discharge

Type: Assignment of an International Interest
Discharge of File: 1023816
Fractional or Partial Interest: 100.000000%
Remaining Interest: 0.000000%
Date of Discharge: 13 Mar 2014
Assignor: Wells Fargo Bank Northwest, National Association, as Owner Trustee*
 (aimee.b.johnson@wellsfargo.com)
Assignee: Union Bank, N.A.* (Terumi.Nishi@unionbank.com)

19 Mar 2014 15:44:01 GMT

File Number: 1076587

Registration

Type: International Interest
Fractional or Partial Interest: 100.000000%
Debtor: I.M.P. Group Limited (rick.benwell@impgroup.com)
Creditor: Wells Fargo Bank Northwest, National Association, as Owner Trustee*
 (aimee.b.johnson@wellsfargo.com)
Right to Discharge Holder: Wells Fargo Trust Company, National Association, as Owner Trustee*
 (aimee.b.johnson@wellsfargo.com)

19 Mar 2014 15:47:01 GMT

File Number: 1076588

Registration

Type: Assignment of an International Interest
Interest being Assigned: 1076587
Fractional or Partial Interest: 100.000000%
Assignor: Wells Fargo Bank Northwest, National Association, as Owner Trustee*
 (aimee.b.johnson@wellsfargo.com)
Assignee: Union Bank, N.A.* (Terumi.Nishi@unionbank.com)
Right to Discharge Holder: MUFG Union Bank, N.A.* (Terumi.Nishi@unionbank.com)

20 May 2014 14:19:02 GMT

File Number: 1093052

Registration

Type: International Interest
Fractional or Partial Interest: 100.000000%
Debtor: Delta Air Lines, Inc. (kathleen.r.radde@delta.com)
Creditor: Wells Fargo Bank Northwest, National Association, as Owner Trustee*
 (aimee.b.johnson@wellsfargo.com)
Right to Discharge Holder: Deutsche Bank Trust Company Americas (louis.bodi@db.com)

Transfer of Right to Discharge

Date/Time	Transferor	Transferee
25 Sep 2017 18:59:59 GMT	Wells Fargo Bank Northwest, National Association, as Owner Trustee*	Deutsche Bank Trust Company Americas

20 May 2014 14:27:02 GMT

File Number: 1093056

Registration

Type: Assignment of an International Interest
Interest being Assigned: 1093052
Fractional or Partial Interest: 100.000000%
Assignor: Wells Fargo Bank Northwest, National Association, as Owner Trustee*
 (aimee.b.johnson@wellsfargo.com)
Assignee: Union Bank, N.A.* (Terumi.Nishi@unionbank.com)
Right to Discharge Holder: MUFG Union Bank, N.A.* (Terumi.Nishi@unionbank.com)

20 May 2014 16:44:03 GMT		File Number: 1093168
Discharge	Type:	International Interest
	Discharge of File:	1076587
	Fractional or Partial Interest:	100.000000%
	Remaining Interest:	0.000000%
	Date of Discharge:	20 May 2014
	Debtor:	I.M.P. Group Limited (rick.benwell@impgroup.com)
	Creditor:	Wells Fargo Bank Northwest, National Association, as Owner Trustee* (aimee.b.johnson@wellsfargo.com)
20 May 2014 16:44:06 GMT		File Number: 1093169
Discharge	Type:	Assignment of an International Interest
	Discharge of File:	1076588
	Fractional or Partial Interest:	100.000000%
	Remaining Interest:	0.000000%
	Date of Discharge:	20 May 2014
	Assignor:	Wells Fargo Bank Northwest, National Association, as Owner Trustee* (aimee.b.johnson@wellsfargo.com)
	Assignee:	Union Bank, N.A.* (Terumi.Nishi@unionbank.com)
09 Jun 2014 22:03:42 GMT		File Number: 1099458
Registration	Type:	International Interest
	Fractional or Partial Interest:	100.000000%
	Debtor:	Wells Fargo Bank Northwest, National Association, as Owner Trustee* (aimee.b.johnson@wellsfargo.com)
	Creditor:	Union Bank, N.A.* (Terumi.Nishi@unionbank.com)
	Right to Discharge Holder:	MUFG Union Bank, N.A.* (Terumi.Nishi@unionbank.com)
11 Aug 2014 14:31:02 GMT		File Number: 1113909
Registration	Type:	International Interest
	Fractional or Partial Interest:	100.000000%
	Debtor:	Delta Air Lines, Inc. (kathleen.r.radde@delta.com)
	Creditor:	Wells Fargo Bank Northwest, National Association, as Owner Trustee* (aimee.b.johnson@wellsfargo.com)
Right to Discharge Holder:	Wells Fargo Trust Company, National Association, as Owner Trustee* (aimee.b.johnson@wellsfargo.com)	
11 Aug 2014 14:44:02 GMT		File Number: 1113920
Registration	Type:	Assignment of an International Interest
	Interest being Assigned:	1113909
	Fractional or Partial Interest:	100.000000%
	Assignor:	Wells Fargo Bank Northwest, National Association, as Owner Trustee* (aimee.b.johnson@wellsfargo.com)
	Assignee:	Union Bank, N.A.* (Terumi.Nishi@unionbank.com)
Right to Discharge Holder:	MUFG Union Bank, N.A.* (Terumi.Nishi@unionbank.com)	
25 Sep 2014 14:25:03 GMT		File Number: 1123535
Registration	Type:	International Interest
	Fractional or Partial Interest:	100.000000%
	Debtor:	Delta Air Lines, Inc. (kathleen.r.radde@delta.com)
	Creditor:	Wells Fargo Bank Northwest, National Association, as Owner Trustee* (aimee.b.johnson@wellsfargo.com)
	Right to Discharge Holder:	Wells Fargo Trust Company, National Association, as Owner Trustee* (aimee.b.johnson@wellsfargo.com)

25 Sep 2014 15:01:05 GMT		File Number: 1123544
Registration	Type:	Assignment of an International Interest
	Interest being Assigned:	1123535
	Fractional or Partial Interest:	100.000000%
	Assignor:	Wells Fargo Bank Northwest, National Association, as Owner Trustee* (aimee.b.johnson@wellsfargo.com)
	Assignee:	Union Bank, N.A.* (Terumi.Nishi@unionbank.com)
	Right to Discharge Holder:	MUFG Union Bank, N.A.* (Terumi.Nishi@unionbank.com)
11 Feb 2015 22:32:04 GMT		File Number: 1161648
Discharge	Type:	International Interest
	Discharge of File:	1113909
	Fractional or Partial Interest:	100.000000%
	Remaining Interest:	0.000000%
	Date of Discharge:	11 Feb 2015
	Debtor:	Delta Air Lines, Inc. (kathleen.r.radde@delta.com)
Creditor:	Wells Fargo Bank Northwest, National Association, as Owner Trustee* (aimee.b.johnson@wellsfargo.com)	
11 Feb 2015 22:33:03 GMT		File Number: 1161649
Discharge	Type:	Assignment of an International Interest
	Discharge of File:	1113920
	Fractional or Partial Interest:	100.000000%
	Remaining Interest:	0.000000%
	Date of Discharge:	11 Feb 2015
	Assignor:	Wells Fargo Bank Northwest, National Association, as Owner Trustee* (aimee.b.johnson@wellsfargo.com)
Assignee:	MUFG Union Bank, N.A.* (Terumi.Nishi@unionbank.com)	
11 Feb 2015 22:34:03 GMT		File Number: 1161650
Discharge	Type:	International Interest
	Discharge of File:	1123535
	Fractional or Partial Interest:	100.000000%
	Remaining Interest:	0.000000%
	Date of Discharge:	11 Feb 2015
	Debtor:	Delta Air Lines, Inc. (kathleen.r.radde@delta.com)
Creditor:	Wells Fargo Bank Northwest, National Association, as Owner Trustee* (aimee.b.johnson@wellsfargo.com)	
11 Feb 2015 22:34:06 GMT		File Number: 1161651
Discharge	Type:	Assignment of an International Interest
	Discharge of File:	1123544
	Fractional or Partial Interest:	100.000000%
	Remaining Interest:	0.000000%
	Date of Discharge:	11 Feb 2015
	Assignor:	Wells Fargo Bank Northwest, National Association, as Owner Trustee* (aimee.b.johnson@wellsfargo.com)
Assignee:	MUFG Union Bank, N.A.* (Terumi.Nishi@unionbank.com)	

10 Apr 2015 19:18:06 GMT		File Number: 1176802	
Registration	Type:	International Interest	
	Fractional or Partial Interest:	100.000000%	
	Debtor:	I.M.P. Group Limited (rick.benwell@impgroup.com)	
	Creditor:	Wells Fargo Bank Northwest, National Association, as Owner Trustee* (aimee.b.johnson@wellsfargo.com)	
	Right to Discharge Holder:	Wells Fargo Trust Company, National Association, as Owner Trustee* (aimee.b.johnson@wellsfargo.com)	
10 Apr 2015 19:20:05 GMT		File Number: 1176805	
Registration	Type:	Assignment of an International Interest	
	Interest being Assigned:	1176802	
	Fractional or Partial Interest:	100.000000%	
	Assignor:	Wells Fargo Bank Northwest, National Association, as Owner Trustee* (aimee.b.johnson@wellsfargo.com)	
	Assignee:	MUFG Union Bank, N.A.* (Terumi.Nishi@unionbank.com)	
Right to Discharge Holder:	MUFG Union Bank, N.A.* (Terumi.Nishi@unionbank.com)		
10 Sep 2015 21:20:05 GMT		File Number: 1216715	
Registration	Type:	International Interest	
	Fractional or Partial Interest:	100.000000%	
	Debtor:	I.M.P. Group Limited (rick.benwell@impgroup.com)	
	Creditor:	Wells Fargo Bank Northwest, National Association, as Owner Trustee* (aimee.b.johnson@wellsfargo.com)	
	Right to Discharge Holder:	Wells Fargo Trust Company, National Association, as Owner Trustee* (aimee.b.johnson@wellsfargo.com)	
10 Sep 2015 21:25:01 GMT		File Number: 1216719	
Registration	Type:	Assignment of an International Interest	
	Interest being Assigned:	1216715	
	Fractional or Partial Interest:	100.000000%	
	Assignor:	Wells Fargo Bank Northwest, National Association, as Owner Trustee* (aimee.b.johnson@wellsfargo.com)	
	Assignee:	MUFG Union Bank, N.A.* (Terumi.Nishi@unionbank.com)	
Right to Discharge Holder:	MUFG Union Bank, N.A.* (Terumi.Nishi@unionbank.com)		
21 Dec 2015 16:34:05 GMT		File Number: 1246706	
Registration	Type:	International Interest	
	Fractional or Partial Interest:	100.000000%	
	Debtor:	Delta Air Lines, Inc. (kathleen.r.radde@delta.com)	
	Creditor:	Wells Fargo Bank Northwest, National Association, as Owner Trustee* (aimee.b.johnson@wellsfargo.com)	
	Right to Discharge Holder:	Deutsche Bank Trust Company Americas (louis.bodi@db.com)	
Registration	Transfer of Right to Discharge		
	Date/Time	Transferor	Transferee
	25 Sep 2017 19:00:02 GMT	Wells Fargo Bank Northwest, National Association, as Owner Trustee*	Deutsche Bank Trust Company Americas

21 Dec 2015 16:42:01 GMT		File Number: 1246719
Registration	Type:	Assignment of an International Interest
	Interest being Assigned:	1246706
	Fractional or Partial Interest:	100.000000%
	Assignor:	Wells Fargo Bank Northwest, National Association, as Owner Trustee* (aimee.b.johnson@wellsfargo.com)
	Assignee:	MUFG Union Bank, N.A.* (Terumi.Nishi@unionbank.com)
	Right to Discharge Holder:	MUFG Union Bank, N.A.* (Terumi.Nishi@unionbank.com)
06 Jan 2016 21:52:07 GMT		File Number: 1253481
Discharge	Type:	International Interest
	Discharge of File:	1176802
	Fractional or Partial Interest:	100.000000%
	Remaining Interest:	0.000000%
	Date of Discharge:	06 Jan 2016
	Debtor:	I.M.P. Group Limited (rick.benwell@impgroup.com)
	Creditor:	Wells Fargo Bank Northwest, National Association, as Owner Trustee* (aimee.b.johnson@wellsfargo.com)
06 Jan 2016 21:55:01 GMT		File Number: 1253483
Discharge	Type:	Assignment of an International Interest
	Discharge of File:	1176805
	Fractional or Partial Interest:	100.000000%
	Remaining Interest:	0.000000%
	Date of Discharge:	06 Jan 2016
	Assignor:	Wells Fargo Bank Northwest, National Association, as Owner Trustee* (aimee.b.johnson@wellsfargo.com)
	Assignee:	MUFG Union Bank, N.A.* (Terumi.Nishi@unionbank.com)
06 Jan 2016 21:56:01 GMT		File Number: 1253484
Discharge	Type:	International Interest
	Discharge of File:	1216715
	Fractional or Partial Interest:	100.000000%
	Remaining Interest:	0.000000%
	Date of Discharge:	06 Jan 2016
	Debtor:	I.M.P. Group Limited (rick.benwell@impgroup.com)
	Creditor:	Wells Fargo Bank Northwest, National Association, as Owner Trustee* (aimee.b.johnson@wellsfargo.com)
06 Jan 2016 21:57:01 GMT		File Number: 1253485
Discharge	Type:	Assignment of an International Interest
	Discharge of File:	1216719
	Fractional or Partial Interest:	100.000000%
	Remaining Interest:	0.000000%
	Date of Discharge:	06 Jan 2016
	Assignor:	Wells Fargo Bank Northwest, National Association, as Owner Trustee* (aimee.b.johnson@wellsfargo.com)
	Assignee:	MUFG Union Bank, N.A.* (Terumi.Nishi@unionbank.com)

21 Apr 2016 14:23:45 GMT		File Number: 1280125
Registration	Type:	International Interest
	Fractional or Partial Interest:	100.000000%
	Debtor:	Wells Fargo Bank Northwest, National Association, as Owner Trustee* (aimee.b.johnson@wellsfargo.com)
	Creditor:	MUFG Union Bank, N.A.* (Terumi.Nishi@unionbank.com)
	Right to Discharge Holder:	MUFG Union Bank, N.A.* (Terumi.Nishi@unionbank.com)

04 Jan 2017 15:32:06 GMT		File Number: 1357834						
Registration	Type:	International Interest						
	Fractional or Partial Interest:	100.000000%						
	Debtor:	Delta Air Lines, Inc. (kathleen.r.radde@delta.com)						
	Creditor:	Wells Fargo Bank Northwest, National Association, as Owner Trustee* (aimee.b.johnson@wellsfargo.com)						
	Right to Discharge Holder:	Deutsche Bank Trust Company Americas (louis.bodi@db.com)						
Transfer of Right to Discharge								
<table border="1"> <thead> <tr> <th>Date/Time</th> <th>Transferor</th> <th>Transferee</th> </tr> </thead> <tbody> <tr> <td>25 Sep 2017 19:00:05 GMT</td> <td>Wells Fargo Bank Northwest, National Association, as Owner Trustee*</td> <td>Deutsche Bank Trust Company Americas</td> </tr> </tbody> </table>			Date/Time	Transferor	Transferee	25 Sep 2017 19:00:05 GMT	Wells Fargo Bank Northwest, National Association, as Owner Trustee*	Deutsche Bank Trust Company Americas
Date/Time	Transferor	Transferee						
25 Sep 2017 19:00:05 GMT	Wells Fargo Bank Northwest, National Association, as Owner Trustee*	Deutsche Bank Trust Company Americas						

04 Jan 2017 15:51:04 GMT		File Number: 1357845
Registration	Type:	Assignment of an International Interest
	Interest being Assigned:	1357834
	Fractional or Partial Interest:	100.000000%
	Assignor:	Wells Fargo Bank Northwest, National Association, as Owner Trustee* (aimee.b.johnson@wellsfargo.com)
	Assignee:	MUFG Union Bank, N.A.* (Terumi.Nishi@unionbank.com)
Right to Discharge Holder:	MUFG Union Bank, N.A.* (Terumi.Nishi@unionbank.com)	

15 Sep 2017 18:23:01 GMT		File Number: 1433324
Discharge	Type:	International Interest
	Discharge of File:	886406
	Fractional or Partial Interest:	100.000000%
	Remaining Interest:	0.000000%
	Date of Discharge:	15 Sep 2017
	Debtor:	Wells Fargo Bank Northwest, National Association, as Owner Trustee* (aimee.b.johnson@wellsfargo.com)
	Creditor:	MUFG Union Bank, N.A.* (Terumi.Nishi@unionbank.com)

15 Sep 2017 18:23:04 GMT		File Number: 1433325
Discharge	Type:	Assignment of an International Interest
	Discharge of File:	1093056
	Fractional or Partial Interest:	100.000000%
	Remaining Interest:	0.000000%
	Date of Discharge:	15 Sep 2017
	Assignor:	Wells Fargo Bank Northwest, National Association, as Owner Trustee* (aimee.b.johnson@wellsfargo.com)
	Assignee:	MUFG Union Bank, N.A.* (Terumi.Nishi@unionbank.com)

15 Sep 2017 18:23:08 GMT		File Number: 1433326
Discharge	Type:	International Interest
	Discharge of File:	1099458
	Fractional or Partial Interest:	100.000000%
	Remaining Interest:	0.000000%
	Date of Discharge:	15 Sep 2017
	Debtor:	Wells Fargo Bank Northwest, National Association, as Owner Trustee* (aimee.b.johnson@wellsfargo.com)
	Creditor:	MUFG Union Bank, N.A.* (Terumi.Nishi@unionbank.com)
15 Sep 2017 18:23:11 GMT		File Number: 1433327
Discharge	Type:	Assignment of an International Interest
	Discharge of File:	1246719
	Fractional or Partial Interest:	100.000000%
	Remaining Interest:	0.000000%
	Date of Discharge:	15 Sep 2017
	Assignor:	Wells Fargo Bank Northwest, National Association, as Owner Trustee* (aimee.b.johnson@wellsfargo.com)
	Assignee:	MUFG Union Bank, N.A.* (Terumi.Nishi@unionbank.com)
15 Sep 2017 18:23:15 GMT		File Number: 1433328
Discharge	Type:	International Interest
	Discharge of File:	1280125
	Fractional or Partial Interest:	100.000000%
	Remaining Interest:	0.000000%
	Date of Discharge:	15 Sep 2017
	Debtor:	Wells Fargo Bank Northwest, National Association, as Owner Trustee* (aimee.b.johnson@wellsfargo.com)
	Creditor:	MUFG Union Bank, N.A.* (Terumi.Nishi@unionbank.com)
15 Sep 2017 18:23:18 GMT		File Number: 1433329
Discharge	Type:	Assignment of an International Interest
	Discharge of File:	1357845
	Fractional or Partial Interest:	100.000000%
	Remaining Interest:	0.000000%
	Date of Discharge:	15 Sep 2017
	Assignor:	Wells Fargo Bank Northwest, National Association, as Owner Trustee* (aimee.b.johnson@wellsfargo.com)
	Assignee:	MUFG Union Bank, N.A.* (Terumi.Nishi@unionbank.com)
15 Sep 2017 18:23:22 GMT		File Number: 1433330
Registration	Type:	International Interest
	Fractional or Partial Interest:	100.000000%
	Debtor:	Wells Fargo Bank Northwest, National Association, as Owner Trustee* (aimee.b.johnson@wellsfargo.com)
	Creditor:	Deutsche Bank Trust Company Americas (louis.bodi@db.com)
	Right to Discharge Holder:	Deutsche Bank Trust Company Americas (louis.bodi@db.com)

15 Sep 2017 18:23:25 GMT		File Number: 1433331
Registration	Type:	Assignment of an International Interest
	Interest being Assigned:	1093052
	Fractional or Partial Interest:	100.000000%
	Assignor:	Wells Fargo Bank Northwest, National Association, as Owner Trustee* (aimee.b.johnson@wellsfargo.com)
	Assignee:	Deutsche Bank Trust Company Americas (louis.bodi@db.com)
	Right to Discharge Holder:	Deutsche Bank Trust Company Americas (louis.bodi@db.com)

15 Sep 2017 18:23:28 GMT		File Number: 1433332
Registration	Type:	Assignment of an International Interest
	Interest being Assigned:	1246706
	Fractional or Partial Interest:	100.000000%
	Assignor:	Wells Fargo Bank Northwest, National Association, as Owner Trustee* (aimee.b.johnson@wellsfargo.com)
	Assignee:	Deutsche Bank Trust Company Americas (louis.bodi@db.com)
	Right to Discharge Holder:	Deutsche Bank Trust Company Americas (louis.bodi@db.com)

15 Sep 2017 18:23:31 GMT		File Number: 1433333
Registration	Type:	Assignment of an International Interest
	Interest being Assigned:	1357834
	Fractional or Partial Interest:	100.000000%
	Assignor:	Wells Fargo Bank Northwest, National Association, as Owner Trustee* (aimee.b.johnson@wellsfargo.com)
	Assignee:	Deutsche Bank Trust Company Americas (louis.bodi@db.com)
	Right to Discharge Holder:	Deutsche Bank Trust Company Americas (louis.bodi@db.com)

18 Jan 2018 20:58:01 GMT		File Number: 1477627
Discharge	Type:	International Interest
	Discharge of File:	1093052
	Fractional or Partial Interest:	100.000000%
	Remaining Interest:	0.000000%
	Date of Discharge:	18 Jan 2018
	Debtor:	Delta Air Lines, Inc. (kathleen.r.radde@delta.com)
	Creditor:	Wells Fargo Bank Northwest, National Association, as Owner Trustee* (aimee.b.johnson@wellsfargo.com)

18 Jan 2018 21:00:01 GMT		File Number: 1477628
Discharge	Type:	International Interest
	Discharge of File:	1246706
	Fractional or Partial Interest:	100.000000%
	Remaining Interest:	0.000000%
	Date of Discharge:	18 Jan 2018
	Debtor:	Delta Air Lines, Inc. (kathleen.r.radde@delta.com)
	Creditor:	Wells Fargo Bank Northwest, National Association, as Owner Trustee* (aimee.b.johnson@wellsfargo.com)

18 Jan 2018 21:01:01 GMT		File Number: 1477629
Discharge	Type:	International Interest
	Discharge of File:	1357834
	Fractional or Partial Interest:	100.000000%
	Remaining Interest:	0.000000%
	Date of Discharge:	18 Jan 2018
	Debtor:	Delta Air Lines, Inc. (kathleen.r.radde@delta.com)
	Creditor:	Wells Fargo Bank Northwest, National Association, as Owner Trustee* (aimee.b.johnson@wellsfargo.com)

18 Jan 2018 21:02:01 GMT		File Number: 1477630
Discharge	Type:	Assignment of an International Interest
	Discharge of File:	1433331
	Fractional or Partial Interest:	100.000000%
	Remaining Interest:	0.000000%
	Date of Discharge:	18 Jan 2018
	Assignor:	Wells Fargo Bank Northwest, National Association, as Owner Trustee* (aimee.b.johnson@wellsfargo.com)
	Assignee:	Deutsche Bank Trust Company Americas (louis.bodi@db.com)

18 Jan 2018 21:03:01 GMT		File Number: 1477631
Discharge	Type:	Assignment of an International Interest
	Discharge of File:	1433332
	Fractional or Partial Interest:	100.000000%
	Remaining Interest:	0.000000%
	Date of Discharge:	18 Jan 2018
	Assignor:	Wells Fargo Bank Northwest, National Association, as Owner Trustee* (aimee.b.johnson@wellsfargo.com)
	Assignee:	Deutsche Bank Trust Company Americas (louis.bodi@db.com)

18 Jan 2018 21:03:04 GMT		File Number: 1477632
Discharge	Type:	Assignment of an International Interest
	Discharge of File:	1433333
	Fractional or Partial Interest:	100.000000%
	Remaining Interest:	0.000000%
	Date of Discharge:	18 Jan 2018
	Assignor:	Wells Fargo Bank Northwest, National Association, as Owner Trustee* (aimee.b.johnson@wellsfargo.com)
	Assignee:	Deutsche Bank Trust Company Americas (louis.bodi@db.com)

21 Feb 2018 16:02:01 GMT		File Number: 1486035	
Registration	Type:	International Interest	
	Fractional or Partial Interest:	100.000000%	
	Debtor:	Southwest Airlines Co. (irclosings@gilchristaviation.com)	
	Creditor:	Wells Fargo Bank Northwest, National Association, as Owner Trustee* (aimee.b.johnson@wellsfargo.com)	
	Right to Discharge Holder:	Deutsche Bank Trust Company Americas (louis.bodi@db.com)	
Transfer of Right to Discharge			
	Date/Time	Transferor	Transferee
	21 Feb 2018 16:18:01 GMT	Wells Fargo Bank Northwest, National Association, as Owner Trustee*	Deutsche Bank Trust Company Americas

21 Feb 2018 16:17:01 GMT		File Number: 1486036
Registration	Type:	Assignment of an International Interest
	Interest being Assigned:	1486035
	Fractional or Partial Interest:	100.000000%
	Assignor:	Wells Fargo Bank Northwest, National Association, as Owner Trustee* (aimee.b.johnson@wellsfargo.com)
	Assignee:	Deutsche Bank Trust Company Americas (louis.bodi@db.com)
	Right to Discharge Holder:	Deutsche Bank Trust Company Americas (louis.bodi@db.com)

24 Jun 2019 20:18:01 GMT		File Number: 1648717	
Registration	Type:	International Interest	
	Fractional or Partial Interest:	100.000000%	
	Debtor:	VB Leaseco Pty Ltd (billy.mayberry@virginaustralia.com)	
	Creditor:	Wells Fargo Trust Company, National Association, as Owner Trustee* (aimee.b.johnson@wellsfargo.com)	
	Right to Discharge Holder:	Deutsche Bank Trust Company Americas (louis.bodi@db.com)	
Transfer of Right to Discharge			
	Date/Time	Transferor	Transferee
	24 Jun 2019 20:18:08 GMT	Wells Fargo Trust Company, National Association, as Owner Trustee*	Deutsche Bank Trust Company Americas

24 Jun 2019 20:18:04 GMT		File Number: 1648718
Registration	Type:	Assignment of an International Interest
	Interest being Assigned:	1648717
	Fractional or Partial Interest:	100.000000%
	Assignor:	Wells Fargo Trust Company, National Association, as Owner Trustee* (aimee.b.johnson@wellsfargo.com)
	Assignee:	Deutsche Bank Trust Company Americas (louis.bodi@db.com)
	Right to Discharge Holder:	Deutsche Bank Trust Company Americas (louis.bodi@db.com)

24 Jun 2019 20:18:12 GMT		File Number: 1648719	
Registration	Type:	International Interest	
	Fractional or Partial Interest:	100.000000%	
	Debtor:	Virgin Australia Airlines Pty Limited* (billy.mayberry@virginaustralia.com)	
	Creditor:	VB Leaseco Pty Ltd (billy.mayberry@virginaustralia.com)	
	Right to Discharge Holder:	Deutsche Bank Trust Company Americas (louis.bodi@db.com)	
Transfer of Right to Discharge			
	Date/Time	Transferor	Transferee
	24 Jun 2019 20:18:16 GMT	VB Leaseco Pty Ltd	Deutsche Bank Trust Company Americas

24 Jun 2019 20:18:20 GMT		File Number: 1648720
Registration	Type:	Assignment of an International Interest
	Interest being Assigned:	1648719
	Fractional or Partial Interest:	100.000000%
	Assignor:	VB Leaseco Pty Ltd (billy.mayberry@virginaustralia.com)
	Assignee:	Wells Fargo Trust Company, National Association, as Owner Trustee* (aimee.b.johnson@wellsfargo.com)
	Right to Discharge Holder:	Deutsche Bank Trust Company Americas (louis.bodi@db.com)
Transfer of Right to Discharge		
	Date/Time	Transferor
	24 Jun 2019 20:18:23 GMT	Wells Fargo Trust Company, National Association, as Owner Trustee*
		Transferee
		Deutsche Bank Trust Company Americas

24 Jun 2019 20:18:28 GMT		File Number: 1648721
Registration	Type:	Assignment of an International Interest
	Interest being Assigned:	1648720
	Fractional or Partial Interest:	100.000000%
	Assignor:	Wells Fargo Trust Company, National Association, as Owner Trustee* (aimee.b.johnson@wellsfargo.com)
	Assignee:	Deutsche Bank Trust Company Americas (louis.bodi@db.com)
	Right to Discharge Holder:	Deutsche Bank Trust Company Americas (louis.bodi@db.com)

12 Jul 2019 19:14:32 GMT		File Number: 1656474
Discharge	Type:	International Interest
	Discharge of File:	1486035
	Fractional or Partial Interest:	100.000000%
	Remaining Interest:	0.000000%
	Date of Discharge:	12 Jul 2019
	Debtor:	Southwest Airlines Co. (irclosings@gilchristaviation.com)
	Creditor:	Wells Fargo Trust Company, National Association, as Owner Trustee* (aimee.b.johnson@wellsfargo.com)

12 Jul 2019 19:14:36 GMT		File Number: 1656475
Discharge	Type:	Assignment of an International Interest
	Discharge of File:	1486036
	Fractional or Partial Interest:	100.000000%
	Remaining Interest:	0.000000%
	Date of Discharge:	12 Jul 2019
	Assignor:	Wells Fargo Trust Company, National Association, as Owner Trustee* (aimee.b.johnson@wellsfargo.com)
	Assignee:	Deutsche Bank Trust Company Americas (louis.bodi@db.com)

End of List

In conformity with Article 22(3) of the Cape Town Convention "international interest" in this certificate denotes an interest which the creditor has acquired or intends to acquire and is not intended to indicate whether what is registered is an international interest or a prospective international interest. Similarly, with reference to Article 19(4) and 19(5) of the Cape Town Convention, "assignment" is not intended to indicate whether what is registered is an assignment or a prospective assignment, and, in conformity with Article III of the Aircraft Protocol, "sale" is not intended to indicate whether what is registered is a sale or a prospective sale.

The International Registry system is designed to use percentages with a maximum of six decimal places when recording fractional and partial interests in aircraft objects e.g. 12.123456%. Please consider that certain fractions cannot be fully represented within six decimal places. Percentages shown are of the full aircraft object.

*The International Registry was notified that this entity had a change of name within the meaning set out in the Regulations and Procedures for the International Registry.

Name Change History			
Entity Reference	Old Name	New Name	Date Changed on International Registry
0000007508	National City Bank	PNC Bank, National Association	18-Sep-2015
0000044112	Wells Fargo Bank Northwest, National Association, as Owner Trustee	Wells Fargo Trust Company, National Association, as Owner Trustee	04-May-2018
0000011534	Union Bank, N.A.	MUFG Union Bank, N.A.	17-Nov-2014
0000011534	Union Bank of California, N.A.	Union Bank, N.A.	22-Jul-2009
0214802006	Virgin Blue Airlines Pty Limited	Virgin Australia Airlines Pty Limited	11-May-2011

Supplementary Priority Search Information

This information table contains supplementary priority search information provided pursuant to Section 7.8 of the Regulations for the International Registry. Supplementary priority search information is provided for information purposes only to assist users in reviewing the registered information contained in the priority search certificate. **Users must review all registered information contained in the priority search certificate and not just the information contained in the supplementary priority search information.** In the case of inconsistency between the registered information contained in the priority search certificate and the supplementary priority search information, the registered information contained in the priority search certificate shall prevail. Any such inconsistency and any inaccuracy discovered should be reported to the Registrar within 72 hours of receipt of the priority search certificate by the user.

Date	Type	File Number	Fractional or Partial Interest	Fully Discharged	Discharged by File Number(s)	Date of Full Discharge
16 Mar 2009 15:15:33 GMT	International Interest	321885__	100.000000%	YES	32142	20 Nov 2009
16 Mar 2009 15:17:52 GMT	Sale	321887__	100.000000%	-	-	-
07 Jul 2009 20:59:08 GMT	International Interest	345143__	100.000000%	YES	90754	04 Aug 2010
07 Jul 2009 21:05:26 GMT	Assignment of an International Interest	345145__	100.000000%	YES	32152	20 Nov 2009
22 Oct 2009 18:35:55 GMT	International Interest	21904__	100.000000%	YES	90760	04 Aug 2010
22 Oct 2009 19:47:58 GMT	Assignment of an International Interest	21926__	100.000000%	YES	32156	20 Nov 2009
18 Nov 2009 21:37:25 GMT	International Interest	31232__	100.000000%	YES	46696	20 Jan 2010
20 Nov 2009 20:45:11 GMT	Assignment of an International Interest	32158__	100.000000%	YES	46698	20 Jan 2010
20 Nov 2009 20:46:34 GMT	Assignment of an International Interest	32160__	100.000000%	YES	46700	20 Jan 2010
29 Dec 2009 20:06:40 GMT	International Interest	40780__	100.000000%	YES	90766	04 Aug 2010
29 Dec 2009 20:22:13 GMT	Assignment of an International Interest	40794__	100.000000%	YES	46704	20 Jan 2010
20 Jan 2010 21:21:01 GMT	International Interest	46728__	100.000000%	YES	886400	26 Sep 2012
20 Jan 2010 21:22:32 GMT	Assignment of an International Interest	46736__	100.000000%	YES	90756	04 Aug 2010
20 Jan 2010 21:24:13 GMT	Assignment of an International Interest	46742__	100.000000%	YES	90764	04 Aug 2010

Supplementary Priority Search Information

Date	Type	File Number	Fractional or Partial Interest	Fully Discharged	Discharged by File Number(s)	Date of Full Discharge
20 Jan 2010 21:25:41 GMT	Assignment of an International Interest	46746...	100.000000%	YES	90768	04 Aug 2010
13 Apr 2010 18:23:05 GMT	International Interest	55464...	100.000000%	YES	90772	04 Aug 2010
13 Apr 2010 18:48:43 GMT	Assignment of an International Interest	55498...	100.000000%	YES	90774	04 Aug 2010
28 Sep 2010 18:01:15 GMT	International Interest	648838...	100.000000%	YES	731382	20 Jul 2011
28 Sep 2010 18:05:39 GMT	Assignment of an International Interest	648844...	100.000000%	YES	731384	20 Jul 2011
07 Apr 2011 15:30:10 GMT	International Interest	696656...	100.000000%	YES	731378	20 Jul 2011
07 Apr 2011 15:32:58 GMT	Assignment of an International Interest	696660...	100.000000%	YES	731380	20 Jul 2011
26 Sep 2012 15:52:48 GMT	International Interest	886406...	100.000000%	YES	1433324	15 Sep 2017
07 Jun 2013 17:53:32 GMT	International Interest	993168...	100.000000%	YES	1075666	13 Mar 2014
07 Jun 2013 18:10:05 GMT	Assignment of an International Interest	993174...	100.000000%	YES	1075667	13 Mar 2014
23 Aug 2013 18:17:06 GMT	International Interest	1023814...	100.000000%	YES	1075668	13 Mar 2014
23 Aug 2013 18:24:31 GMT	Assignment of an International Interest	1023816...	100.000000%	YES	1075669	13 Mar 2014
19 Mar 2014 15:44:01 GMT	International Interest	1076587...	100.000000%	YES	1093168	20 May 2014
19 Mar 2014 15:47:01 GMT	Assignment of an International Interest	1076588...	100.000000%	YES	1093169	20 May 2014
20 May 2014 14:19:02 GMT	International Interest	1093052...	100.000000%	YES	1477627	18 Jan 2018
20 May 2014 14:27:02 GMT	Assignment of an International Interest	1093056...	100.000000%	YES	1433325	15 Sep 2017

Supplementary Priority Search Information

Date	Type	File Number	Fractional or Partial Interest	Fully Discharged	Discharged by File Number(s)	Date of Full Discharge
09 Jun 2014 22:03:42 GMT	International Interest	1099458	100.000000%	YES	1433326	15 Sep 2017
11 Aug 2014 14:31:02 GMT	International Interest	1113909	100.000000%	YES	1161648	11 Feb 2015
11 Aug 2014 14:44:02 GMT	Assignment of an International Interest	1113920	100.000000%	YES	1161649	11 Feb 2015
25 Sep 2014 14:25:03 GMT	International Interest	1123535	100.000000%	YES	1161650	11 Feb 2015
25 Sep 2014 15:01:05 GMT	Assignment of an International Interest	1123544	100.000000%	YES	1161651	11 Feb 2015
10 Apr 2015 19:18:06 GMT	International Interest	1176802	100.000000%	YES	1253481	06 Jan 2016
10 Apr 2015 19:20:05 GMT	Assignment of an International Interest	1176805	100.000000%	YES	1253483	06 Jan 2016
10 Sep 2015 21:20:05 GMT	International Interest	1216715	100.000000%	YES	1253484	06 Jan 2016
10 Sep 2015 21:25:01 GMT	Assignment of an International Interest	1216719	100.000000%	YES	1253485	06 Jan 2016
21 Dec 2015 16:34:05 GMT	International Interest	1246706	100.000000%	YES	1477628	18 Jan 2018
21 Dec 2015 16:42:01 GMT	Assignment of an International Interest	1246719	100.000000%	YES	1433327	15 Sep 2017
21 Apr 2016 14:23:45 GMT	International Interest	1280125	100.000000%	YES	1433328	15 Sep 2017
04 Jan 2017 15:32:06 GMT	International Interest	1357834	100.000000%	YES	1477629	18 Jan 2018
04 Jan 2017 15:51:04 GMT	Assignment of an International Interest	1357845	100.000000%	YES	1433329	15 Sep 2017
15 Sep 2017 18:23:22 GMT	International Interest	1433330	100.000000%	-	-	-
15 Sep 2017 18:23:25 GMT	Assignment of an International Interest	1433331	100.000000%	YES	1477630	18 Jan 2018

Supplementary Priority Search Information						
Date	Type	File Number	Fractional or Partial Interest	Fully Discharged	Discharged by File Number(s)	Date of Full Discharge
15 Sep 2017 18:23:28 GMT	Assignment of an International Interest	1433332	100.000000%	YES	1477631	18 Jan 2018
15 Sep 2017 18:23:31 GMT	Assignment of an International Interest	1433333	100.000000%	YES	1477632	18 Jan 2018
21 Feb 2018 16:02:01 GMT	International Interest	1486035	100.000000%	YES	1656474	12 Jul 2019
21 Feb 2018 16:17:01 GMT	Assignment of an International Interest	1486036	100.000000%	YES	1656475	12 Jul 2019
24 Jun 2019 20:18:01 GMT	International Interest	1648717	100.000000%	-	-	-
24 Jun 2019 20:18:04 GMT	Assignment of an International Interest	1648718	100.000000%	-	-	-
24 Jun 2019 20:18:12 GMT	International Interest	1648719	100.000000%	-	-	-
24 Jun 2019 20:18:20 GMT	Assignment of an International Interest	1648720	100.000000%	-	-	-
24 Jun 2019 20:18:28 GMT	Assignment of an International Interest	1648721	100.000000%	-	-	-

PRIORITY SEARCH CERTIFICATE

Issued by the International Registry of International Interests in Aircraft Equipment

Certificate Number

1360022

This certificate was created on 06 May 2020 at 22:56:15 GMT

Requested by: Ashleigh Taylor-reeve

Beneficiary of Priority Search Certificate: InfoTrack

Search Criteria

Manufacturer: CFM
Model Designation: CFM56-7
Manufacturer's Serial Number: 894902

31 Aug 2007 00:20:18 GMT

File Number: 168297

Registration

Fractional or Partial Interest: **Type:** Sale
100.000000%
Seller: CFM International, Inc. (stephen.graves@ge.com)
Buyer: International Lease Finance Corporation (ctconvention@aercap.com)

22 Dec 2014 21:08:04 GMT

File Number: 1149212

Registration

Fractional or Partial Interest: **Type:** International Interest
100.000000%
Debtor: Wells Fargo Bank Northwest, National Association, as Owner Trustee*
(aimee.b.johnson@wellsfargo.com)
Creditor: MUFG Union Bank, N.A.* (Terumi.Nishi@unionbank.com)
Right to Discharge Holder: MUFG Union Bank, N.A.* (Terumi.Nishi@unionbank.com)

22 Dec 2014 22:19:07 GMT

File Number: 1149311

Registration

Fractional or Partial Interest: **Type:** Sale
100.000000%
Seller: Pratt & Whitney Engine Leasing, LLC (irdfphj222@dfph.com)
Buyer: Wells Fargo Bank Northwest, National Association, as Owner Trustee*
(aimee.b.johnson@wellsfargo.com)

22 Dec 2014 22:39:02 GMT

File Number: 1149351

Registration

Fractional or Partial Interest: **Type:** International Interest
100.000000%
Debtor: Joint Stock Company "Orenburg Airlines" (karavaytseva@orenair.ru)
Creditor: Wells Fargo Bank Northwest, National Association, as Owner Trustee*
(aimee.b.johnson@wellsfargo.com)
Right to Discharge Holder: Wells Fargo Trust Company, National Association, as Owner Trustee*
(aimee.b.johnson@wellsfargo.com)

22 Dec 2014 22:43:04 GMT

File Number: 1149361

Registration

Interest being Assigned: **Type:** Assignment of an International Interest
1149351
Fractional or Partial Interest: 100.000000%
Assignor: Wells Fargo Bank Northwest, National Association, as Owner Trustee*
(aimee.b.johnson@wellsfargo.com)
Assignee: MUFG Union Bank, N.A.* (Terumi.Nishi@unionbank.com)
Right to Discharge Holder: MUFG Union Bank, N.A.* (Terumi.Nishi@unionbank.com)

29 Jan 2015 17:56:02 GMT		File Number: 1157989
Registration	Type:	International Interest
	Fractional or Partial Interest:	100.000000%
	Debtor:	Joint Stock Company "Orenburg Airlines" (karavaytseva@orenair.ru)
	Creditor:	Wells Fargo Bank Northwest, National Association, as Owner Trustee* (aimee.b.johnson@wellsfargo.com)
	Right to Discharge Holder:	Wells Fargo Trust Company, National Association, as Owner Trustee* (aimee.b.johnson@wellsfargo.com)
29 Jan 2015 18:02:02 GMT		File Number: 1158005
Registration	Type:	Assignment of an International Interest
	Interest being Assigned:	1157989
	Fractional or Partial Interest:	100.000000%
	Assignor:	Wells Fargo Bank Northwest, National Association, as Owner Trustee* (aimee.b.johnson@wellsfargo.com)
	Assignee:	MUFG Union Bank, N.A.* (Terumi.Nishi@unionbank.com)
Right to Discharge Holder:	MUFG Union Bank, N.A.* (Terumi.Nishi@unionbank.com)	
31 Mar 2015 21:04:06 GMT		File Number: 1174419
Registration	Type:	International Interest
	Fractional or Partial Interest:	100.000000%
	Debtor:	Joint Stock Company "Orenburg Airlines" (karavaytseva@orenair.ru)
	Creditor:	Wells Fargo Bank Northwest, National Association, as Owner Trustee* (aimee.b.johnson@wellsfargo.com)
	Right to Discharge Holder:	Wells Fargo Trust Company, National Association, as Owner Trustee* (aimee.b.johnson@wellsfargo.com)
31 Mar 2015 21:08:08 GMT		File Number: 1174427
Registration	Type:	Assignment of an International Interest
	Interest being Assigned:	1174419
	Fractional or Partial Interest:	100.000000%
	Assignor:	Wells Fargo Bank Northwest, National Association, as Owner Trustee* (aimee.b.johnson@wellsfargo.com)
	Assignee:	MUFG Union Bank, N.A.* (Terumi.Nishi@unionbank.com)
Right to Discharge Holder:	MUFG Union Bank, N.A.* (Terumi.Nishi@unionbank.com)	
02 Oct 2015 17:18:02 GMT		File Number: 1224613
Discharge	Type:	International Interest
	Discharge of File:	1149351
	Fractional or Partial Interest:	100.000000%
	Remaining Interest:	0.000000%
	Date of Discharge:	02 Oct 2015
	Debtor:	Joint Stock Company "Orenburg Airlines" (karavaytseva@orenair.ru)
	Creditor:	Wells Fargo Bank Northwest, National Association, as Owner Trustee* (aimee.b.johnson@wellsfargo.com)
02 Oct 2015 17:20:05 GMT		File Number: 1224614
Discharge	Type:	Assignment of an International Interest
	Discharge of File:	1149361
	Fractional or Partial Interest:	100.000000%
	Remaining Interest:	0.000000%
	Date of Discharge:	02 Oct 2015
	Assignor:	Wells Fargo Bank Northwest, National Association, as Owner Trustee* (aimee.b.johnson@wellsfargo.com)
	Assignee:	MUFG Union Bank, N.A.* (Terumi.Nishi@unionbank.com)

02 Oct 2015 17:21:01 GMT		File Number: 1224615
Discharge	Type:	International Interest
	Discharge of File:	1157989
	Fractional or Partial Interest:	100.000000%
	Remaining Interest:	0.000000%
	Date of Discharge:	02 Oct 2015
	Debtor:	Joint Stock Company "Orenburg Airlines" (karavaytseva@orenair.ru)
	Creditor:	Wells Fargo Bank Northwest, National Association, as Owner Trustee* (aimee.b.johnson@wellsfargo.com)
02 Oct 2015 17:22:01 GMT		File Number: 1224616
Discharge	Type:	Assignment of an International Interest
	Discharge of File:	1158005
	Fractional or Partial Interest:	100.000000%
	Remaining Interest:	0.000000%
	Date of Discharge:	02 Oct 2015
	Assignor:	Wells Fargo Bank Northwest, National Association, as Owner Trustee* (aimee.b.johnson@wellsfargo.com)
Assignee:	MUFG Union Bank, N.A.* (Terumi.Nishi@unionbank.com)	
02 Oct 2015 17:23:01 GMT		File Number: 1224617
Discharge	Type:	International Interest
	Discharge of File:	1174419
	Fractional or Partial Interest:	100.000000%
	Remaining Interest:	0.000000%
	Date of Discharge:	02 Oct 2015
	Debtor:	Joint Stock Company "Orenburg Airlines" (karavaytseva@orenair.ru)
	Creditor:	Wells Fargo Bank Northwest, National Association, as Owner Trustee* (aimee.b.johnson@wellsfargo.com)
02 Oct 2015 17:23:02 GMT		File Number: 1224618
Discharge	Type:	Assignment of an International Interest
	Discharge of File:	1174427
	Fractional or Partial Interest:	100.000000%
	Remaining Interest:	0.000000%
	Date of Discharge:	02 Oct 2015
	Assignor:	Wells Fargo Bank Northwest, National Association, as Owner Trustee* (aimee.b.johnson@wellsfargo.com)
Assignee:	MUFG Union Bank, N.A.* (Terumi.Nishi@unionbank.com)	
07 Jan 2016 18:40:12 GMT		File Number: 1253674
Registration	Type:	International Interest
	Fractional or Partial Interest:	100.000000%
	Debtor:	TRANSAVIA FRANCE (nathalie.stubler@fr.transavia.com)
	Creditor:	Wells Fargo Bank Northwest, National Association, as Owner Trustee* (aimee.b.johnson@wellsfargo.com)
	Right to Discharge Holder:	Wells Fargo Trust Company, National Association, as Owner Trustee* (aimee.b.johnson@wellsfargo.com)

07 Jan 2016 18:45:04 GMT		File Number: 1253677
Registration	Type:	Assignment of an International Interest
	Interest being Assigned:	1253674
	Fractional or Partial Interest:	100.000000%
	Assignor:	Wells Fargo Bank Northwest, National Association, as Owner Trustee* (aimee.b.johnson@wellsfargo.com)
	Assignee:	MUFG Union Bank, N.A.* (Terumi.Nishi@unionbank.com)
	Right to Discharge Holder:	MUFG Union Bank, N.A.* (Terumi.Nishi@unionbank.com)
21 Apr 2016 14:23:20 GMT		File Number: 1280117
Registration	Type:	International Interest
	Fractional or Partial Interest:	100.000000%
	Debtor:	Wells Fargo Bank Northwest, National Association, as Owner Trustee* (aimee.b.johnson@wellsfargo.com)
	Creditor:	MUFG Union Bank, N.A.* (Terumi.Nishi@unionbank.com)
	Right to Discharge Holder:	MUFG Union Bank, N.A.* (Terumi.Nishi@unionbank.com)
10 Aug 2016 14:52:01 GMT		File Number: 1311765
Discharge	Type:	International Interest
	Discharge of File:	1253674
	Fractional or Partial Interest:	100.000000%
	Remaining Interest:	0.000000%
	Date of Discharge:	10 Aug 2016
	Debtor:	TRANSAVIA FRANCE (nathalie.stubler@fr.transavia.com)
	Creditor:	Wells Fargo Bank Northwest, National Association, as Owner Trustee* (aimee.b.johnson@wellsfargo.com)
10 Aug 2016 14:53:01 GMT		File Number: 1311766
Discharge	Type:	Assignment of an International Interest
	Discharge of File:	1253677
	Fractional or Partial Interest:	100.000000%
	Remaining Interest:	0.000000%
	Date of Discharge:	10 Aug 2016
	Assignor:	Wells Fargo Bank Northwest, National Association, as Owner Trustee* (aimee.b.johnson@wellsfargo.com)
	Assignee:	MUFG Union Bank, N.A.* (Terumi.Nishi@unionbank.com)
27 Sep 2017 19:52:01 GMT		File Number: 1438962
Discharge	Type:	International Interest
	Discharge of File:	1149212
	Fractional or Partial Interest:	100.000000%
	Remaining Interest:	0.000000%
	Date of Discharge:	27 Sep 2017
	Debtor:	Wells Fargo Bank Northwest, National Association, as Owner Trustee* (aimee.b.johnson@wellsfargo.com)
	Creditor:	MUFG Union Bank, N.A.* (Terumi.Nishi@unionbank.com)

27 Sep 2017 19:52:05 GMT		File Number: 1438963
Discharge	Type:	International Interest
	Discharge of File:	1280117
	Fractional or Partial Interest:	100.000000%
	Remaining Interest:	0.000000%
	Date of Discharge:	27 Sep 2017
	Debtor:	Wells Fargo Bank Northwest, National Association, as Owner Trustee* (aimee.b.johnson@wellsfargo.com)
	Creditor:	MUFG Union Bank, N.A.* (Terumi.Nishi@unionbank.com)

27 Sep 2017 19:52:08 GMT		File Number: 1438964
Registration	Type:	International Interest
	Fractional or Partial Interest:	100.000000%
	Debtor:	Wells Fargo Bank Northwest, National Association, as Owner Trustee* (aimee.b.johnson@wellsfargo.com)
	Creditor:	Deutsche Bank Trust Company Americas (louis.bodi@db.com)
	Right to Discharge Holder:	Deutsche Bank Trust Company Americas (louis.bodi@db.com)

13 Sep 2019 18:32:01 GMT		File Number: 1676734						
Registration	Type:	International Interest						
	Fractional or Partial Interest:	100.000000%						
	Debtor:	VB Leaseco Pty Ltd (billy.mayberry@virginaustralia.com)						
	Creditor:	Wells Fargo Trust Company, National Association, as Owner Trustee* (aimee.b.johnson@wellsfargo.com)						
	Right to Discharge Holder:	Deutsche Bank Trust Company Americas (louis.bodi@db.com)						
Transfer of Right to Discharge								
<table border="1"> <thead> <tr> <th>Date/Time</th> <th>Transferor</th> <th>Transferee</th> </tr> </thead> <tbody> <tr> <td>13 Sep 2019 18:32:24 GMT</td> <td>Wells Fargo Trust Company, National Association, as Owner Trustee*</td> <td>Deutsche Bank Trust Company Americas</td> </tr> </tbody> </table>			Date/Time	Transferor	Transferee	13 Sep 2019 18:32:24 GMT	Wells Fargo Trust Company, National Association, as Owner Trustee*	Deutsche Bank Trust Company Americas
Date/Time	Transferor	Transferee						
13 Sep 2019 18:32:24 GMT	Wells Fargo Trust Company, National Association, as Owner Trustee*	Deutsche Bank Trust Company Americas						

13 Sep 2019 18:32:05 GMT		File Number: 1676735
Registration	Type:	Assignment of an International Interest
	Interest being Assigned:	1676734
	Fractional or Partial Interest:	100.000000%
	Assignor:	Wells Fargo Trust Company, National Association, as Owner Trustee* (aimee.b.johnson@wellsfargo.com)
	Assignee:	Deutsche Bank Trust Company Americas (louis.bodi@db.com)
Right to Discharge Holder:	Deutsche Bank Trust Company Americas (louis.bodi@db.com)	

13 Sep 2019 18:32:11 GMT		File Number: 1676736	
Registration	Type:	International Interest	
	Fractional or Partial Interest:	100.000000%	
	Debtor:	Virgin Australia Airlines Pty Limited* (billy.mayberry@virginaustralia.com)	
	Creditor:	VB Leaseco Pty Ltd (billy.mayberry@virginaustralia.com)	
	Right to Discharge Holder:	Deutsche Bank Trust Company Americas (louis.bodi@db.com)	
Transfer of Right to Discharge			
	Date/Time	Transferor	Transferee
	13 Sep 2019 18:32:33 GMT	VB Leaseco Pty Ltd	Deutsche Bank Trust Company Americas

13 Sep 2019 18:32:15 GMT		File Number: 1676737	
Registration	Type:	Assignment of an International Interest	
	Interest being Assigned:	1676736	
	Fractional or Partial Interest:	100.000000%	
	Assignor:	VB Leaseco Pty Ltd (billy.mayberry@virginaustralia.com)	
	Assignee:	Wells Fargo Trust Company, National Association, as Owner Trustee* (aimee.b.johnson@wellsfargo.com)	
Right to Discharge Holder:	Deutsche Bank Trust Company Americas (louis.bodi@db.com)		
Transfer of Right to Discharge			
	Date/Time	Transferor	Transferee
	13 Sep 2019 18:32:29 GMT	Wells Fargo Trust Company, National Association, as Owner Trustee*	Deutsche Bank Trust Company Americas

13 Sep 2019 18:32:20 GMT		File Number: 1676738
Registration	Type:	Assignment of an International Interest
	Interest being Assigned:	1676737
	Fractional or Partial Interest:	100.000000%
	Assignor:	Wells Fargo Trust Company, National Association, as Owner Trustee* (aimee.b.johnson@wellsfargo.com)
	Assignee:	Deutsche Bank Trust Company Americas (louis.bodi@db.com)
Right to Discharge Holder:	Deutsche Bank Trust Company Americas (louis.bodi@db.com)	

End of List

In conformity with Article 22(3) of the Cape Town Convention "international interest" in this certificate denotes an interest which the creditor has acquired or intends to acquire and is not intended to indicate whether what is registered is an international interest or a prospective international interest. Similarly, with reference to Article 19(4) and 19(5) of the Cape Town Convention, "assignment" is not intended to indicate whether what is registered is an assignment or a prospective assignment, and, in conformity with Article III of the Aircraft Protocol, "sale" is not intended to indicate whether what is registered is a sale or a prospective sale.

The International Registry system is designed to use percentages with a maximum of six decimal places when recording fractional and partial interests in aircraft objects e.g. 12.123456%. Please consider that certain fractions cannot be fully represented within six decimal places. Percentages shown are of the full aircraft object.

*The International Registry was notified that this entity had a change of name within the meaning set out in the Regulations and Procedures for the International Registry.

Name Change History			
Entity Reference	Old Name	New Name	Date Changed on International Registry
0000011534	Union Bank, N.A.	MUFG Union Bank, N.A.	17-Nov-2014
0000011534	Union Bank of California, N.A.	Union Bank, N.A.	22-Jul-2009
0000044112	Wells Fargo Bank Northwest, National Association, as Owner Trustee	Wells Fargo Trust Company, National Association, as Owner Trustee	04-May-2018
0214802006	Virgin Blue Airlines Pty Limited	Virgin Australia Airlines Pty Limited	11-May-2011

Supplementary Priority Search Information

This information table contains supplementary priority search information provided pursuant to Section 7.8 of the Regulations for the International Registry. Supplementary priority search information is provided for information purposes only to assist users in reviewing the registered information contained in the priority search certificate. **Users must review all registered information contained in the priority search certificate and not just the information contained in the supplementary priority search information.** In the case of inconsistency between the registered information contained in the priority search certificate and the supplementary priority search information, the registered information contained in the priority search certificate shall prevail. Any such inconsistency and any inaccuracy discovered should be reported to the Registrar within 72 hours of receipt of the priority search certificate by the user.

Date	Type	File Number	Fractional or Partial Interest	Fully Discharged	Discharged by File Number(s)	Date of Full Discharge
31 Aug 2007 00:20:18 GMT	Sale	168297__	100.000000%	-__	-	-
22 Dec 2014 21:08:04 GMT	International Interest	1149212__	100.000000%	YES	1438962	27 Sep 2017
22 Dec 2014 22:19:07 GMT	Sale	1149311__	100.000000%	-__	-	-
22 Dec 2014 22:39:02 GMT	International Interest	1149351__	100.000000%	YES	1224613	02 Oct 2015
22 Dec 2014 22:43:04 GMT	Assignment of an International Interest	1149361__	100.000000%	YES	1224614	02 Oct 2015
29 Jan 2015 17:56:02 GMT	International Interest	1157989__	100.000000%	YES	1224615	02 Oct 2015
29 Jan 2015 18:02:02 GMT	Assignment of an International Interest	1158005__	100.000000%	YES	1224616	02 Oct 2015
31 Mar 2015 21:04:06 GMT	International Interest	1174419__	100.000000%	YES	1224617	02 Oct 2015
31 Mar 2015 21:08:08 GMT	Assignment of an International Interest	1174427__	100.000000%	YES	1224618	02 Oct 2015
07 Jan 2016 18:40:12 GMT	International Interest	1253674__	100.000000%	YES	1311765	10 Aug 2016
07 Jan 2016 18:45:04 GMT	Assignment of an International Interest	1253677__	100.000000%	YES	1311766	10 Aug 2016
21 Apr 2016 14:23:20 GMT	International Interest	1280117__	100.000000%	YES	1438963	27 Sep 2017
27 Sep 2017 19:52:08 GMT	International Interest	1438964__	100.000000%	-__	-	-
13 Sep 2019 18:32:01 GMT	International Interest	1676734__	100.000000%	-__	-	-
13 Sep 2019 18:32:05 GMT	Assignment of an International Interest	1676735__	100.000000%	-__	-	-

Supplementary Priority Search Information

Date	Type	File Number	Fractional or Partial Interest	Fully Discharged	Discharged by File Number(s)	Date of Full Discharge
13 Sep 2019 18:32:11 GMT	International Interest	1676736__	100.000000%	-__	-	-
13 Sep 2019 18:32:15 GMT	Assignment of an International Interest	1676737__	100.000000%	-__	-	-
13 Sep 2019 18:32:20 GMT	Assignment of an International Interest	1676738__	100.000000%	-__	-	-



The Power of Flight

CFM56 Engines TRANSPORTATION GUIDE

February 2016

Product Support Engineering

CFM, CFM56, LEAP and the CFM logo are trademarks of CFM International, a 50/50 joint company between Snecma (Safran group) and GE. The information in this document is CFM Proprietary Information and is disclosed in confidence. It is the property of CFM International and its parent companies, and shall not be used, disclosed to others or reproduced without the express written consent of CFM. If consent is given for reproduction in whole or in part, this notice shall appear in any such reproduction in whole or in part. The information contained in this document may also be controlled by the U.S. and French export control laws. Unauthorized export or re-export is prohibited.

Table of Contents



Introduction

- 1 - Shipping Stand Main Features
- 2 - In-Plant Transportation Specifications
- 3 - Road Transportation Specifications
- 4 - Water Transportation Specifications
- 5 - Air Transportation Specifications
- 6 - Rail Transportation Specifications
- 7 - Engine Shipping Environment Protections
- 8 - Improper Transportation Disposition
- 9 - AMM & ESM Chapters References
- 10 - List of CFM approved Shipping Stands
- 11 - Shipping Stands Dimensions
- 12 - Shipping Stands Manufacturers Contacts
- 13 - CFM Customer Support Contacts



Introduction



Introduction

The purpose of CFM56 Engines Transportation Guide is:

- To help customers to properly transport their engines
- To gather CFM recommendations for engine shipment:
 - CFM Engine shipment requirements
 - CFM Engine Shipment Best practices
 - CFM Approved Shipping stands references and dimensions
- To provide guidance to CFM customers:
 - To clarify transportation recommendations
 - To help understanding of shipping stand use
 - To protect engines during shipment
 - To choose the most suitable way to transport engines
 - To plan adequate tools acquisitions
 - To aware of potential improper transportation consequences



Introduction

Non-respect of CFM recommendations leads to Improper Transportation Issues, which:

- Involve Airlines, Shops, Engine Lessors, Carriers, Insurances, OEM,...
- May have an adverse impact:
 - On main engine bearings due to Brinelling effect
 - On fuel and oil external pipes, brackets, controls and accessories due to stress and deformation
- May lead to:
 - Engine unserviceability
 - Costly consequences on operations
 - Spare engine needs
 - Unscheduled maintenance activities
 - High cost corrective actions

Follow CFM recommendations
to avoid high cost corrective actions

Introduction



CFM56 Engines Transportation Guide is based on:

- CFM transportation knowledge and experience:
 - All CFM56 ESM 72-00-00 – STORAGE Tasks
 - CESM 004 – Optimizing Bearing Care
 - October 2004 Fleet Highlites Article
- Aircraft Manufacturers and Shipping Stand Manufacturers manuals:
 - Boeing 737CL series/CFM56-3 Aircraft Maintenance Manual
 - Boeing 737NG series/CFM56-7B Aircraft Maintenance Manual
 - Airbus A320 series/CFM56-5A and CFM56-5B Aircraft Maintenance Manual
 - Airbus A340 series/CFM56-5C Aircraft Maintenance Manual
 - Applicable Shipping Stand Manufacturer Documentation

Use this booklet as a guide.
Always refer to the applicable CFM, Aircraft manufacturer and Shipping Stand manufacturer documentation.



1 - Shipping Stand Main Features

1 - Shipping Stand Main Features

Engine shipping stands :

- Are designed for shipment of:
 - « Bare » engines
 - « Quick Engine Change » (QEC) engines
- Are an assembly of:
 - A Cradle on which the engine is installed
 - A Stand Base on which the cradle is installed
 - A “Shock Absorbers” interface between Cradle and Stand Base

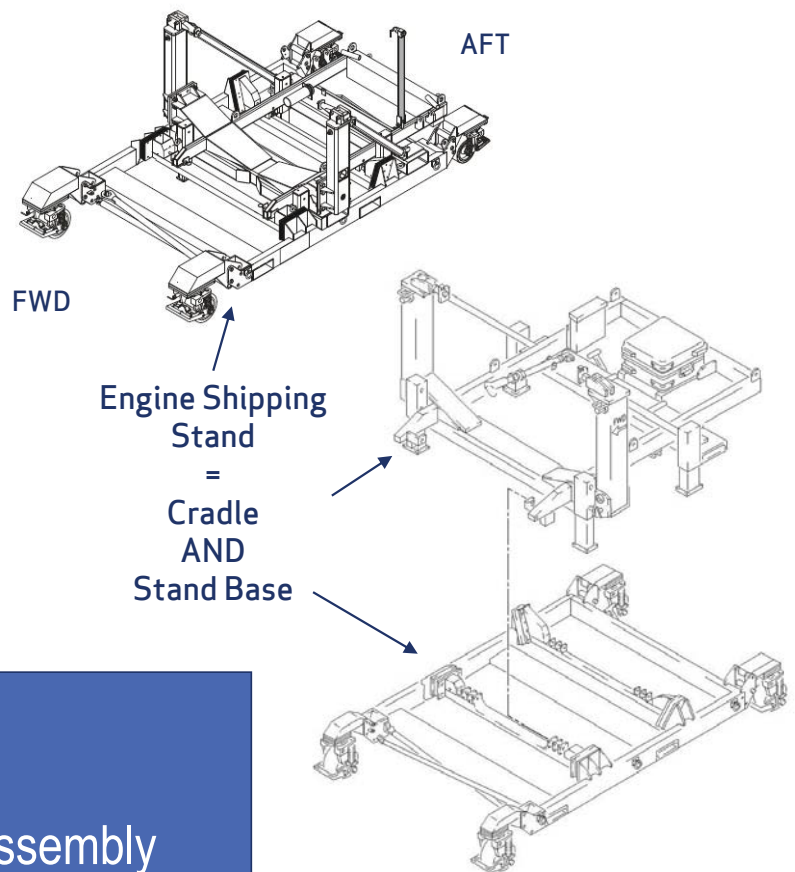

Engine Shipping Stand
=
« Cradle AND Stand Base » assembly



1 - Shipping Stand Main Features

All CFM qualified engine shipping stands are featured with the following main items:

- On the Stand Base:
 - Shock absorbers
 - « Air & Truck » tiedown rings
 - Fork-lift tunnels
 - Caster wheels
 - Tow Bars
- On the Engine Cradle:
 - « Air Only » tiedown rings
 - Forward Engine Mounting arms
 - AFT Engine mounting arm

Location of main features may change from one shipping stand to another.
Refer to the Shipping Stand Manufacturer Documentation.

1 - Shipping Stand Main Features

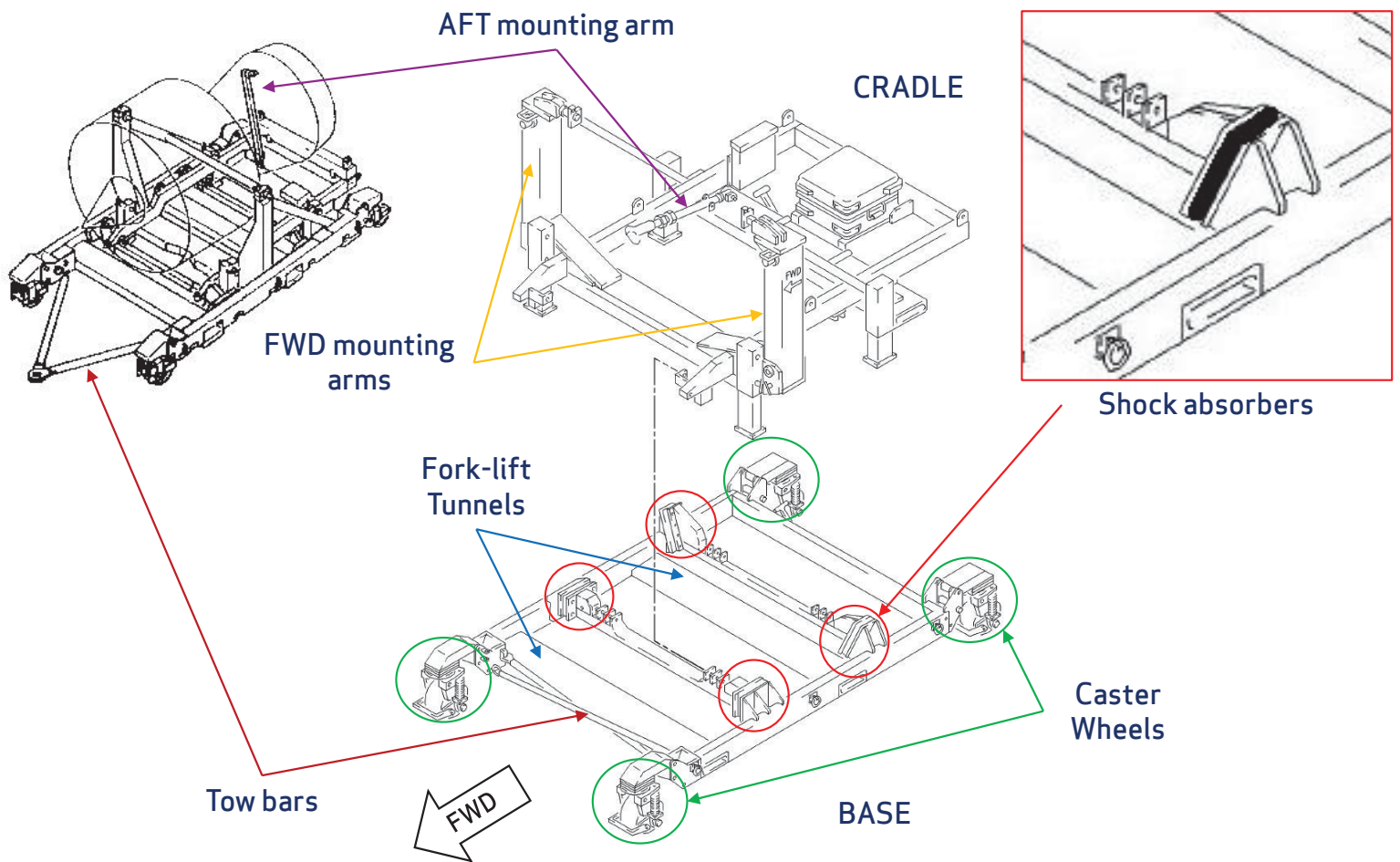



1 - Shipping Stand Main Features

Shipping Stand Tiedown points:

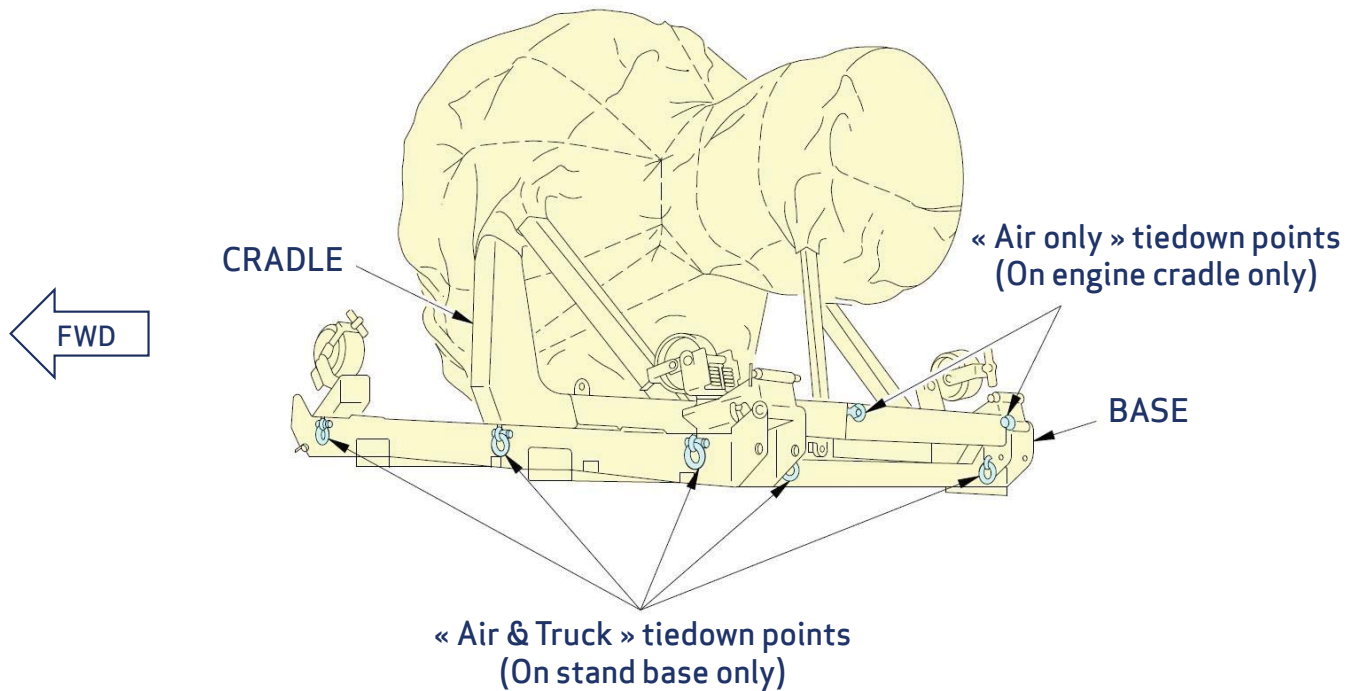

Stand Base Tiedown rings = Air & Truck transportation
Engine Cradle Tiedown rings = Air transportation ONLY



1 - Shipping Stand Main Features

Engine shipping stands requirements :

- **CFM Qualification :**
 - All shipping stands referenced in this document have successfully passed tests and are compliant with CFM requirements
- **On-Wing installation Capability:**
 - All Shipping stands referenced in this document are designed for On-Wing Bootstrap Installation procedure
 - The On-Wing installation procedure is the Aircraft manufacturer responsibility and is described in the applicable AMM
- **Shipping Stands condition:**
 - All Shipping stands referenced in this document may be used for CFM56 engines transportation provided that they are operated and maintained according to the applicable Shipping Stand Manufacturer Documentation

For Shipping stand operations and maintenance instructions, refer to Shipping Stand Manufacturer Documentation.



2 - In-Plant Transportation Specifications

2 - In-Plant Transportation Specifications



Engines installed on Shipping stands may be towed in facilities and inner access roads with the below conditions:

- Shipping stand conditions during towing:
 - Only stand base tow bars must be used
 - Spring-type casters or pneumatic tyres must be used
 - The 4 swivel locks of the casters must be released
 - Cradle must be free of attaching device, to keep the full efficiency of shock absorbers
- Engine towing operations conditions:
 - Maximum towing speed is 3 mph (5 km/h)
 - Towing must be performed on a smooth and horizontal surface
 - When necessary or after towing, caster braking system must be used to prevent movement of the assembly

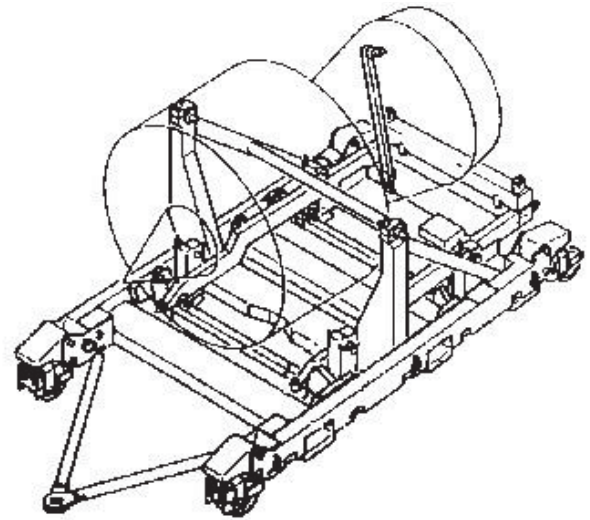

For towing operations, refer to Shipping Stand Manufacturer Documentation.



3 - Road Transportation Specifications



3 - Road Transportation Specifications

Roads and Highways transportation has to be compliant with the following:

- General requirements
- Vehicle suspension requirements
- Engine Cradle requirements
- Shipping stand base tiedown requirements

These requirements are detailed in the next pages.

All these requirements prevent damage to the engine due to shock and vibration loads during transportation.

3 - Road Transportation Specifications



General requirements:

- Engine must be installed on a shipping stand (Cradle and Base)
- The « engine and shipping stand » assembly may be shipped in a Tractor and trailer truck, or a wagon-bed truck
- The « engine and shipping stand » assembly must be installed lengthwise and must not protrude from the vehicle bed
- Caster wheels and tow bars must be locked in storage position
- Engine must be protected against environment



Tractor and trailer truck

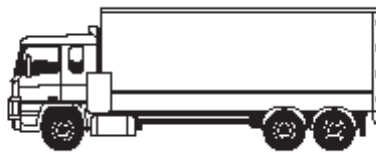

Wagon-bed truck

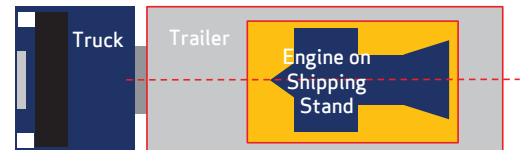

Shipping stand installed lengthwise and not protruding

3 - Road Transportation Specifications



Vehicle Suspension requirements:

- Must ensure a natural frequency range filtration from 7 to 10 Hz of the “engine and shipping stand” assembly
- Highly recommended suspensions type:
 - “Air ride” (Pneumatic)
 - “Hydraulic with Nitrogen Accumulators” (Hydropneumatic)
- Vehicle restrictions depending on suspensions type used:
 - Pneumatic: no restriction
 - Hydropneumatic: Maximum speed limit is 25mph (40km/h)
- Suspensions disposition on vehicle:
 - 1 engine shipped on a trailer: trailer axles must be pneumatically suspended
 - 2 or more engines shipped on a trailer: all axles must be pneumatically suspended
 - 1 or more engines shipped on a wagon-bed truck: all axles must be pneumatically suspended

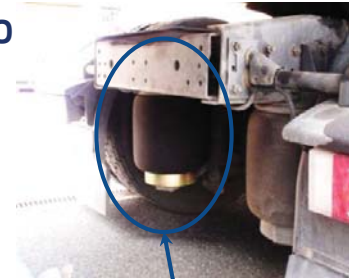

Gas accumulator example of an « Air ride » (pneumatic) suspension

3 - Road Transportation Specifications



Engine Cradle requirements:

- Engine must be installed and secured on the cradle
- The cradle must be installed on the stand base via shock absorbers
- The cradle must be free of any attaching device to keep full efficiency of shock absorbers:
 - “Air Only” tiedown points must not be used
 - No strap (or chain) installed over the cradle
 - Cover installed on the engine must not be tied down to the truck bed or the base of the Shipping Stand
 - Shock absorbers must be free to move
- Clearance between engine cradle and trailer bed:
 - Minimum clearance: 2 in. (51 mm) to avoid cradle to trailer bed contact during shock absorbers run
 - If necessary, Wooden shims may be put in place between Stand Base and trailer bed

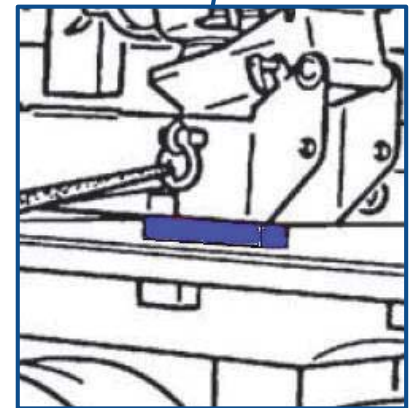
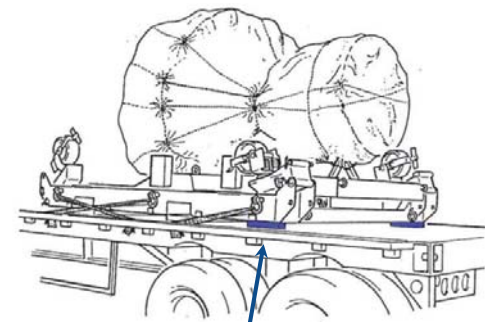

Wooden shims between Stand Base and Trailer bed



3 - Road Transportation Specifications

Shipping Stand Base tiedown requirements (1/5):

- Shipping Stand configuration:
 - Only the Base of the shipping stand must be attached to the trailer
 - Cradle and engine must not be attached neither to the trailer nor to the Base
- Shipping Stand Base features to be used for attachment to the trailer:
 - « Air & Truck » Tiedown points
 - Forklift tunnels (Alternative only)
- Shipping stand base must be attached to the trailer using 1 of the 2 following devices only:
 - Straps attached to « Air & Truck » Tiedown points.
 - Note: Use of chains within « Air & Truck » Tiedown points can cause damage to the shipping stand
 - Chains installed through Forklift tunnels (Alternative Only)

Engine and Cradle must stay free of attaching device.
Only the Stand Base must be attached to the trailer.



3 - Road Transportation Specifications

Shipping Stand Base tiedown requirements (2/5):

- Recommended methods: Straps attached to « Air & Truck » Tiedown points (See Methods 1 & 2):
 - Use 4 straps as a minimum. Whenever possible, the use of 6, 8 or 10 straps is recommended.
 - Attach straps to « Air & Truck » tiedown points on Stand Base
 - Pull them diagonally accross the trailer bed
 - Secure straps to the anchoring points on the trailer bed
- Alternative method: Chains installed through Forklift tunnels (See Method 3):
 - Only to be used if Recommended methods (Methods 1 & 2) are not applicable
 - Pull chains through forward and afterward Forklift tunnels of the Stand Base
 - Secure chains to the anchoring points on the trailer bed

3 - Road Transportation Specifications



Shipping Stand Base tiedown requirements (3/5):
Method 1 (Recommended): 8 to 10 straps attached to
« Air & Truck » tiedown points

8 to 10 straps attached to
« Air & Truck » Tiedown points

« Air only » tiedown points
(On engine cradle only)
FORBIDDEN

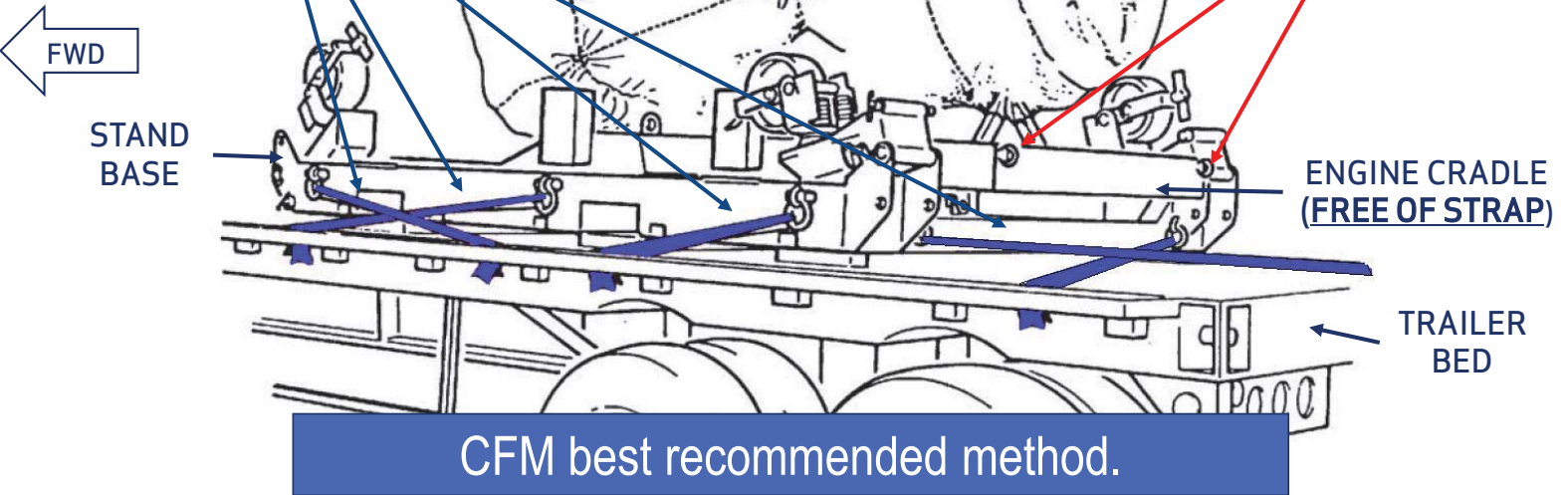

22 / CFM Proprietary Information subject to restrictions on the cover

3 - Road Transportation Specifications



Shipping Stand Base tiedown requirements (4/5):
Method 2 (Recommended): 4 to 6 straps attached to
« Air & Truck » tiedown points

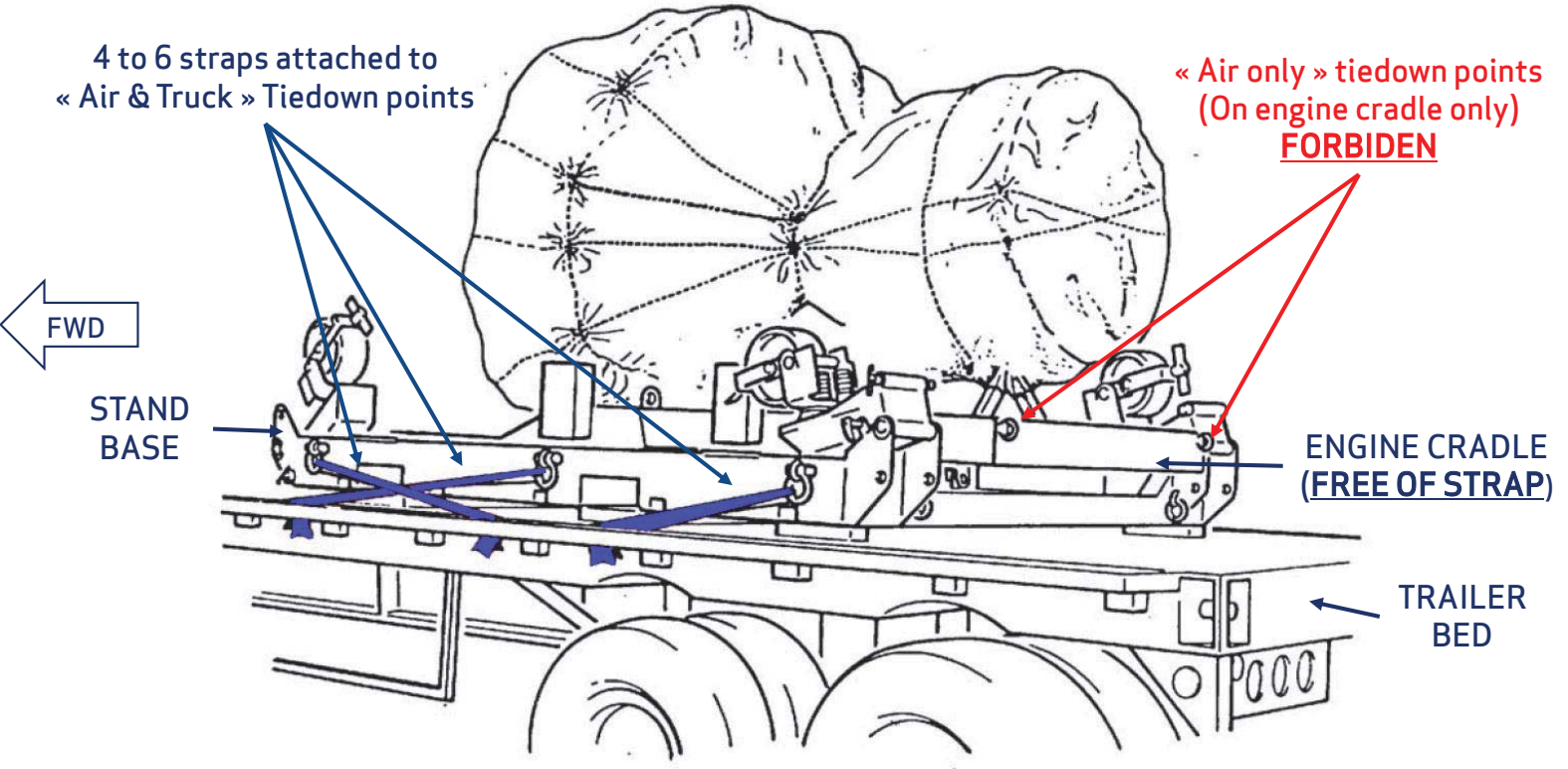

23 / CFM Proprietary Information subject to restrictions on the cover

3 - Road Transportation Specifications



Shipping Stand Base tiedown requirements (5/5):
Method 3 (Alternative, when Methods 1 and 2 are not possible):
Chains installed through Forklift Tunnels

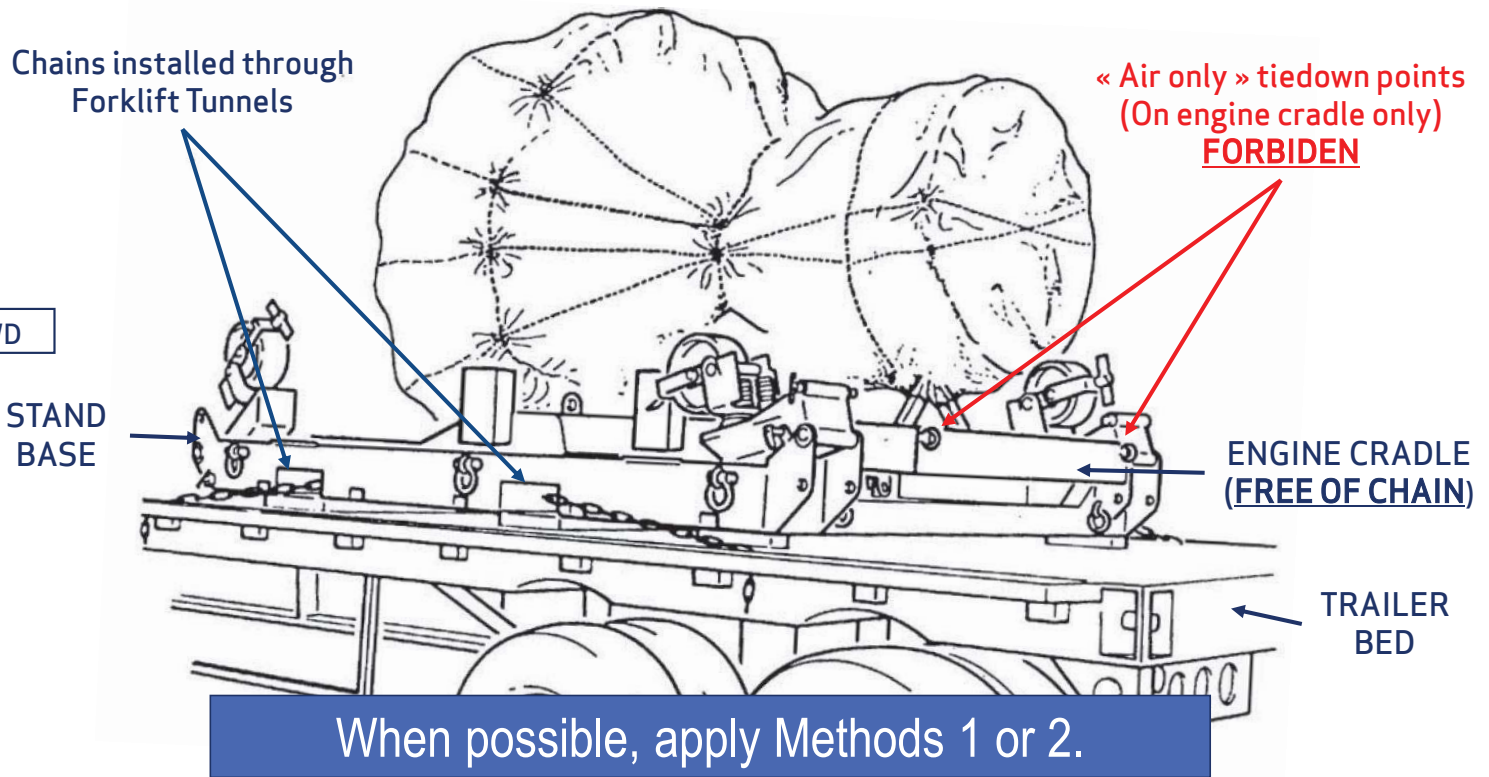



4 - Water Transportation Specifications



4 - Water Transportation Specifications

- « Engine and shipping stand » assembly must be installed on a Tractor and trailer truck or a wagon-bed truck, parked on-board a Ferry Boat
- Road Transportation requirements must be followed
- Trailer and truck suspensions must be active during all the travel
- Engine must be protected against environment
- Engine exposure to salty air must not exceed 8 days, including loading and unloading sequences



Road Transportation Specifications are concurrent requirement with Water Transportation.



5 - Air Transportation Specifications



5 - Air Transportation Specifications

Air Shipment on Shipping Stand assembly (Recommended):

- Engine must be transported in a cargo aircraft on a Shipping Stand assembly as follows:
 - Engine installed and secured on engine Cradle
 - Engine Cradle installed on Stand Base, via Shock Absorbers
 - « Engine and Shipping Stand » assembly installed on a Standard Air Cargo Pallet : 125 x 88 x 2 in. (3175 x 2235.2 x 51 mm)
- Shipping Stand tiedown on Standard Air Cargo Pallet:
 - Use only « Air & Truck » tiedown points on Stand Base
 - Use 4, 6, 8 or 10 straps from « Air & Truck » tiedown points to pallet fitting points
- Shipping Stand configuration requirements for Air Shipment:
 - Ensure a 2 in. (51 mm) minimum clearance between Cradle and pallet, using wooden shims if necessary
 - Caster Wheels and Tow Bars must be locked in storage position

CFM recommends air shipment on Shipping Stand assembly



5 - Air Transportation Specifications

Air Shipment on Cradle Only (Alternative only):

- Engine may be transported in a Cargo aircraft on a Cradle without Stand Base, provided that:
 - Aircraft Accessibility is not possible to the Engine and Shipping Stand Assembly installed on a Standard Air Cargo Pallet
 - AND Aircraft Accessibility is possible to the Engine and Cradle Assembly installed on a Standard Air Cargo Pallet
 - AND Cradle has been designed for Engine Air Shipment on Cradle without Stand Base
- Cradle tiedown on Standard Air Cargo Pallet:
 - Use « Air Only » tiedown points on Cradle
 - Use 4, 6, 8 or 10 straps from « Air Only» tiedown points to pallet fitting points

When Aircraft cargo bay is accessible,
prefer to use the « Air Shipment on Shipping Stand » procedure.



5 - Air Transportation Specifications

Aircraft Accessibility for Engine and Shipping Stand Assembly (For information only):

- Examples of accessible aircraft for Engine and Shipping Stand Assembly (but not limited to):
 - Airbus: A300F, A310F
 - Antonov AN-12, AN-124
 - Boeing: B707, B720, B727, B737, B747F, B767F, B777F
 - Douglas and McDonnell-Douglas: DC-9F, DC-10, MD-11F
 - Ilyushin: IL-76
 - Lockheed: L-100, C-130
 - Transall: C160

For final aircraft accessibility aptitude,
Always refer to Cargo Aircraft Manufacturer or Cargo Aircraft Operator.



6 - Rail Transportation Specifications

6 - Rail Transportation Specifications



Engine Shipment by train is forbidden:

- Engine Shipping Stands are not qualified to protect engines during shipment by train
- « Engine on Shipping Stand » assembly installed on a trailer bed parked on a train is not qualified
- If an engine has been shipped by train, contact CFM Customer Support Center in order to get CFM recommendations

Do not transport a CFM56 engine by train



7 – Engine Shipping Environment Protections



7 – Engine Shipping Environment Protections

Engine must be protected against environment:

- Engine Shipping conditions expose the engine to the environment:
 - Moisture, water ingestion and weather conditions
 - Sand, dust and foreign objects ingestion
- Environment may have an adverse impact on the engine hardware:
 - Corrosion on engine Bearing parts which may lead to spalling/failure
 - Sand and dust ingestion, which may lead to engine damage
- CFM recommendations as described in the next pages:
 - To follow Preservation/Storage tasks requirements
 - To put an adequate Shipping Cover all over the engine

During engine transportation, comply with Preservation/Storage tasks and put adequate cover all over the engine.



7 – Engine Shipping Environment Protections

Engine Preservation/Storage requirements during shipment:

- Protection of engine hardware:
 - Oil wetted parts, including Bearings
 - Fuel wetted parts
 - Engine Gaspath hardware
- Several Preservation/Storage tasks adapted to each duration:
 - Short periods: up to 30 days
 - Long periods: up to 90 days (Boeing & Airbus AMM only), up to 365 days
- CFM mostly recommends to follow Preservation/Storage tasks for long period because:
 - It deals with Oil wetted parts protection (and Fuel wetted parts if 365 days preservation procedure applied)
 - It gives the best protection for Gaspath (Desiccant Bags, Vapor Barrier Film)
 - It prevents any delay that may occur during Transportation

Long period preservation tasks are recommended

7 – Engine Shipping Environment Protections



Engine Shipping Covers (1/2):

- Covers CFM requirements:
 - To be waterproof
 - To be installed over the whole engine
 - To be « tight-fitted » to the engine
 - Must not be attached in any manner to the trailer bed or to the base of the Shipping Stand
- CFM covers are specifically designed:
 - To adapt to Bare engines or QEC'd engines installed on Shipping Stands
 - To avoid water retention (for last versions)
 - To provide easy access to inlet and exhausts for desiccant bags and humidity indicator inspection
 - To be removable without need of sharp/cutting tools
 - To be fully re-usable

CFM56 engines must be covered during shipment

7 – Engine Shipping Environment Protections



Engine Shipping Covers (2/2):

CFM Shipping Covers		
Engine Model	Engine Configuration	
	Bare	QEC'd
CFM56-2C	856A1280P01	856A1192P01
CFM56-3	856A3595G02	856A3505G01
CFM56-5A	856A2782G01	856A2782G02
CFM56-5B	856A2930G01 (*)	856A2930G02
	856A2930G03	
	856A2930G04	
CFM56-5C	856A2330G01	856A2330G02
CFM56-7B	856A3700G01 (*)	856A3700G02
	856A3700G03	
	856A3700G04	
NOTE 1: PART NUMBERS FOLLOWED BY "(*)" ARE NOT PROCURABLE.		

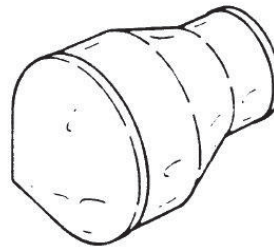

CFM Shipping Cover for Bare engine

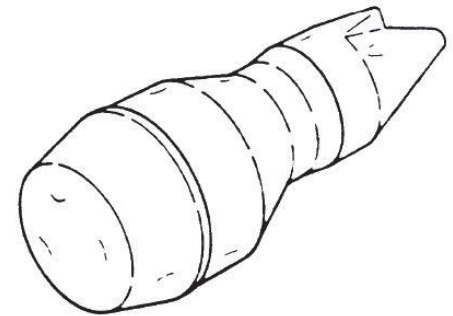

CFM Shipping Cover for QEC'd engine



8 - Improper Transportation Disposition

8 - Improper Transportation Disposition



- Improper Transportation is defined as non-compliance with AMM/ESM procedures
- It may have an adverse impact:
 - On main engine bearings
 - On fuel and oil external pipes, brackets, controls and accessories

In case of Improper Transportation,
Contact CFM



8 - Improper Transportation Disposition

- Minimum information to provide to CFM:
 - CFM56 engine model and ESN
 - Description of the deviation with general and detailed pictures of the improper transportation issue and evidences
 - Shipping Stand model: Base P/N and Cradle P/N
 - Shipping Stand Shock Absorbers status
 - Truck and trailer suspension type: “Air ride” (Pneumatic) or not.
 - Shipping Stand attachment pictures (must be sufficient to determine attachment configuration, tie-down points used, straps or chains position)
 - Engine improperly transported going to airline for return to service or going to shop visit ?
 - If going to Shop Visit : workscope to be applied on the engine

The more detailed the information is,
the more appropriate CFM recommendations will be.



9 – AMM & ESM Chapters References



9 – AMM & ESM Chapters References

Most of transportation recommendations detailed previously come from:

- AMM and ESM:
 - CFM56-3 – Engine Shop Manual
 - CFM56-5A – Engine Shop Manual
 - CFM56-5B – Engine Shop Manual
 - CFM56-5C – Engine Shop Manual
 - CFM56-7B – Engine Shop Manual
 - Boeing 737CL series/CFM56-3 Aircraft Maintenance Manual
 - Boeing 737NG series/CFM56-7B Aircraft Maintenance Manual
 - Airbus A320 series/CFM56-5A and CFM56-5B Aircraft Maintenance Manual
 - Airbus A340 series/CFM56-5C Aircraft Maintenance Manual
- More specifically:
 - Engine Transportation Chapters
 - Engine Removal and Installation from/on Aircraft Chapters
 - Engine Preservation Chapters

9 – AMM & ESM Chapters References



Engine Transportation Chapters:

TRANSPORTATION OF THE ENGINE		
Engine Model	AMM	ESM
CFM56-3	71-00-04/201 POWERPLANT - MAINTENANCE PRACTICES (ENGINE TRANSPORTATION)	72-00-00 - ENGINE - GENERAL - STORAGE 002
CFM56-5A	N/A	72-00-00 - ENGINE - GENERAL - STORAGE
CFM56-5B	N/A	72-00-00 - ENGINE - GENERAL - STORAGE
CFM56-5C	N/A	72-00-00 - ENGINE - GENERAL - STORAGE
CFM56-7B	71-00-04/201 POWERPLANT - MAINTENANCE PRACTICES (ENGINE TRANSPORTATION)	72-00-00 - ENGINE - GENERAL - STORAGE 002

9 – AMM & ESM Chapters References



Engine Removal and Installation from/on Aircraft Chapters:

REMOVAL AND INSTALLATION OF THE ENGINE FROM THE AIRCRAFT		
Engine Model	AMM	ESM
CFM56-3	71-00-02/401 POWERPLANT - REMOVAL/INSTALLATION	N/A
CFM56-5A	71-00-00 PB401 - POWERPLANT - GENERAL - DEACTIVATION/REACTIVATION	N/A
CFM56-5B	71-00-00 PB401 - POWERPLANT - GENERAL - DEACTIVATION/REACTIVATION	N/A
CFM56-5C	71-00-00 PB401 - POWERPLANT - GENERAL - DEACTIVATION/REACTIVATION	N/A
CFM56-7B	71-00-02/401 POWERPLANT - REMOVAL/INSTALLATION	N/A

9 – AMM & ESM Chapters References



Engine Preservation Chapters:

PRESERVATION OF THE ENGINE		
Engine Model	AMM	ESM
CFM56-3	71-00-03/201 POWERPLANT - MAINTENANCE PRACTICES (PRESERVATION AND DEPRESERVATION)	72-00-00 - ENGINE - GENERAL - STORAGE 001
CFM56-5A	72-00-00 PB301 - ENGINE - GENERAL - SERVICING	72-00-00 - ENGINE - GENERAL - STORAGE
CFM56-5B	72-00-00 PB301 - ENGINE - GENERAL - SERVICING	72-00-00 - ENGINE - GENERAL - STORAGE
CFM56-5C	72-00-00 PB301 - ENGINE - GENERAL - SERVICING	72-00-00 - ENGINE - GENERAL - STORAGE
CFM56-7B	71-00-03/201 POWERPLANT - MAINTENANCE PRACTICES (PRESERVATION AND DEPRESERVATION)	72-00-00 - ENGINE - GENERAL - STORAGE 001



10 – List of CFM approved Shipping Stands



10 – List of CFM approved Shipping Stands

- Shipping Stands listed in the next pages:
 - Meet all the CFM Tool Design Office requirements
 - Have passed all the tests required by CFM Tool Design Office
 - Have been submitted to CFM Tool Design Office approval
 - Have been certified compliant with CFM requirements
- CFM Tool Design Office requirements for shipping stands have been specifically given in order to protect the engine during shipment
- In case of engine shipment with a shipping stand not approved, CFM is not able to provide technical support.

For CFM56 engine shipment,
Use CFM approved Shipping Stands

10 – List of CFM approved Shipping Stands



CFM APPROVED SHIPPING STANDS MANUFACTURERS OVERVIEW						
	CFM56-2C	CFM56-3	CFM56-5A	CFM56-5B	CFM56-5C	CFM56-7B
AGSE LLC		X	X	X	X	X
C&F Millier Ltd. (*)		X	X		X	
CFM	X					
Dedienne Aerospace			X	X		X
Frank Brown & Son Ltd.		X	X	X	X	X
Stanley Aviation		X	X	X	X	X
NOTE 1: MANUFACTURERS FOLLOWED BY "(*)" ARE NOT IN THE SHIPPING STAND BUSINESS ANYMORE						

10 – List of CFM approved Shipping Stands



AGSE LLC			
	Shipping Stand	Cradle	Base
CFM56-2C	N/A	N/A	N/A
CFM56-3	(Cradle + Base P/N)	AM1802	AM2563
CFM56-5A	(Cradle + Base P/N)	AM2088	AM2563
	(Cradle + Base P/N)	AM2718	
	(Cradle + Base P/N)	E208-G01	
CFM56-5B	(Cradle + Base P/N)	AM2718	AM2563
	(Cradle + Base P/N)	E208-G01	
CFM56-5C	(Cradle + Base P/N)	AM2387	AM2563
CFM56-7B	(Cradle + Base P/N)	AM2811	AM2563
C&F Millier Ltd.			
	Shipping Stand	Cradle	Base
CFM56-2C	N/A	N/A	N/A
CFM56-3	(Cradle + Base P/N)	CFD 1157 (*)	CFD 1237 (*)
CFM56-5A	(Cradle + Base P/N)	CFD 1208 (*)	CFD 1237 (*)
CFM56-5B	N/A	N/A	N/A
CFM56-5C	(Cradle + Base P/N)	CFD 1400-00 (*)	CFD 1400-02 (*)
CFM56-7B	N/A	N/A	N/A
NOTE 1: C&F MILLIER LTD. IS NOT IN THE SHIPPING STANDS BUSINESS ANYMORE.			
NOTE 2: PART NUMBER FOLLOWED BY "(*)" ARE NOT PROCURABLE ANYMORE.			

10 – List of CFM approved Shipping Stands



CFM			
	Shipping Stand	Cradle	Base
CFM56-2C	(Cradle + Base P/N)	856A1201G06	856A1202G04
CFM56-3	N/A	N/A	N/A
CFM56-5A	N/A	N/A	N/A
CFM56-5B	N/A	N/A	N/A
CFM56-5C	N/A	N/A	N/A
CFM56-7B	N/A	N/A	N/A

Dedienne Aerospace			
	Shipping Stand	Cradle	Base
CFM56-2C	N/A	N/A	N/A
CFM56-3	N/A	N/A	N/A
CFM56-5A	D71STA00004G03 (*)	D71CRA00004G03 (*)	D71TRO00005G01
	D71STA00004G08	D71CRA00004G09	
CFM56-5B	D71STA00004G03 (*)	D71CRA00004G03 (*)	D71TRO00005G01
	D71STA00004G08	D71CRA00004G09	
CFM56-5C	N/A	N/A	N/A
CFM56-7B	D71STA00005G02	D71CRA00005G02	D71TRO00005G03
NOTE 1: PART NUMBERS FOLLOWED BY "(*)" ARE NOT PROCURABLE ANYMORE.			

10 – List of CFM approved Shipping Stands



Frank Brown & Son Ltd.			
	Shipping Stand	Cradle	Base
CFM56-2C	N/A	N/A	N/A
CFM56-3	(Cradle + Base P/N)	FB 70.0001	FB 70.0002
CFM56-5A	(Cradle + Base P/N)	FB 70010-1	FB 70010-2
CFM56-5B	(Cradle + Base P/N)	FB 70-010-1B	FB 70-077-200
CFM56-5C	(Cradle + Base P/N)	FB 70020-100	FB 70020-200
CFM56-7B	(Cradle + Base P/N)	FB70077-100	FB70077-200

Stanley Aviation			
	Shipping Stand	Cradle	Base
CFM56-2C	N/A	N/A	N/A
CFM56-3	(Cradle + Base P/N)	110702	110701
CFM56-5A	(Cradle + Base P/N)	111502-1	111515-1
CFM56-5B	(Cradle + Base P/N)	111502-1	111515-1
CFM56-5C	(Cradle + Base P/N)	111602	111515
CFM56-7B	(Cradle + Base P/N)	114702-1	114701-1



11 - Shipping Stands Dimensions

11 - Shipping Stands Dimensions



Shipping Stand (Base and Cradle) dimensions for CFM56-2C									
Characteristics			HEIGHT	WIDTH	LENGTH	LENGTH	WEIGHT	WEIGHT	WEIGHT
Engine Shipping Stand Model			with engine	with engine	with bare engine	with QEC engine	Stand Only	with bare engine	with QEC engine
BASE AND CRADLE									
Manufacturer: <i>Shipping Stand</i>									
CFMI	<i>Cradle</i>	856A1201G06	99	90	133	209	2 447	7 081	7 692
	<i>Base</i>	856A1202G04	(2515)	(2286)	(3378)	(5309)	(1110)	(3212)	(3489)
Engine Cradle dimensions for CFM56-2C									
Characteristics			HEIGHT	WIDTH	LENGTH	LENGTH	WEIGHT	WEIGHT	WEIGHT
Engine Cradle Model			with engine	with engine	with bare engine	with QEC engine	Cradle Only	with bare engine	with QEC engine
CRADLE ONLY									
Manufacturer:									
CFMI	<i>Cradle</i>	856A1201G06	97	86	129	209	1 049	5 683	6 294
			(2464)	(2184)	(3277)	(5309)	(476)	(2578)	(2855)
NOTE 1:									
DIMENSIONS ARE GIVEN IN INCHES WITH MILLIMETERS IN PARENTHESES.									
WEIGHTS ARE GIVEN IN POUNDS WITH KILOGRAMMES IN PARENTHESES.									
NOTE 2:									
HEIGHT INCLUDES STANDARD PALLET 2 INCHES THICK.									

11 - Shipping Stands Dimensions



Shipping Stands (Base and Cradle) dimensions for CFM56-3									
Characteristics			HEIGHT	WIDTH	LENGTH	LENGTH	WEIGHT	WEIGHT	WEIGHT
Engine Shipping Stand Model			with engine	with engine	with bare engine	with QEC engine	Stand Only	with bare engine	with QEC engine
BASE AND CRADLE									
Manufacturer: <i>Shipping Stand</i>									
AGSE	<i>Cradle</i>	AM1802	96	99	172	201	4 409	8 685	10 109
	<i>Base</i>	AM2563	(2438)	(2515)	(4369)	(5105)	(2000)	(3939)	(4585)
Manufacturer: <i>Shipping Stand</i>									
C&F Millier Ltd.	<i>Cradle</i>	CFD 1157 (*)	88	97	172	192	4 813	9 089	10 513
	<i>Base</i>	CFD 1237 (*)	(2235)	(2464)	(4369)	(4877)	(2183)	(4123)	(4769)
Manufacturer: <i>Shipping Stand</i>									
Frank Brown & Son	<i>Cradle</i>	FB 70.0001	79	97	132	192	4 497	8 773	10 197
	<i>Base</i>	FB 70.0002	(2007)	(2464)	(3353)	(4877)	(2040)	(3979)	(4625)
Manufacturer: <i>Shipping Stand</i>									
Stanley	<i>Cradle</i>	110702	93	98	125	192	3 550	7 826	9 250
	<i>Base</i>	110701	(2362)	(2489)	(3175)	(4877)	(1610)	(3550)	(4196)
<p>NOTE 1: DIMENSIONS ARE GIVEN IN INCHES WITH MILLIMETERS IN PARENTHESES. WEIGHTS ARE GIVEN IN POUNDS WITH KILOGRAMMES IN PARENTHESES.</p> <p>NOTE 2: HEIGHT INCLUDES STANDARD PALLET 2 INCHES THICK.</p> <p>NOTE 3: PART NUMBERS FOLLOWED BY "(*)" ARE NOT PROCURABLE ANYMORE.</p>									

11 - Shipping Stands Dimensions



Cradles dimensions for CFM56-3								
Characteristics	HEIGHT with engine	WIDTH with engine	LENGTH with bare engine	LENGTH with QEC engine	WEIGHT Cradle Only	WEIGHT with bare engine	WEIGHT with QEC engine	
Engine Cradle Model								
CRADLE ONLY								
Manufacturer: AGSE <i>Cradle</i> AM1802	92 (2337)	96 (2438)	132 (3353)	192 (4877)	1 232 (559)	5 508 (2498)	6 932 (3144)	
Manufacturer: C&F Millier Ltd. <i>Cradle</i> CFD 1157 (*)	76 (1930)	97 (2464)	137 (3480)	192 (4877)	1 174 (533)	5 450 (2472)	6 874 (3118)	
Manufacturer: Frank Brown & Son <i>Cradle</i> FB 70.0001	76 (1930)	97 (2464)	113 (2870)	192 (4877)	1 697 (770)	5 973 (2709)	7 397 (3355)	
Manufacturer: Stanley <i>Cradle</i> 110702	Shipment on Stanley's cradle is not possible without the base.							
<p>NOTE 1: DIMENSIONS ARE GIVEN IN INCHES WITH MILLIMETERS IN PARENTHESES. WEIGHTS ARE GIVEN IN POUNDS WITH KILOGRAMMES IN PARENTHESES.</p> <p>NOTE 2: HEIGHT INCLUDES STANDARD PALLET 2 INCHES THICK.</p> <p>NOTE 3: PART NUMBERS FOLLOWED BY "(*)" ARE NOT PROCURABLE ANYMORE.</p>								

11 - Shipping Stands Dimensions



Shipping Stands (Base and Cradle) dimensions for CFM56-5A (1/2)									
Characteristics			HEIGHT	WIDTH	LENGTH	LENGTH	WEIGHT	WEIGHT	WEIGHT
Engine Shipping Stand Model			with engine	with engine	with bare engine	with QEC engine	Stand Only	with bare engine	with QEC engine
BASE AND CRADLE									
Manufacturer: <i>Shipping Stand</i>									
AGSE	<i>Cradle</i>	AM2088	96	96	155	201	4 231	9 088	9 847
	<i>Base</i>	AM2563	(2438)	(2438)	(3937)	(5105)	(1919)	(4122)	(4467)
Manufacturer: <i>Shipping Stand</i>									
AGSE	<i>Cradle</i>	AM2718	101	99	157	201	4 385	9 242	10 001
	<i>Base</i>	AM2563	(2563)	(2515)	(3988)	(5099)	(1989)	(4192)	(4536)
Manufacturer: <i>Shipping Stand</i>									
AGSE	<i>Cradle</i>	E208-G01	101	99	153	201	5 803	10 660	11 419
	<i>Base</i>	AM2563	(2566)	(2515)	(3874)	(5099)	(2632)	(4835)	(5180)
Manufacturer: <i>Shipping Stand</i>									
C&F Millier Ltd.	<i>Cradle</i>	CFD 1208 (*)	88	97	172	201	4 813	9 670	10 429
	<i>Base</i>	CFD 1237 (*)	(2235)	(2464)	(4369)	(5099)	(2183)	(4386)	(4731)
<p>NOTE 1: DIMENSIONS ARE GIVEN IN INCHES WITH MILLIMETERS IN PARENTHESES. WEIGHTS ARE GIVEN IN POUNDS WITH KILOGRAMMES IN PARENTHESES.</p> <p>NOTE 2: HEIGHT INCLUDES STANDARD PALLET 2 INCHES THICK.</p> <p>NOTE 3: PART NUMBERS FOLLOWED BY "(*)" ARE NOT PROCURABLE ANYMORE.</p>									

11 - Shipping Stands Dimensions



Shipping Stands (Base and Cradle) dimensions for CFM56-5A (2/2)								
Characteristics		HEIGHT	WIDTH	LENGTH	LENGTH	WEIGHT	WEIGHT	WEIGHT
Engine Shipping Stand Model		with engine	with engine	with bare engine	with QEC engine	Stand Only	with bare engine	with QEC engine
BASE AND CRADLE								
Manufacturer: <i>Shipping Stand</i>	D71STA00004G03 (*)							
Dedienne <i>Cradle</i>	D71CRA00004G03 (*)	98	96	168	201	5 247	10 104	10 863
Aerospace <i>Base</i>	D71TRO00005G01	(2489)	(2438)	(4267)	(5105)	(2380)	(4583)	(4927)
Manufacturer: <i>Shipping Stand</i>	D71STA00004G08							
Dedienne <i>Cradle</i>	D71CRA00004G09	98	96	168	201	5 247	10 104	10 863
Aerospace <i>Base</i>	D71TRO00005G01	(2489)	(2438)	(4267)	(5105)	(2380)	(4583)	(4927)
Manufacturer: <i>Shipping Stand</i>								
Frank Brown <i>Cradle</i>	FB 70010-1	79	97	132	201	4 497	9 354	10 113
& Son <i>Base</i>	FB 70010-2	(2007)	(2464)	(3353)	(5099)	(2040)	(4243)	(4587)
Manufacturer: <i>Shipping Stand</i>								
Stanley <i>Cradle</i>	111502-1	93	98	125	201	3 550	8 407	9 166
<i>Base</i>	111515-1	(2362)	(2489)	(3175)	(5099)	(1610)	(3813)	(4158)
<p>NOTE 1: DIMENSIONS ARE GIVEN IN INCHES WITH MILLIMETERS IN PARENTHESES. WEIGHTS ARE GIVEN IN POUNDS WITH KILOGRAMMES IN PARENTHESES.</p> <p>NOTE 2: HEIGHT INCLUDES STANDARD PALLET 2 INCHES THICK.</p> <p>NOTE 3: PART NUMBERS FOLLOWED BY "(*)" ARE NOT PROCURABLE ANYMORE.</p>								

11 - Shipping Stands Dimensions



Cradles dimensions for CFM56-5A (1/2)									
Characteristics			HEIGHT	WIDTH	LENGTH	LENGTH	WEIGHT	WEIGHT	WEIGHT
Engine Cradle Model			with engine	with engine	with bare engine	with QEC engine	Cradle Only	with bare engine	with QEC engine
CRADLE ONLY									
Manufacturer:									
AGSE	<i>Cradle</i>	AM2088	92 (2337)	96 (2438)	132 (3353)	201 (5099)	1 631 (740)	6 488 (2943)	7 247 (3287)
Manufacturer:									
AGSE	<i>Cradle</i>	AM2718	107 (2712)	97 (2451)	116 (2943)	201 (5099)	1 784 (809)	6 641 (3012)	7 400 (3357)
Manufacturer:									
AGSE	<i>Cradle</i>	E208-G01	105 (2674)	96 (2438)	116 (2943)	201 (5099)	3 201 (1452)	8 058 (3655)	8 817 (3999)
Manufacturer:									
C&F Millier Ltd.	<i>Cradle</i>	CFD 1208 (*)	76 (1930)	96 (2438)	115 (2921)	201 (5099)	2 176 (987)	7 033 (3190)	7 792 (3534)
<p>NOTE 1: DIMENSIONS ARE GIVEN IN INCHES WITH MILLIMETERS IN PARENTHESES. WEIGHTS ARE GIVEN IN POUNDS WITH KILOGRAMMES IN PARENTHESES.</p> <p>NOTE 2: HEIGHT INCLUDES STANDARD PALLET 2 INCHES THICK.</p> <p>NOTE 3: PART NUMBERS FOLLOWED BY "(*)" ARE NOT PROCURABLE ANYMORE.</p>									

11 - Shipping Stands Dimensions



Cradles dimensions for CFM56-5A (2/2)								
Characteristics	HEIGHT with engine	WIDTH with engine	LENGTH with bare engine	LENGTH with QEC engine	WEIGHT Cradle Only	WEIGHT with bare engine	WEIGHT with QEC engine	
Engine Cradle Model								
CRADLE ONLY								
Manufacturer: Dedienne Cradle Aerospace	D71CRA00004G03 (*)	96 (2438)	96 (2438)	116 (2946)	201 (5105)	2 866 (1300)	7 723 (3503)	8 482 (3847)
Manufacturer: Dedienne Cradle Aerospace	D71CRA00004G09	96 (2438)	96 (2438)	116 (2946)	201 (5105)	2 866 (1300)	7 723 (3503)	8 482 (3847)
Manufacturer: Frank Brown Cradle & Son	FB 70010-1	92 (2337)	98 (2489)	116 (2946)	201 (5099)	2 050 (930)	6 907 (3133)	7 666 (3477)
Manufacturer: Stanley Cradle	111502-1	Shipment on Stanley's cradle is not possible without the base.						
<p>NOTE 1: DIMENSIONS ARE GIVEN IN INCHES WITH MILLIMETERS IN PARENTHESES. WEIGHTS ARE GIVEN IN POUNDS WITH KILOGRAMMES IN PARENTHESES.</p> <p>NOTE 2: HEIGHT INCLUDES STANDARD PALLET 2 INCHES THICK.</p> <p>NOTE 3: PART NUMBERS FOLLOWED BY "(*)" ARE NOT PROCURABLE ANYMORE.</p>								

11 - Shipping Stands Dimensions



Shipping Stands (Base and Cradle) dimensions for CFM56-5B (1/2)									
Characteristics			HEIGHT	WIDTH	LENGTH	LENGTH	WEIGHT	WEIGHT	WEIGHT
Engine Shipping Stand Model			with engine	with engine	with bare engine	with QEC engine	Stand Only	with bare engine	with QEC engine
BASE AND CRADLE									
Manufacturer: <i>Shipping Stand</i>									
AGSE	<i>Cradle</i>	AM2718	101	99	157	201	4 384	9 841	10 634
	<i>Base</i>	AM2563	(2563)	(2515)	(3988)	(5099)	(1989)	(4464)	(4824)
Manufacturer: <i>Shipping Stand</i>									
AGSE	<i>Cradle</i>	E208-G01	101	99	153	201	5 803	11 260	12 053
	<i>Base</i>	AM2563	(2566)	(2515)	(3874)	(5099)	(2632)	(5107)	(5467)
Manufacturer: <i>Shipping Stand</i>									
Dedienne	<i>Cradle</i>	D71STA00004G03 (*)	98	96	168	201	5 247	10 704	11 497
Aerospace	<i>Base</i>	D71CRA00004G03 (*)	(2489)	(2438)	(4267)	(5105)	(2380)	(4855)	(5215)
		D71TRO00005G01							
Manufacturer: <i>Shipping Stand</i>									
Dedienne	<i>Cradle</i>	D71STA00004G08	98	96	168	201	5 247	10 704	11 497
Aerospace	<i>Base</i>	D71CRA00004G09	(2489)	(2438)	(4267)	(5105)	(2380)	(4855)	(5215)
		D71TRO00005G01							
<p>NOTE 1: DIMENSIONS ARE GIVEN IN INCHES WITH MILLIMETERS IN PARENTHESES. WEIGHTS ARE GIVEN IN POUNDS WITH KILOGRAMMES IN PARENTHESES.</p> <p>NOTE 2: HEIGHT INCLUDES STANDARD PALLET 2 INCHES THICK.</p> <p>NOTE 3: PART NUMBERS FOLLOWED BY "(*)" ARE NOT PROCURABLE ANYMORE.</p>									

11 - Shipping Stands Dimensions



Shipping Stands (Base and Cradle) dimensions for CFM56-5B (2/2)

Characteristics		HEIGHT	WIDTH	LENGTH	LENGTH	WEIGHT	WEIGHT	WEIGHT
Engine Shipping Stand Model		with engine	with engine	with bare engine	with QEC engine	Stand Only	with bare engine	with QEC engine
BASE AND CRADLE								
Manufacturer: <i>Shipping Stand</i>								
Frank Brown & Son	<i>Cradle</i>	FB 70-010-1B	93	98	181	201	4 810	10 267
	<i>Base</i>	FB 70-077-200	(2362)	(2489)	(4597)	(5099)	(2182)	(4657)
			(5017)					
Manufacturer: <i>Shipping Stand</i>								
Stanley	<i>Cradle</i>	111502-1	95	98	142	201	5 520	10 977
	<i>Base</i>	111515-1	(2413)	(2489)	(3607)	(5099)	(2504)	(4979)
			(5339)					
NOTE 1:								
DIMENSIONS ARE GIVEN IN INCHES WITH MILLIMETERS IN PARENTHESES.								
WEIGHTS ARE GIVEN IN POUNDS WITH KILOGRAMMES IN PARENTHESES.								
NOTE 2:								
HEIGHT INCLUDES STANDARD PALLET 2 INCHES THICK.								

11 - Shipping Stands Dimensions



Cradles dimensions for CFM56-5B (1/2)									
Characteristics		HEIGHT	WIDTH	LENGTH	LENGTH	WEIGHT	WEIGHT	WEIGHT	
Engine Cradle Model		with engine	with engine	with bare engine	with QEC engine	Cradle Only	with bare engine	with QEC engine	
CRADLE ONLY									
Manufacturer:									
AGSE	<i>Cradle</i>	AM2718	107 (2712)	97 (2451)	116 (2943)	201 (5099)	1 784 (809)	7 241 (3284)	8 034 (3644)
Manufacturer:									
AGSE	<i>Cradle</i>	E208-G01	105 (2674)	96 (2438)	116 (2943)	201 (5099)	3 201 (1452)	8 658 (3927)	9 451 (4287)
Manufacturer:									
Dedienne Aerospace	<i>Cradle</i>	D71CRA00004G03 (*)	96 (2438)	96 (2438)	116 (2946)	201 (5105)	2 866 (1300)	8 323 (3775)	9 116 (4135)
Manufacturer:									
Dedienne Aerospace	<i>Cradle</i>	D71CRA00004G09	96 (2438)	96 (2438)	116 (2946)	201 (5105)	2 866 (1300)	8 323 (3775)	9 116 (4135)
NOTE 1: DIMENSIONS ARE GIVEN IN INCHES WITH MILLIMETERS IN PARENTHESES. WEIGHTS ARE GIVEN IN POUNDS WITH KILOGRAMMES IN PARENTHESES.									
NOTE 2: HEIGHT INCLUDES STANDARD PALLET 2 INCHES THICK.									
NOTE 3: PART NUMBERS FOLLOWED BY "(*)" ARE NOT PROCURABLE ANYMORE.									

11 - Shipping Stands Dimensions



Cradles dimensions for CFM56-5B (2/2)

Characteristics		HEIGHT	WIDTH	LENGTH	LENGTH	WEIGHT	WEIGHT	WEIGHT
Engine Cradle Model		with engine	with engine	with bare engine	with QEC engine	Cradle Only	with bare engine	with QEC engine
CRADLE ONLY								
Manufacturer:								
Frank Brown & Son	<i>Cradle</i> FB 70-010-1B	86 (2184)	98 (2489)	116 (2946)	198 (5029)	2 033 (922)	7 490 (3397)	8 283 (3757)
Manufacturer:		Shipment on Stanley's cradle is not possible without the base.						
Stanley	<i>Cradle</i> 111502-1							
NOTE 1: DIMENSIONS ARE GIVEN IN INCHES WITH MILLIMETERS IN PARENTHESES. WEIGHTS ARE GIVEN IN POUNDS WITH KILOGRAMMES IN PARENTHESES.								
NOTE 2: HEIGHT INCLUDES STANDARD PALLET 2 INCHES THICK.								

11 - Shipping Stands Dimensions



Shipping Stands (Base and Cradle) dimensions for CFM56-5C									
Characteristics			HEIGHT	WIDTH	LENGTH	LENGTH	WEIGHT	WEIGHT	WEIGHT
Engine Shipping Stand Model			with engine	with engine	with bare engine	with QEC engine	Stand Only	with bare engine	with QEC engine
BASE AND CRADLE									
Manufacturer: <i>Shipping Stand</i>									
AGSE	<i>Cradle</i>	AM2387	96	96	155	224	4 750	10 475	12 250
	<i>Base</i>	AM2563	(2438)	(2438)	(3937)	(5690)	(2155)	(4751)	(5557)
Manufacturer: <i>Shipping Stand</i>									
C&F Millier Ltd.	<i>Cradle</i>	CFD 1400-00 (*)	118	96	133	224	6 498	12 223	13 998
	<i>Base</i>	CFD 1400-02 (*)	(2997)	(2438)	(3378)	(5690)	(2947)	(5544)	(6349)
Manufacturer: <i>Shipping Stand</i>									
Frank Brown & Son	<i>Cradle</i>	FB 70020-100	114	102	181	224	4 912	10 637	12 412
	<i>Base</i>	FB 70020-200	(2896)	(2591)	(4597)	(5690)	(2228)	(4825)	(5630)
Manufacturer: <i>Shipping Stand</i>									
Stanley	<i>Cradle</i>	111602	107	98	172	224	4 450	10 175	11 950
	<i>Base</i>	111515	(2718)	(2489)	(4369)	(5690)	(2018)	(4615)	(5420)
<p>NOTE 1: DIMENSIONS ARE GIVEN IN INCHES WITH MILLIMETERS IN PARENTHESES. WEIGHTS ARE GIVEN IN POUNDS WITH KILOGRAMMES IN PARENTHESES.</p> <p>NOTE 2: HEIGHT INCLUDES STANDARD PALLET 2 INCHES THICK.</p> <p>NOTE 3: PART NUMBERS FOLLOWED BY "(*)" ARE NOT PROCURABLE ANYMORE.</p>									

11 - Shipping Stands Dimensions



Cradles dimensions for CFM56-5C								
Characteristics		HEIGHT with engine	WIDTH with engine	LENGTH with bare engine	LENGTH with QEC engine	WEIGHT Cradle Only	WEIGHT with bare engine	WEIGHT with QEC engine
Engine Cradle Model								
CRADLE ONLY								
Manufacturer: AGSE <i>Cradle</i>	AM2387	92 (2337)	96 (2438)	132 (3353)	224 (5690)	2 150 (975)	7 875 (3572)	9 650 (4377)
Manufacturer: C&F Millier Ltd. <i>Cradle</i>	CFD 1400-00 (*)	106 (2692)	96 (2438)	133 (3378)	224 (5690)	3 200 (1451)	8 925 (4048)	10 700 (4853)
Manufacturer: Frank Brown & Son <i>Cradle</i>	FB 70020-100	103 (2616)	102 (2591)	123 (3124)	224 (5690)	2 115 (959)	7 840 (3556)	9 615 (4361)
Manufacturer: Stanley <i>Cradle</i>	111602	Shipment on Stanley's cradle is not possible without the base.						
<p>NOTE 1: DIMENSIONS ARE GIVEN IN INCHES WITH MILLIMETERS IN PARENTHESES. WEIGHTS ARE GIVEN IN POUNDS WITH KILOGRAMMES IN PARENTHESES.</p> <p>NOTE 2: HEIGHT INCLUDES STANDARD PALLET 2 INCHES THICK.</p> <p>NOTE 3: PART NUMBERS FOLLOWED BY "(*)" ARE NOT PROCURABLE ANYMORE.</p>								

11 - Shipping Stands Dimensions



Shipping Stands (Base and Cradle) dimensions for CFM56-7B

Engine Shipping Stand Model		Characteristics	HEIGHT with engine	WIDTH with engine	LENGTH with bare engine	LENGTH with QEC engine	WEIGHT Stand Only	WEIGHT with bare engine	WEIGHT with QEC engine
BASE AND CRADLE									
Manufacturer: <i>Shipping Stand</i>									
AGSE	<i>Cradle</i>	AM2811	96	99	171	201	4 420	9 573	10 848
	<i>Base</i>	AM2563	(2438)	(2515)	(4343)	(5105)	(2005)	(4342)	(4921)
Manufacturer: <i>Shipping Stand</i>		D71STA00005G02							
Dedienne	<i>Cradle</i>	D71CRA00005G02	94	99	194	207	4 828	9 981	11 256
Aerospace	<i>Base</i>	D71TRO00005G03	(2388)	(2515)	(4928)	(5258)	(2190)	(4527)	(5106)
Manufacturer: <i>Shipping Stand</i>									
Frank Brown & Son	<i>Cradle</i>	FB70077-100	89	96	143	236	4 799	9 952	11 227
	<i>Base</i>	FB70077-200	(2261)	(2438)	(3632)	(5994)	(2177)	(4514)	(5092)
Manufacturer: <i>Shipping Stand</i>									
Stanley	<i>Cradle</i>	114702-1	87	98	128	207	3 918	9 071	10 346
	<i>Base</i>	114701-1	(2210)	(2489)	(3251)	(5258)	(1777)	(4115)	(4693)
NOTE 1:									
DIMENSIONS ARE GIVEN IN INCHES WITH MILLIMETERS IN PARENTHESES.									
WEIGHTS ARE GIVEN IN POUNDS WITH KILOGRAMMES IN PARENTHESES.									
NOTE 2:									
HEIGHT INCLUDES STANDARD PALLET 2 INCHES THICK.									

11 - Shipping Stands Dimensions



Cradles dimensions for CFM56-7B								
Characteristics	HEIGHT with engine	WIDTH with engine	LENGTH with bare engine	LENGTH with QEC engine	WEIGHT Stand Only	WEIGHT with bare engine	WEIGHT with QEC engine	
Engine Cradle Model								
CRADLE ONLY								
Manufacturer: AGSE <i>Cradle</i> AM2811	92 (2337)	96 (2438)	132 (3353)	199 (5055)	1 821 (826)	6 974 (3163)	8 249 (3742)	
Manufacturer: Dedienne Aerospace <i>Cradle</i> D71CRA00005G02	91 (2311)	95 (2413)	105 (2667)	207 (5258)	2 205 (1000)	7 358 (3338)	8 633 (3916)	
Manufacturer: Frank Brown & Son <i>Cradle</i> FB70077-100	85 (2159)	96 (2438)	118 (2997)	207 (5258)	2 000 (907)	7 153 (3245)	8 428 (3823)	
Manufacturer: Stanley <i>Cradle</i> 114702-1	Shipment on Stanley's cradle is not possible without the base.							
<p>NOTE 1: DIMENSIONS ARE GIVEN IN INCHES WITH MILLIMETERS IN PARENTHESES. WEIGHTS ARE GIVEN IN POUNDS WITH KILOGRAMMES IN PARENTHESES.</p> <p>NOTE 2: HEIGHT INCLUDES STANDARD PALLET 2 INCHES THICK.</p>								



12 - Shipping Stands Manufacturers Contacts

12 - Shipping Stands Manufacturers Contacts



Name	AGSE LLC	Stanley Aviation
Address	10805 Painter Avenue Santa Fe Springs CA 90670 U.S.A.	
Telephone	+1 562-906-9300	
Fax	+1 562-906-9308	
Website	www.agsecorp.com	www.stanley-aviation.com
Email	agse@agsecorp.com	sales@stanley-aviation.com

Name	Dedienne Aerospace
Address	ZAC de Saint Martin 5 rue Gaye Marie 31300 Toulouse France
Telephone	+33 (0) 5 61 06 77 79
Website	www.dedienne-aero.com
Email	contact@dedienne-aero.com

Name	Frank Brown & Son Ltd.
Address	87 - 105 Wingate Road Luton LU4 8QA United Kingdom
Telephone	+44 (0)1582 597246
Fax	+44 (0)1582 505959
Website	www.frankbrown.co.uk
Email	enquiries@frankbrown.co.uk

Name	CFM S.A.	CFM Inc.
Address	Snecma 2, chemin de Viercy Aérodrome de Villaroche 77019 Montereau-sur-le-Jard France	1 Neumann Way Cincinnati OH 45215 U.S.A.
Telephone	+33 (0) 1 64 14 88 66	+1 513-552-3272
Fax	+33 (0) 1 64 79 85 55	+1 513-552-3329
Website	www.cfmaeroengines.com	
Email	snecma.csc@snecma.fr	geae.aoc@ge.com
		geae.choc@ge.com



13 - CFM Customer Support Contacts

13 - CFM Customer Support Contacts



For any information regarding CFM56 engine transportation, please contact CFM Customer Support:

Name	CFM S.A.	CFM Inc.
Address	Snecma 2, chemin de Viercy Aérodrome de Villaroche 77019 Montereau-sur-le-Jard France	1 Neumann Way Cincinnati OH 45215 U.S.A.
Telephone	+33 (0) 1 64 14 88 66	+1 513-552-3272
Fax	+33 (0) 1 64 79 85 55	+1 513-552-3329
Website	www.cfmaeroengines.com	
Email	snecma.csc@snecma.fr	geae.aoc@ge.com
		geae.choc@ge.com

1. Approving Civil Aviation Authority/Country: FAA/United States		2. AUTHORIZED RELEASE CERTIFICATE FAA Form 8130-3, AIRWORTHINESS APPROVAL TAG			3. Form Tracking Number:	
4. Organization Name and Address:					5. Work Order/Contract/Invoice Number:	
6. Item:	7. Description:	8. Part Number:	9. Quantity:	10. Serial Number:	11. Status/Work:	
12. Remarks:						
13a. Certifies the items identified above were manufactured in conformity to: <input type="checkbox"/> Approved design data and are in a condition for safe operation. <input type="checkbox"/> Non-approved design data specified in Block 12.			14a. <input type="checkbox"/> 14 CFR 43.9 Return to Service <input type="checkbox"/> Other regulation specified in Block 12 Certifies that unless otherwise specified in Block 12, the work identified in Block 11 and described in Block 12 was accomplished in accordance with Title 14, Code of Federal Regulations, part 43 and in respect to that work, the items are approved for return to service.			
13b. Authorized Signature:		13c. Approval/Authorization No.:	14b. Authorized Signature:		14c. Approval/Certificate No.:	
13d. Name (Typed or Printed):		13e. Date (dd/mmm/yyyy):	14d. Name (Typed or Printed):		14e. Date (dd/mmm/yyyy):	
User/Installer Responsibilities						
<p>It is important to understand that the existence of this document alone does not automatically constitute authority to install the aircraft engine/propeller/article.</p> <p>Where the user/installer performs work in accordance with the national regulations of an airworthiness authority different than the airworthiness authority of the country specified in Block 1, it is essential that the user/installer ensures that his/her airworthiness authority accepts aircraft engine(s)/propeller(s)/article(s) from the airworthiness authority of the country specified in Block 1.</p> <p>Statements in Blocks 13a and 14a do not constitute installation certification. In all cases, aircraft maintenance records must contain an installation certification issued in accordance with the national regulations by the user/installer before the aircraft may be flown.</p>						

1. Approving Component Authority /Country Swedish Transport Agency / Sweden		2.				3. Form Tracking number	
AUTHORISED RELEASE CERTIFICATE EASA FORM 1						5. Work Order/Contract/Invoice	
4. Organisation Name and Address							
6. Item	7. Description	8. Part No	9. Qty	10. Serial No	11. Status/Work		
12. Remarks							
13.a. Certifies that the items identified above were manufactured in conformity to: <input type="checkbox"/> approved design data and are in a condition for safe operation <input type="checkbox"/> non-approved design data specified in block 12				14.a <input type="checkbox"/> Part-145.A.50 Release to Service <input type="checkbox"/> Other regulation specified in block 12 Certifies that unless otherwise specified in block 12, the work identified in block 11 and described in block 12, was accomplished in accordance with Part-145 and in respect to that work the items are considered ready for release to service.			
13.b. Authorised Signature		13.c. Approval/Authorisation Number		14.b. Authorised Signature		14.c. Certificate/Approval Ref.No.	
13.d. Name		13.e. Date (dd mmm yyyy)		14.d. Name		14.e. Date (dd mmm yyyy)	
USER/INSTALLER RESPONSIBILITIES This certificate does not automatically constitute authority to install the item(s). Where the user/installer performs work in accordance with regulations of an airworthiness authority different than the airworthiness authority specified in block 1, it is essential that the user/installer ensures that his/her airworthiness authority accepts items from the airworthiness authority specified in block 1. Statements in block 13a and 14 a do not constitute installation certification. In all cases aircraft maintenance records must contain an installation certification issued in accordance with the national regulations by the user/installer before the aircraft may be flown.							



US Department
of Transportation
**Federal Aviation
Administration**

**MAJOR REPAIR AND ALTERATION
(Airframe, Powerplant, Propeller, or Appliance)**

OMB No. 2120-0020
Exp: 5/31/2018

Electronic Tracking Number

For FAA Use Only

INSTRUCTIONS: Print or type all entries. See Title 14 CFR §43.9, Part 43 Appendix B, and AC 43.9-1 (or subsequent revision thereof) for instructions and disposition of this form. This report is required by law (49 U.S.C. §44701). Failure to report can result in a civil penalty for each such violation. (49 U.S.C. §46301(a))

1. Aircraft	Nationality and Registration Mark	Serial No.		
	Make	Model	Series	
2. Owner	Name (As shown on registration certificate)		Address (As shown on registration certificate)	
	Address		City _____ State _____	
	City		Zip _____ Country _____	
	Zip		Country	

3. For FAA Use Only

4. Type		5. Unit Identification			
Repair	Alteration	Unit	Make	Model	Serial No.
<input type="checkbox"/>	<input type="checkbox"/>	AIRFRAME	_____	(As described in Item 1 above)	_____
<input type="checkbox"/>	<input type="checkbox"/>	POWERPLANT			
<input type="checkbox"/>	<input type="checkbox"/>	PROPELLER			
<input type="checkbox"/>	<input type="checkbox"/>	APPLIANCE	Type		
			Manufacturer		

6. Conformity Statement

A. Agency's Name and Address		B. Kind of Agency	
Name _____	City _____ State _____ Zip _____ Country _____	<input type="checkbox"/> U. S. Certificated Mechanic	<input type="checkbox"/> Manufacturer
Address _____		<input type="checkbox"/> Foreign Certificated Mechanic	C. Certificate No.
City _____ State _____		<input type="checkbox"/> Certificated Repair Station	
Zip _____ Country _____		<input type="checkbox"/> Certificated Maintenance Organization	

D. I certify that the repair and/or alteration made to the unit(s) identified in item 5 above and described on the reverse or attachments hereto have been made in accordance with the requirements of Part 43 of the U.S. Federal Aviation Regulations and that the information furnished herein is true and correct to the best of my knowledge.

Extended range fuel per 14 CFR Part 43 App. B <input type="checkbox"/>	Signature/Date of Authorized Individual
--	---

7. Approval for Return to Service

Pursuant to the authority given persons specified below, the unit identified in item 5 was inspected in the manner prescribed by the Administrator of the Federal Aviation Administration and is Approved Rejected

BY	FAA Flt. Standards Inspector	Manufacturer	Maintenance Organization	Persons Approved by Canadian Department of Transport
	FAA Designee	Repair Station	Inspection Authorization	

Certificate or Designation No.	Signature/Date of Authorized Individual
--------------------------------	---

NOTICE

Weight and balance or operating limitation changes shall be entered in the appropriate aircraft record. An alteration must be compatible with all previous alterations to assure continued conformity with the applicable airworthiness requirements.

8. Description of Work Accomplished

(If more space is required, attach additional sheets. Identify with aircraft nationality and registration mark and date work completed.)

Nationality and Registration Mark Date

Additional Sheets Are Attached

To be printed on *Tigerair Australia* letterhead

ENGINE CERTIFICATION

This statement certifies that Engine CFM56-7B26 serial number 888473, has not been involved in an incident or accident, major failure, or fire, nor has the Engine or the parts installed thereon, been immersed in salt water or exposed to corrosive agents outside normal operation, been subjected to extreme stress or heat nor been obtained from any Government, Military or Unapproved Source while Leased and/or Operated by Tigerair Australia, and in the case of a part installed on the engine while Leased and/or Operated by Tigerair Australia, has not been subjected to, or removed from an engine that has been involved in an incident or accident, major failure, or fire, or has been subjected to extreme stress or heat nor been obtained from any Government, Military or Unapproved Source.

No Non-OEM Approved Repairs were performed on the Engine or its installed QEC
No Non-OEM approved PMA parts were installed and/or incorporated on the Engine or its installed QEC

Engine status at time of Delivery to Tigerair Australia:

Engine Total Time: 49,263.58 Engine Total Cycles: 41,644 Date: August 28th, 2019

Engine status at time of Cease of operation & Redelivery to Virgin Australia Airlines Pty Ltd/VB LeaseCo Pty Ltd:

Engine Total Time: 50,975.10 Engine Total Cycles: 42,633 Date: 1 July 2020

Company: _____

Signature: _____

Name: _____

Title: _____

Date: _____

(Note - This document should be certified by an authorized person in QA or Engineering)

ESN: 888473

Model/Type(Mark):	CFM56-7B24	Data at Date:	8 July 2020
Current Power Rating:	7B26	TSN:	50,975.10
		CSN:	42,633

Requirements					
AD Ref	SB Ref/Related Info	Title	Effective Date	Supersedure	Tracked Component
98-14-51 DGAC 98-259(B)R1	72-132, 72-130	Check the AGB and TGB magnetic chip detectors for abnormal magnetic particles	01 Oct 98	Supersedes: T98-14-51	
T98-14-51	72-132, 72-130	Check the AGB and TGB magnetic chip detectors (MCD) for abnormal magnetic particles.	02 Jul 98	Superseded By: 98-14-51 DGAC 98-259(B)R1	
T98-18-51		To prevent an uncommanded engine acceleration event inspect for the presence of engine EEC fault messages for both engines	28 Aug 98	Superseded By: 98-21-23 DGAC 98-350(B)R2	
98-19-20 DGAC 98-162(B)R1	73-016R2	To prevent failure of the HMU overspeed governor (OSG) spool shaft valve inspect the HMU p/n 1853M56P04 (Allied Signal p/n 442008) and 1853M56P05 (Allied Signal p/n 442026)	07 Oct 98		
98-21-11 (Airframe)		To prevent failure of the APU or engine fire detection system to detect a fire in a timely manner, replace affected fire detectors having serial numbers noted in AD	21 Oct 98		
98-21-23 DGAC 98-350(B)R2	73-A024, AOW 98/CFM56/312R1	To prevent an uncommanded engine acceleration event inspect for the presence of engine EEC fault messages for both engines.	02 Nov 98	Supersedes: T98-18-51	
2000-12-01 DGAC 2000-294-IMP(B)		To prevent critical life limited rotating engine part failure	11 Dec 00	Supersedes: 99-08-16 Superseded By: 2002-13-03 DGAC 2002-390-IMP(B)	
2001-02-12 DGAC 2001-057(B)	75-0005	To prevent air leakage from incorrectly torqued fittings of the PS3 pressure line	14 Feb 01		

Last Accomplishment Data		Next Due Data		Method of Compliance
Status		Status		
N/A		N/A		SB 72-0130R1 N/A & 72-0132 N/A to ESN 888473 AGB Installed p/n 340-046-509-0 s/n WQ3945
N/A		N/A		Superseded by AD 98-14-51
N/A		N/A		Superseded by AD 98-21-23
N/A		N/A		SB 73-0016R2 N/A to HMU p/n 1853M56P15 (p/n 442652) s/n BAMW5239MFR installed
N/A		N/A		N/A to Fire Detectors installed: LWR - p/n S332T100-30 s/n 3194 RH - p/n 902018-01 s/n 5577 LH - p/n 902862 s/n 5165 UPR - p/n S332T100-44 s/n 1251
N/A		N/A		N/A to ECU software p/n 2044M25P19 (7.B.W2F3) installed
N/A		N/A		Superseded by AD 2002-13-03
N/A		N/A		N/A to ESN 888473

Airworthiness Directive Status Report

Requirements					
AD Ref	SB Ref/Related Info	Title	Effective Date	Supersedure	Tracked Component
2001-11-05 DGAC 2001-240(B)		To prevent #4 Bearing failures. Applicable to installed P/N 305-355-717-0 only.	11 Jun 01		
2002-13-03 DGAC 2002-390-IMP(B)		To prevent critical life-limited rotating engine part failure.	01 Aug 02	Supersedes: 2000-12-01 DGAC 2000-294-IMP(B)	
2002-14-21 (Airframe)	Boeing 737-73A1011R2	To prevent major fuel leakage due to excessive wear of the quick-disconnect coupling on the fuel hose	21 Aug 02	Supersedes: 99-03-08	
2002-16-18 DGAC 2002-470(B)	72-0241R1	To aid in containment of the LPT rotor in the event of LPT shaft failure	18 Sep 02		
2003-03-01 (Airframe)	Boeing ASB 737-71A1462R1	To prevent increased structural loads on the aft engine mount	13 Feb 03	Superseded By: 2011-18-10 (Airframe)	
2003-03-01 (Airframe) Part 1	Boeing ASB 737-71A1462R1	To prevent increased structural loads on the aft engine mount (Inspection and correction of aft engine mounts)	13 Feb 03	Superseded By: 2011-18-10 (Airframe) Part 1	

Last Accomplishment Data		Next Due Data		Method of Compliance
Status		Status		
N/A		N/A		N/A to ESN 888473 and #4 Roller Bearing p/n 335-352-303-0 s/n DE834272 installed
Complied With	Date: 30 Jul 15 ETT: 40,482.00 ETC: 35,619	Perform at next piece-part exposure		The following LLPs were installed new at MTU W/O 53.322.400 on 30/Jul/2015: - Spool Booster - p/n 340-000-816-0 s/n PA801721 Shaft CPRSR Rotor - p/n 1386M56P03 s/n NCU22941 Spool Assy CPRSR Stg 1&2 - p/n 1558M31G07 s/n GWN0WDJF Disk STG 3 - p/n 2116M23P01 s/n XAEDU678 Spool Compressor Rotor 4-9 - p/n 2048M20G04 s/n GWN0W9CG Seal Rotating Air Rear - p/n 2116M25P01 s/n GFF5J1N6 Shaft HPT Rotor Front - p/n 2048M21P03 s/n XAEEJ269 Seal Rotating Air HPT Front - p/n 2116M20P02 s/n TMT3T789 Disk HPT Rotor - p/n 1498M43P07 s/n GWN0WA13 Shaft HPT Rear - p/n 1864M90P04 s/n TMATA9132 Disk LPT STG 1 - p/n 336-001-804-0 s/n PC154978 Disk LPT STG 2 - p/n 336-001-909-0 s/n PA753350 Disk LPT STG 3 - p/n 336-002-006-0 s/n PC187016 Disk LPT STG 4 - p/n 336-002-105-0 s/n PC223622 Support RTR LPT - p/n 340-301-702-0 s/n DH768444 Shaft LPT - p/n 340-074-723-0 s/n PC176110 Inspect at next piece-part exposure
N/A		N/A		N/A due to Fuel Supply Hose p/n AE713733-1 s/n T0971 (with B-Nut Connectors) installed
N/A		N/A		N/A to STG 2 and STG 3 Nozzle Segments Installed. STG 2 Nozzles Installed p/n 338-109-107-0 9ea p/n 338-109-207-0 8ea p/n 338-109-307-0 1ea STG 3 Nozzles Installed p/n 338-109-704-0 20ea p/n 338-109-804-0 1ea
N/A		N/A		Superseded by AD 2011-18-10
N/A		N/A		Superseded by AD 2011-18-10

Airworthiness Directive Status Report

Requirements					
AD Ref	SB Ref/Related Info	Title	Effective Date	Supersedure	Tracked Component
2003-03-01 (Airframe) Part 2	Boeing ASB 737-71A1462R1	To prevent increased structural loads on the aft engine mount (Mark the hanger fitting and center link)	13 Feb 03	Superseded By: 2011-18-10 (Airframe) Part 2	
2006-26-01		To prevent the loss of engine thrust that could result in loss of control during takeoff or landing. Do not install certain Western Filter or PTI Technologies fuel filter p/ns.	17 Jan 07		
2008-03-09 EASA AD 2007-0104	72-0579R8 (rev date: 1-25-2012)	To prevent failure of the TRF from low-cycle fatigue cracks (LPT rear frame inspection limits)	10 Mar 08		LPT Rotor - LPT Rear Frame 340-166-206-0
2009-11-02		To prevent cracking of the HPC 4-9 spools that Propulsion Technology LLC improperly repaired and returned to service	23 Jun 09		HPC Rotor - HPC Stg 4-9 Spool
2010-01-05 EASA AD 2009-0009	72-0579R8 , 72-0558R4	To prevent failure of the LPT rear frame from low-cycle fatigue cracks	18 Feb 10		LPT Rotor - LPT Rear Frame
2010-13-09 EASA AD 2009-0270	CFM56-5B SB 72-0733R1, CFM56-7B SB 72-0743R1	To prevent uncontained failure of the LPT stage 3 disk, replace suspect disks p/n 336-002-006-0 having serial numbers referenced in AD	26 Jul 10		LPT Rotor - LPT Stg 3 Disk 336-002-006-0
2011-18-10 (Airframe)	Boeing ASB 737-71A1462R3	To prevent increased structural loads on the aft engine mount	07 Nov 11	Supersedes: 2003-03-01	
2011-18-10 (Airframe) Part 1	Boeing ASB 737-71A1462R3	To prevent increased structural loads on the aft engine mount (Inspection and correction of aft engine mounts)	07 Nov 11	Supersedes: 2003-03-01	
2011-18-10 (Airframe) Part 2	Boeing ASB 737-71A1462R3	To prevent increased structural loads on the aft engine mount (Mark the hanger fitting and center link)	07 Nov 11	Supersedes: 2003-03-01	

Last Accomplishment Data		Next Due Data		Method of Compliance
Status		Status		
N/A		N/A		Superseded by AD 2011-18-10
Complied With	Date: 10 Jul 19 ETT: 49,263.58 ETC: 41,644	Review at each fuel filter replacement		C/W at GEES Dallas WO#10926K P/C/W by JES WO# JER4603 Note: Can be accomplished In-Shop or On-Wing
Complied With	Date: 16 Jul 18 ETT: 48,750.15 ETC: 41,332 PTT: 48,750.15 PTC: 41,332	Open	ETC: 46,032 PTC: 46,032	C/W by Southwest Airlines LPT Rear Frame p/n 340-166-206-0 s/n LA086164 installed Perform repetitive inspection every 4,700 cycles. If cracks are found, refer to Fig 803 of the AD for re-inspection intervals
N/A		N/A		N/A to HPC STG 4-9 Spool p/n 2048M20G04 s/n GWN0W9CG installed
N/A		N/A		N/A to LPT Rear Frame p/n 340-166-206-0 s/n LA086164 installed
N/A		N/A		N/A based on ESN 888473 and LPT STG 3 Disk p/n 2116M23P01 s/n PC187016 installed
Complied With	Date: 10 Sep 19 ETT: 49,294.83 ETC: 41,649	Inspect at each engine installation		C/W @ Virgin Australia W/O 168912 AFT Mount p/n 310A2030-17 s/n MRBK3091 installed Inspect Center Link Assembly of Aft Engine Mount for proper installation at each engine installation
Complied With	Date: 10 Sep 19 ETT: 49,294.83 ETC: 41,649	Inspect at each engine installation		C/W @ Virgin Australia W/O 168912 AFT Mount p/n 310A2030-17 s/n MRBK3091 installed Inspect Center Link Assembly of Aft Engine Mount for proper installation at each engine installation
Complied With	Date: 31 Jul 15 ETT: 40,482.00 ETC: 35,619	Terminated		C/W by MTU Maintenance WO# 5332240088 AFT Mount p/n 310A2030-17 s/n UNK installed AFT Mount is marked properly

Airworthiness Directive Status Report

Requirements					
AD Ref	SB Ref/Related Info	Title	Effective Date	Supersedure	Tracked Component
2012-05-02 (Airframe)	Boeing SB 737-78-1082	To detect and correct heat damage to the inner wall of the thrust reversers	10 May 12		
2013-08-01 (Airframe)	Boeing SB 737-78-1086R1	To detect and correct damage to the fire seals, perform one-time general visual inspection of the left and right thrust reverser halves	10 Jun 13		
2013-26-01 EASA AD 2012-0209	CFM56-3 SB 72-1129R3, CFM56-7B 72-0564R5, CFM56-7B SB 72-0879R1	To prevent loss of engine oil while in flight, perform repeat inspection of AGB handcranking pad cover and/or replace AGB with an improved AGB	03 Feb 14		
2013-26-01 EASA AD 2012-0209 par(f)	CFM56-3 SB 72-1129R2, CFM56-7B 72-0564R5, CFM56-7B SB 72-0879R1	To prevent loss of engine oil while in flight, perform repeat inspection of AGB handcranking pad cover	03 Feb 14		
2013-26-01 EASA AD 2012-0209 par(g)	CFM56-3 SB 72-1129R2, CFM56-7B 72-0564R5, CFM56-7B SB 72-0879R1	To prevent loss of engine oil while in flight, replace AGB with an improved AGB (Terminating Action)	03 Feb 14		
EASA AD 2014-0130	CFM56-5B TR 05-0223, CFM56-7B TR 05-0163	Time Limits - Engine Stationary Parts - Life Limits / Mandatory Inspections	03 Jun 14		
2015-04-02 EASA AD 2014-0261	SB 73-0203 SB 73-0204 EASA AD 2014-0261	EEC Software update to 7.B.W	31 Mar 15		
2015-18-04 EASA AD 2015-0133	CFM56-7B SB 72-0964 CFM56-7B SB 72-0965 AOW 15-CFM56-730 - States that 100% of affected gearshafts have been located and removed from service.	Accessory Gearbox Gearshaft - Inspection / replacement of affected 41-tooth AGB gearshaft P/N 335-303-002-0 and 73-tooth AGB gearshaft P/N 335-302-902-0 installed on CFM56-7B engines. Note: From effective date do not install any affected gearshafts identified in appendix 1 & 2 of EASA AD 2015-0133 on any CFM56-3 or CFM56-7B engine.	22 Jul 15		

Last Accomplishment Data		Next Due Data		Method of Compliance
Status		Status		
N/A		N/A		N/A due to Thrust Reverser is NOT provided Operator is responsible for compliance
N/A		N/A		Thrust Reverser Halves are NOT provided Operator is responsible for compliance
Complied With	Date: 31 Jul 15 ETT: 40,482.00 ETC: 35,619	Terminated		C/W SB 72-879 @ MTU Maintenance WO# 5332240088 AGB p/n 340-046-509-0 s/n WQ3945 installed
Complied With	Date: 31 Jul 15 ETT: 40,482.00 ETC: 35,619	Terminated		C/W SB 72-879 @ MTU Maintenance WO# 5332240088 AGB p/n 340-046-509-0 s/n WQ3945 installed
Complied With	Date: 31 Jul 15 ETT: 40,482.00 ETC: 35,619	Terminated		C/W SB 72-879 @ MTU Maintenance WO# 5332240088 AGB p/n 340-046-509-0 s/n WQ3945 installed
Complied With	Date: 31 Jul 15 ETT: 40,482.00 ETC: 35,619	Terminated		C/W @ MTU Maintenance WO# 5332240088 LPT Frame Assy installed p/n 340-166-206-0 s/n LA086164
Complied With	Date: 31 Jul 15 ETT: 40,482.00 ETC: 35,619	Terminated		C/W @ MTU Maintenance WO# 5332240088 ECU Software installed p/n 2044M25P19
N/A		N/A		N/A to AGB p/n 340-046-509-0 s/n WQ3945 installed N/A to 41-tooth gearshaft s/n UN20659 installed N/A to 73-tooth gearshaft s/n UN10655 installed

Airworthiness Directive Status Report

Requirements					
AD Ref	SB Ref/Related Info	Title	Effective Date	Supersedure	Tracked Component
2018-0071	72-1019 R1 72-1024	Engine - Fan Blades – Inspection	02 Apr 18	Superseded By: 2018-0093-E	
2018-0093-E	72-1033 EASA Emergency AD 2018-0093-E AMOC (1 & 2) FAA AD 2018-09-51-E FAA AD 2018-09-51-E (AMOC 1, 2 & 3) FAA AD 22018-09-10	Engine - Fan Blades - Inspection	20 Apr 18	Supersedes: 2018-0071 Superseded By: 2018-0109	
2018-0109	72-1033 R1 FAA AD 2018-10-11	Engine - Fan Blades - Inspection	18 May 18	Supersedes: 2018-0093-E Superseded By: 2018-0211	
2018-0211	SB 72-1033 R2	Engine - Fan Blades – Inspection	05 Oct 18	Supersedes: 2018-0109 Superseded By: 2019-0018	
2018-09-10	EASA AD 2018-0093-E FAA AD 2018-09-51-E AMOC to FAA AD 2018-09-10 SB 72-1033	Engine - Fan Blades - Inspection	14 May 18	Superseded By: 2018-10-11	
2018-09-51-E	FAA EAD 2018-09-51-E AMOC (1, 2 & 3) EASA EAD 2018-0093 EASA 2018-0093-E AMOC (1 & 2) SB 72-1033	Engine - Fan Blades - Inspection	20 Apr 18		
2018-09-51	FAA AD 2018-10-11 FAA EAD 2018-09-51-E EASA AD 2018-0109 SB 72-1033 R1	Engine - Fan Blades - Inspection	07 Jun 18		
2018-10-11	72-1033 R1 EASA AD 2018-0109	Engine - Fan Blades - Inspection	01 Jun 18	Supersedes: 2018-09-10 Superseded By: 2018-18-01	
2018-18-01	EASA AD 2018-0211 SB 72-1033 R2	Engine - Fan Blades - Inspection	16 Oct 18	Supersedes: 2018-10-11 Superseded By: 2018-26-01	
2018-26-01	72-1033 R3	ATA 72 - Engine - Fan Blades - Inspection	10 Jan 19	Supersedes: 2018-18-01	
2019-0018	Refer to FAA AD 2018-26-01 Refer to SB 72-1033 R3	Engine - Fan Blades – Inspection	13 Feb 19	Supersedes: 2018-0211	
2019-0146	72-1074 R1 (-SB) 72-0794 R1 (-SC) 72-1042 R1 (-7B)	ATA 72 – Engine – Rotating Air High Pressure Turbine Front Seal – Replacement	28 Jun 19	Superseded By: 2019-0150	

Last Accomplishment Data		Next Due Data		Method of Compliance
Status		Status		
N/A		N/A		N/A Superseded by AD 2018-0093-E
N/A		N/A		N/A superseded by AD 2018-0109
N/A		N/A		N/A - Superseded by 2018-0211
N/A		N/A		N/A – AD Superseded by 2019-0018
N/A		N/A		N/A - Superseded by FAA AD 2018-10-11
Complied With	Date: 04 Apr 19 ETT: 49,263.58 ETC: 41,644	Terminated		ESN 888473 >30,000 Flight Cycles Fan Blade PN: 340-001-036-0 & 340-001-037-0- Installed C/W by Southwest per SB72-1033
Complied With	Date: 04 Apr 19 ETT: 49,263.58 ETC: 41,644	Terminated		SB 72-1019 C/W by Southwest in accordance with Work Instruction No. 772-21-21 SB 72-1033 C/W by Southwest
N/A		N/A		N/A - Replaced by AD 2018-18-01
N/A		N/A		Superseded by FAA AD 2018-26-01
Complied With	Date: 29 Apr 19 ETT: 49,263.58 ETC: 41,644	Open	ETC: 43,244	C/W At JES Wo.B16809 Fan Blade PN: 340-001-036-0 & PN 340-001-037-0- Installed
Complied With	Date: 29 Apr 19 ETT: 49,263.58 ETC: 41,644	Open	ETC: 43,244	C/W At JES Wo.B16809 Fan Blade PN: 340-001-036-0 & PN 340-001-037-0- Installed
N/A		N/A		Superseded by AD 2019-0150

Airworthiness Directive Status Report

Requirements					
AD Ref	SB Ref/Related Info	Title	Effective Date	Supersedure	Tracked Component
2019-0150	72-1074 R1 (CFM56-5B) 72-0794 R1 (CFM56-5C) 72-1042 R1 (CFM56-7B)	Engine - Rotating Air High Pressure Turbine Front Seal - Replacement	05 Jul 19	Supersedes: 2019-0146 Superseded By: 2020-0007	
2019-12-05	72-1042 R1 (-7B) 72-0794 R1 (-5C) 72-1074 R1 (-5B)	ATA 72 – Engine – Rotating Air High Pressure Turbine Front Seal – Replacement	05 Jul 19		
2020-0007	72-1074 R2 (CFM56-5B) 72-1042 R2 (CFM56-7B) 72-0794 R2 (CFM56-5C) *AD 2019-0146 R0* is linked to SB 72-0794 R1	Engine – Rotating Air High Pressure Turbine Front Seal – Replacement	29 Jan 20	Supersedes: 2019-0150	
2020-0044	72-0952 R1 (CFM56-5B) 72-0796 R1 (CFM56-5C) 72-1054 R1 (CFM56-7B)	Engine - High-Pressure Turbine Inner Stationary Seal – Inspection	17 Mar 20		

Last Accomplishment Data		Next Due Data		Method of Compliance
Status		Status		
N/A		N/A		Superseded by AD 2020-0007
N/A		N/A		N/A to HPT Front Air Seal p/n 2116M20P02 currently installed
N/A		N/A		N/A to HPT Front Air Seal p/n 2116M20P02 currently installed
N/A		N/A		N/A to p/n 1808M56G01 s/n TRIT3212 currently fitted.

Name: _____

Company: _____

Title: _____

Signature: _____

Date: _____



Approved Maintenance Organization Statement

This statement certifies that Virgin Australia & Virgintech are an EASA and/or FAA approved Aircraft Maintenance Organization and is responsible for the Base and Line Maintenance and record keeping for Tigerair Australia.

Virgin Australia & Virgintech technical documentation is therefore considered to be the equivalent of Tigerair Australia technical documentation generated with respect to such Maintenance and records keeping performed for Boeing aircraft engine CFM56-7B26/3 serial number 888473 covering the following period of the Engine’s operation and storage.

Engine status at time of Delivery to Tigerair Australia:

Engine Total Time: 49,263.58 Engine Total Cycles: 41,644 Date: August 28th, 2019

Engine status at time of Cease of operation & Redelivery to Virgin Australia Airlines Pty Ltd/VB LeaseCo Pty Ltd:

Engine Total Time: 50,975.10 Engine Total Cycles: 42,633 Date: 1 July 2020

Signature: _____

Name: Click or tap here to enter text.

Title: Click or tap here to enter text.

Company: Click or tap here to enter text.

Date: Click or tap to enter a date.

Please insert *Operator's* logo

OPERATOR'S COMBINATION STATEMENT

This serves to confirm that during the lease term, operation and redelivery of Engine model CFM56-7B26 serial number 888473 by Tigerair Australia:

- 1) Engine was removed in Serviceable Condition: Yes No
If No, please provide all documentation associated with troubleshooting/work accomplished at removal
- 2) The engine and its installed QEC/EBU were delivered in ETOPS configuration and re-delivered in the same modification standard and compliance as when delivered? Yes No *If No, please provide supporting documentation*
- 3) The engine was operated and maintained at an ETOPS Level in accordance with the current OEM manual revision Yes No N/A *If Not an ETOPS Certified Operator mark N/A*
- 4) Were any Fan Blades replaced during the lease term Yes No
If yes, please provide supporting documentation
- 5) Unscheduled Maintenance and/or Inspections were performed during the lease term: Yes No
If yes, please provide supporting documentation
- 6) Were any Engine Operating Limitations reached and/or exceeded during lease term? Yes No
If yes, please provide supporting documentation
- 7) Did the Engine experience any Abnormal Occurrences during lease term, which includes any exposure to radiation where the engine and/or aircraft it was installed on required decontamination?
Yes No *If yes, please provide supporting documentation*
- 8) Was the Engine ever reported to be operating in an Enhanced Procedures Zone (EPZ) or subject to Volcanic Ash Ingestion during lease term? Yes No
If yes, please provide rectification documentation
- 9) Were any Non-OEM Approved Repairs performed on the Engine or its installed QEC?
Yes No *If yes, please provide supporting documentation*
- 10) Were any Non-OEM approved PMA parts installed and/or or incorporated on the Engine or its installed QEC? Yes No *If yes, please provide supporting documentation*
- 11) Were any Non-Type Certificate Holder part(s) or Non-Type Certificate Holder repaired part(s) designated a "Critical Influencing Part" by the respective Engine Type Certificate Holder's "Instructions for Continued Airworthiness" installed on the Engine?
Yes No *If Yes provide details and supporting documentation*
- 12) The Engine was serviced with the following Oil Type(s): Mobil Jet II during the lease term
- 13) An Oil Analysis report was generated during the lease term. Yes No
If yes, please provide supporting documentation
- 14) The Oil Consumption rate was : 0.25_ Quarts/hr Pints/hr Liters/hr during the lease term

OPERATOR'S COMBINATION STATEMENT cont'd

15) The Engine was operated using TS-1 Fuels and/or Fuel Additives, this includes but not limited to Kathon FP 1.5 biocide treatment. Yes No *If yes, please list fuel and/or additive type and duration/amount*

16) The engine was operated and maintained in accordance with the Engine and Aircraft manufacturer's practices, procedures and approved data and in accordance with the AMM.

Yes No *If No provide details and supporting documentation for any Deviations from the Manufacturer's approved data*

Engine status at time of Delivery to Tigerair Australia:

Engine Total Time: 49,263.58 Engine Total Cycles: 41,644 Date: August 28th, 2019

Engine status at time of Cease of Operation & Redelivery to Virgin Australia Airlines Pty Ltd/VB LeaseCo Pty Ltd:

Engine Total Time: 50975.10 Engine Total Cycles: 42633 Date: 1 July 2020

Signature: _____

Name: Click or tap here to enter text.

Company: Click or tap here to enter text.

Title: Click or tap here to enter text.

Date: Click or tap to enter a date.

(Note - This document should be certified by an authorized person in QA or Engineering)

*To be printed on **VB LeaseCo Pty Ltd** letterhead*

ENGINE COMMERCIAL TRACEABILITY STATEMENT

This statement certifies that Engine Model CFM56-7B26 serial number 888473 had the below status at the time of Lease Commencement to Virgin Australia Airlines Pty Ltd/VB LeaseCo Pty Ltd. ESN 888473 was operated by Tigerair Australia and is being redelivered by Virgin Australia Airlines Pty Ltd/VB LeaseCo Pty Ltd to Willis Engine Structured Trust III with the following Engine Redelivery status.

Engine status at time of Delivery to Virgin Australia Airlines Pty Ltd/VB LeaseCo Pty Ltd:

Engine Total Time: 49,263.58 Engine Total Cycles: 41,644 Date: August 28th, 2019

Engine status at time of Redelivery to Willis Engine Structured Trust III:

Engine Total Time: 50975.10 Engine Total Cycles: 42633 Date: 1 July 2020

Company: _____

Signature: _____

Name: _____

Title: _____

Date: _____

To be printed on *Tigerair Australia* letterhead

CERTIFICATION OF OPERATOR INSTALLATION AND REMOVAL HISTORY

To Whom It May Concern:

This is to certify that CFM56-7B26, ESN 888473, while operated by Tigerair Australia had the following installation and removal history:

A/C Reg	Pos	TAT	TAC	Engine TSN	Engine CSN	Thrust Rating	Date	Install/Removal
VH-VOY	2	55,216.31	19,891	49,263.58	41,644	7B26	September 11 th 2019	Installation
VH-VOY	2	56,928.03	20,880	50,975.10	42,633	7B26	TBD	Cease of operation

* As referenced in the Lease Agreement, the above times are noted in decimals

Company: _____

Signature: _____

Name: _____

Title: _____

Date: _____

(Note - This document should be certified by an authorized person in QA or Engineering)

ESN: 888473

General Engine Info	
Model and tag of engine:	CF85E-7834
Current power rating of engine:	7836
Engine ID:	8134-000
Current TSN of engine:	60,975.10
Current CSN of engine:	42,633



Limiting Part Information			
	Limiting Part	Cycles Remaining	
	7836	LPT Rotor (LPT Rear Frame)	3,399
	7832	LPT Rotor (LPT Rear Frame)	3,399
	7834	LPT Rotor (LPT Rear Frame)	3,399
	7837	LPT Rotor (LPT Rear Frame)	3,399
	7827/281	LPT Rotor (LPT Rear Frame)	3,399
	3C-CatA	Fan Rotor (Fan Shell)	11,359
	3C-CatB	Fan Rotor (Fan Shell)	11,359

Module Name	Name	Part Number	Serial No	Total Hours	Total Cycles	Cycles Used													
						7826	7824	7827	7826	7822	7824	7827	7826	7822	7824	7827	7826	7822	7824
Fan Rotor	Fan Disk	340-000-490-0	DD984837	32,811.10	21,404	4,673	2,659	8,961	0	30,000	30,000	30,000	30,000	8,596	8,596	8,596			
Fan Rotor	Fan Booster Spool	340-000-816-0	PA901721	10,493.10	7,014	989	1,895	4,130	0	23,600	23,600	23,600	23,600	18,586	18,586	18,586			
Fan Rotor	Fan Shell	338-000-414-0	D968385	23,854.10	18,841	989	1,895	4,130	0	30,000	30,000	30,000	30,000	11,359	11,359	11,359			
HPC Rotor	HPC Shd 1-2 Spool	1588M1507	GVNNVDFJ	10,493.10	7,014	989	1,895	4,130	0	20,000	20,000	20,000	20,000	12,886	12,886	12,886			
HPC Rotor	HPC Shd 3 Disk	2116M23P01	XAE04878	10,493.10	7,014	989	1,895	4,130	0	20,000	20,000	20,000	20,000	17,886	17,886	17,886			
HPC Rotor	HPC Shd 4 Spool	2048M26004	GVNNVNCG	10,493.10	7,014	989	1,895	4,130	0	20,000	20,000	20,000	20,000	12,886	12,886	12,886			
HPC Rotor	HPC Fuel Shell	1368M26P03	NCJ22941	10,493.10	7,014	989	1,895	4,130	0	20,000	20,000	20,000	20,000	12,886	12,886	12,886			
HPC Rotor	HPC COP Seal	2116M23P01	GFP41176	10,493.10	7,014	989	1,895	4,130	0	20,000	20,000	20,000	20,000	12,886	12,886	12,886			
HPT Rotor	HPT Disk	1488M43P07	GVNNVA13	10,493.10	7,014	989	1,895	4,130	0	20,000	20,000	20,000	20,000	12,886	12,886	12,886			
HPT Rotor	HPT Front (Inlet)	2116M23P01	TM717788	10,493.10	7,014	989	1,895	4,130	0	20,000	20,000	20,000	20,000	12,886	12,886	12,886			
HPT Rotor	HPT Front Shell	2048M21P03	XAE04869	10,493.10	7,014	989	1,895	4,130	0	20,000	20,000	20,000	20,000	12,886	12,886	12,886			
HPT Rotor	HPT Rear Shell	1668M49P04	TM718132	10,493.10	7,014	989	1,895	4,130	0	20,000	20,000	20,000	20,000	12,886	12,886	12,886			
LPT Rotor	LPT Shd 1 Disk	336-001-804-0	PC154878	10,493.10	7,014	989	1,895	4,130	0	25,000	25,000	25,000	25,000	17,886	17,886	17,886			
LPT Rotor	LPT Shd 2 Disk	336-001-804-0	PA783385	10,493.10	7,014	989	1,895	4,130	0	25,000	25,000	25,000	25,000	17,886	17,886	17,886			
LPT Rotor	LPT Shd 3 Disk	336-002-098-0	PC187016	10,493.10	7,014	989	1,895	4,130	0	25,000	25,000	25,000	25,000	17,886	17,886	17,886			
LPT Rotor	LPT Shd 4 Disk	336-002-098-0	PC729382	10,493.10	7,014	989	1,895	4,130	0	25,000	25,000	25,000	25,000	17,886	17,886	17,886			
LPT Rotor	LPT Rotor Support	340-301-792-0	DM798444	10,493.10	7,014	989	1,895	4,130	0	25,000	25,000	25,000	25,000	17,886	17,886	17,886			
LPT Rotor	LPT Shell	340-074-723-0	PC176110	10,493.10	7,014	989	1,895	4,130	0	25,000	25,000	25,000	25,000	17,886	17,886	17,886			
LPT Rotor	LPT Rear Frame	340-166-206-0	LA08164	50,975.10	42,633	989	37,514	4,130	0	46,032	46,032	46,032	46,032	3,399	3,399	3,399			
LPT Rotor	LPT Case	338-117-485-0	DC722877	39,025.10	26,533	989	1,895	4,130	0	N/A	N/A	N/A	N/A	N/A	N/A	N/A			

Module Name	Name	Part Number	Serial No	Total Hours	Total Cycles	Cycles Used														
						3C-CatA	3C-CatB	7827/281	3C-CatA	3C-CatB	7827/281	3C-CatA	3C-CatB	7827/281	3C-CatA	3C-CatB	7827/281	3C-CatA	3C-CatB	
Fan Rotor	Fan Disk	340-000-490-0	DD984837	32,811.10	21,404	0	0	0	30,000	N/A	N/A	8,596	N/A	N/A						
Fan Rotor	Fan Booster Spool	340-000-816-0	PA901721	10,493.10	7,014	0	0	0	23,600	N/A	N/A	18,586	N/A	N/A						
Fan Rotor	Fan Shell	338-000-414-0	D968385	23,854.10	18,841	0	4,847	8,680	30,000	30,000	30,000	11,359	11,359	11,359						
HPC Rotor	HPC Shd 1-2 Spool	1588M1507	GVNNVDFJ	10,493.10	7,014	0	0	0	20,000	N/A	N/A	12,886	N/A	N/A						
HPC Rotor	HPC Shd 3 Disk	2116M23P01	XAE04878	10,493.10	7,014	0	0	0	20,000	N/A	N/A	12,886	N/A	N/A						
HPC Rotor	HPC Shd 4 Spool	2048M26004	GVNNVNCG	10,493.10	7,014	0	0	0	20,000	N/A	N/A	12,886	N/A	N/A						
HPC Rotor	HPC Fuel Shell	1368M26P03	NCJ22941	10,493.10	7,014	0	0	0	20,000	N/A	N/A	12,886	N/A	N/A						
HPC Rotor	HPC COP Seal	2116M23P01	GFP41176	10,493.10	7,014	0	0	0	20,000	N/A	N/A	12,886	N/A	N/A						
HPT Rotor	HPT Disk	1488M43P07	GVNNVA13	10,493.10	7,014	0	0	0	20,000	N/A	N/A	12,886	N/A	N/A						
HPT Rotor	HPT Front (Inlet)	2116M23P01	TM717788	10,493.10	7,014	0	0	0	20,000	N/A	N/A	12,886	N/A	N/A						
HPT Rotor	HPT Front Shell	2048M21P03	XAE04869	10,493.10	7,014	0	0	0	20,000	N/A	N/A	12,886	N/A	N/A						
HPT Rotor	HPT Rear Shell	1668M49P04	TM718132	10,493.10	7,014	0	0	0	20,000	N/A	N/A	12,886	N/A	N/A						
LPT Rotor	LPT Shd 1 Disk	336-001-804-0	PC154878	10,493.10	7,014	0	0	0	25,000	N/A	N/A	17,886	N/A	N/A						
LPT Rotor	LPT Shd 2 Disk	336-001-804-0	PA783385	10,493.10	7,014	0	0	0	25,000	N/A	N/A	17,886	N/A	N/A						
LPT Rotor	LPT Shd 3 Disk	336-002-098-0	PC187016	10,493.10	7,014	0	0	0	25,000	N/A	N/A	17,886	N/A	N/A						
LPT Rotor	LPT Shd 4 Disk	336-002-098-0	PC729382	10,493.10	7,014	0	0	0	25,000	N/A	N/A	17,886	N/A	N/A						
LPT Rotor	LPT Rotor Support	340-301-792-0	DM798444	10,493.10	7,014	0	0	0	25,000	N/A	N/A	17,886	N/A	N/A						
LPT Rotor	LPT Shell	340-074-723-0	PC176110	10,493.10	7,014	0	0	0	25,000	N/A	N/A	17,886	N/A	N/A						
LPT Rotor	LPT Rear Frame	340-166-206-0	LA08164	50,975.10	42,633	0	0	0	46,032	N/A	N/A	3,399	N/A	N/A						
LPT Rotor	LPT Case	338-117-485-0	DC722877	39,025.10	26,533	19,519	0	0	N/A	N/A	N/A	N/A	N/A	N/A						

Name: _____ Company: _____

Authorizing Signature: _____ Title: _____

Date: _____

To be printed on *Virgin Australia Airlines* letterhead

CERTIFICATION OF OPERATOR INSTALLATION AND REMOVAL HISTORY

To Whom It May Concern:

This is to certify that CFM56-7B26/3, ESN 894902, while operated by Virgin Australia Airlines had the following installation and removal history:

A/C Reg	Pos	TAT	TAC	Engine TSN	Engine CSN	Thrust Rating	Date	Install/Removal
VH-VUT	1	28,773.83	17,712	14,396.37	5,096	7B26/3	October 4 th 2019	Installation
VH-VUT	1	30,086.92	18,479	15,709.45	5,863	7B26/3	TBD	Cease of operation

*** As referenced in the Lease Agreement, the above times are noted in decimals**

Company: _____

Signature: _____

Name: _____

Title: _____

Date: _____

(Note - This document should be certified by an authorized person in QA or Engineering)

ESN: 894902

General Engine info	
Model and type of engine	CFM56-7B27/3
Current power rating of engine	7B26/3
Engine at date:	2-Jul-2020
Current TSN of engine:	15,709.45
Current CSN of engine:	5,863



Limiting Part Information		
Power Rating	Limiting Part	Cycles Remaining
7B20/3	multiple	14,137
7B24/3	multiple	14,137
7B26/3	multiple	14,137
7B27/3	multiple	14,137

LLP Parts

Module Name	Name	Part Number	Serial No	Total Hours	Total Cycles	Cycles Used	Cycles Used	Cycles Used	Cycles Used	Cycles Limit	Cycles Limit	Cycles Limit	Cycles Limit	Cycles Remaining	Cycles Remaining	Cycles Remaining	Cycles Remaining
						7B20/3	7B24/3	7B26/3	7B27/3	7B20/3	7B24/3	7B26/3	7B27/3	7B20/3	7B24/3	7B26/3	7B27/3
Fan Rotor	Fan Disk	340-000-420-0	DD763554	15,709.45	5,863	827	157	4,467	412	30,000	30,000	30,000	30,000	24,137	24,137	24,137	24,137
Fan Rotor	Fan Booster Spool	340-000-816-0	DD975803	15,709.45	5,863	827	157	4,467	412	22,900	22,900	22,900	22,900	17,037	17,037	17,037	17,037
Fan Rotor	Fan Shaft	335-006-414-0	DD935411	15,709.45	5,863	827	157	4,467	412	30,000	30,000	30,000	30,000	24,137	24,137	24,137	24,137
HPC Rotor	HPC Stg 1-2 Spool	1558M31G07	GWN0FTCL	15,709.45	5,863	827	157	4,467	412	20,000	20,000	20,000	20,000	14,137	14,137	14,137	14,137
HPC Rotor	HPC Stg 3 Disk	2116M23P01	XAEK4025	15,709.45	5,863	827	157	4,467	412	20,000	20,000	20,000	20,000	14,137	14,137	14,137	14,137
HPC Rotor	HPC Stg 4-9 Spool	2048M20G03	GWN0FWRR	15,709.45	5,863	827	157	4,467	412	20,000	20,000	20,000	20,000	14,137	14,137	14,137	14,137
HPC Rotor	HPC Fwd Shaft	1386M56P03	GWN0FT4A	15,709.45	5,863	827	157	4,467	412	20,000	20,000	20,000	20,000	14,137	14,137	14,137	14,137
HPC Rotor	HPC CDP Seal	2116M25P01	GFF5DTAM	15,709.45	5,863	827	157	4,467	412	20,000	20,000	20,000	20,000	14,137	14,137	14,137	14,137
HPT Rotor	HPT Disk	1498M43P07	GWN0FRH4	15,709.45	5,863	827	157	4,467	412	20,000	20,000	20,000	20,000	14,137	14,137	14,137	14,137
HPT Rotor	HPT Front Airseal	2116M20P02	GWN0FTC0	15,709.45	5,863	827	157	4,467	412	20,000	20,000	20,000	20,000	14,137	14,137	14,137	14,137
HPT Rotor	HPT Front Shaft	2048M21P03	XAEK5016	15,709.45	5,863	827	157	4,467	412	20,000	20,000	20,000	20,000	14,137	14,137	14,137	14,137
HPT Rotor	HPT Rear Shaft	1864M90P04	TMT4N171	15,709.45	5,863	827	157	4,467	412	20,000	20,000	20,000	20,000	14,137	14,137	14,137	14,137
LPT Rotor	LPT Stg 1 Disk	336-001-804-0	BD021355	15,709.45	5,863	827	157	4,467	412	25,000	25,000	25,000	25,000	19,137	19,137	19,137	19,137
LPT Rotor	LPT Stg 2 Disk	336-001-909-0	BC998705	15,709.45	5,863	827	157	4,467	412	25,000	25,000	25,000	25,000	19,137	19,137	19,137	19,137
LPT Rotor	LPT Stg 3 Disk	336-002-006-0	DD655880	15,709.45	5,863	827	157	4,467	412	25,000	25,000	25,000	25,000	19,137	19,137	19,137	19,137
LPT Rotor	LPT Stg 4 Disk	336-002-105-0	DD935724	15,709.45	5,863	827	157	4,467	412	25,000	25,000	25,000	25,000	19,137	19,137	19,137	19,137
LPT Rotor	LPT Rotor Support	338-077-502-0	BC979758	15,709.45	5,863	827	157	4,467	412	25,000	25,000	25,000	25,000	19,137	19,137	19,137	19,137
LPT Rotor	LPT Shaft	340-074-723-0	DD570630	15,709.45	5,863	827	157	4,467	412	25,000	25,000	25,000	25,000	19,137	19,137	19,137	19,137
LPT Rotor	LPT Rear Frame	340-166-210-0	LA156132	15,709.45	5,863	827	157	4,467	412	25,000	25,000	25,000	25,000	19,137	19,137	19,137	19,137
LPT Rotor	LPT Case	338-117-407-0	DC722804	15,709.45	5,863	827	157	4,467	412	N/L	N/L	N/L	N/L	N/L	N/L	N/L	N/L

Company _____

Signature _____

Name _____

Title _____

Date _____

ESN: 894902

General Engine info	
Model and type of engine	CFM56-7B27/3
Current power rating of engine	7B26/3
Engine at date:	2-Jul-2020
Current TSN of engine:	15,709.45
Current CSN of engine:	5,863

Limiting Part Information		
Power Rating	Limiting Part	Cycles Remaining
7B20/3	multiple	14,137
7B24/3	multiple	14,137
7B26/3	multiple	14,137
7B27/3	multiple	14,137



To be printed on *Virgin Australia Airlines* letterhead

ENGINE CERTIFICATION

This statement certifies that Engine CFM56-7B26/3 serial number 894902, has not been involved in an incident or accident, major failure, or fire, nor has the Engine or the parts installed thereon, been immersed in salt water or exposed to corrosive agents outside normal operation, been subjected to extreme stress or heat nor been obtained from any Government, Military or Unapproved Source while Leased and/or Operated by Virgin Australia Airlines Pty Ltd, and in the case of a part installed on the engine while Leased and/or Operated by Virgin Australia Airlines Pty Ltd, has not been subjected to, or removed from an engine that has been involved in an incident or accident, major failure, or fire, or has been subjected to extreme stress or heat nor been obtained from any Government, Military or Unapproved Source.

No Non-OEM Approved Repairs were performed on the Engine or its installed QEC
No Non-OEM approved PMA parts were installed and/or or incorporated on the Engine or its installed QEC

Engine status at time of Delivery to Virgin Australia Airlines Pty Ltd:

Engine Total Time: 14,396.37 Engine Total Cycles: 5,096 Date: September 13th, 2019

Engine status at time of Cease of operation & Redelivery to VB LeaseCo Pty Ltd:

Engine Total Time: 15709.45 Engine Total Cycles: 5863 Date: 2 July 2020

Company: _____

Signature: _____

Name: _____

Title: _____

Date: _____

(Note - This document should be certified by an authorized person in QA or Engineering)

ESN: 894902

Model/Type(Mark):	CFM56-7B27/3	Data at Date:	02 July 2020
Current Power Rating:	7B26/3	TSN:	15,709.45
		CSN:	5,863

Requirements					
AD Ref	SB Ref/Related Info	Title	Effective Date	Supersedure	Tracked Component
98-14-51 DGAC 98-259(B)R1	72-132, 72-130	Check the AGB and TGB magnetic chip detectors for abnormal magnetic particles	01 Oct 98	Supersedes: T98-14-51	
T98-14-51	72-132, 72-130	Check the AGB and TGB magnetic chip detectors (MCD) for abnormal magnetic particles.	02 Jul 98	Superseded By: 98-14-51 DGAC 98-259(B)R1	
T98-18-51		To prevent an uncommanded engine acceleration event inspect for the presence of engine EEC fault messages for both engines	28 Aug 98	Superseded By: 98-21-23 DGAC 98-350(B)R2	
98-19-20 DGAC 98-162(B)R1	73-016R2	To prevent failure of the HMU overspeed governor (OSG) spool shaft valve inspect the HMU p/n 1853M56P04 (Allied Signal p/n 442008) and 1853M56P05 (Allied Signal p/n 442026)	07 Oct 98		
98-21-11 (Airframe)		To prevent failure of the APU or engine fire detection system to detect a fire in a timely manner, replace affected fire detectors having serial numbers noted in AD	21 Oct 98		
98-21-23 DGAC 98-350(B)R2	73-A024, AOW 98/CFM56/312R1	To prevent an uncommanded engine acceleration event inspect for the presence of engine EEC fault messages for both engines.	02 Nov 98	Supersedes: T98-18-51	
2000-12-01 DGAC 2000-294-IMP(B)		To prevent critical life limited rotating engine part failure	11 Dec 00	Supersedes: 99-08-16 Superseded By: 2002-13-03 DGAC 2002-390-IMP(B)	
2001-02-12 DGAC 2001-057(B)	75-0005	To prevent air leakage from incorrectly torqued fittings of the PS3 pressure line	14 Feb 01		

Last Accomplishment Data		Next Due Data		Method of Compliance
Status		Status		
N/A		N/A		N/A to ESN 894902 & AGB PN: 340-046-504-0, SN: WZ1099 installed
N/A		N/A		N/A - Superseded by AD 98-14-51
N/A		N/A		N/A - Superseded by AD 98-21-23
N/A		N/A		N/A to HMU PN: 442653, SN: BECW5465 installed
N/A		N/A		N/A to Fire Detectors: Left Core PN: 902862, SN: 7027; Right Core PN: 902018-01, SN: 6931; Upper Fan PN: 902864, SN: 6458; Lower Fan PN: 902016-01, SN: 6751 installed.
N/A		N/A		N/A to EEC Software PN: 2044M25P19, Version 7.B.W2F3 (7E6A) installed
N/A		N/A		N/A - Superseded by AD 2002-13-03
N/A		N/A		N/A to ESN 894902

Airworthiness Directive Status Report

Requirements						Last Accomplishment Data		Next Due Data		Method of Compliance
AD Ref	SB Ref/Related Info	Title	Effective Date	Supersedure	Tracked Component	Status		Status		
2010-13-09 EASA AD 2009-0270	CFM56-5B SB 72-0733R1, CFM56-7B SB 72-0743R1	To prevent uncontained failure of the LPT stage 3 disk, replace suspect disks p/n 336-002-006-0 having serial numbers referenced in AD	26 Jul 10		LPT Rotor - LPT Stg 3 Disk 336-002-006-0	N/A		N/A		N/A to LPT Stg. 3 Disk PN: 336-002-006-0, SN: DD655880 installed
2011-18-10 (Airframe)	Boeing ASB 737-71A1462R3	To prevent increased structural loads on the aft engine mount	07 Nov 11	Supersedes: 2003-03-01		Complied With	Date: 04 Oct 19 ETT: 14,396.37 ETC: 5,096	Open		C/W @ Virgin Australia W/O 168912 Aft Mount PN: 310A2031-25, SN: B5826Y installed Inspect Center Link Assembly of Engine Aft Mount for proper installation at each engine installation
2011-18-10 (Airframe) Part 2	Boeing ASB 737-71A1462R3	To prevent increased structural loads on the aft engine mount (Mark the hanger fitting and center link)	07 Nov 11	Supersedes: 2003-03-01		Complied With	Date: 05 May 17 ETT: 10,765.95 ETC: 3,817	Terminated		C/W by KLM on WO #7B/0313401 Aft Mount PN: 310A2031-25, SN: B5826Y installed Inspect Center Link Assembly of Engine Aft Mount for proper installation at each engine installation
2011-18-10 (Airframe) Part 1	Boeing ASB 737-71A1462R3	To prevent increased structural loads on the aft engine mount (Inspection and correction of aft engine mounts)	07 Nov 11	Supersedes: 2003-03-01		Complied With	Date: 04 Oct 19 ETT: 14,396.37 ETC: 5,096	Open		C/W @ Virgin Australia W/O 168912 Aft Mount PN: 310A2031-25, SN: B5826Y installed Inspect Center Link Assembly of Aft Engine Mount for proper installation at each engine installation
2012-05-02 (Airframe)	Boeing SB 737-78-1082	To detect and correct heat damage to the inner wall of the thrust reversers	10 May 12			N/A		N/A		N/A - Thrust Reverser not provided Operator responsible for compliance
2013-08-01 (Airframe)	Boeing SB 737-78-1086R1	To detect and correct damage to the fire seals, perform one-time general visual inspection of the left and right thrust reverser halves	10 Jun 13			N/A		N/A		N/A - Thrust Reverser not provided Operator responsible for compliance
2013-26-01 EASA AD 2012-0209	CFM56-3 SB 72-1129R3, CFM56-7B 72-0564R5, CFM56-7B SB 72-0879R1	To prevent loss of engine oil while in flight, perform repeat inspection of AGB handcranking pad cover and/or replace AGB with an improved AGB	03 Feb 14			Complied With	Date: 13 Apr 18 ETT: 12,069.50 ETC: 4,327	Open		C/W by WAML WO# WP10119 AGB PN: 340-046-504-0, SN: WZ1099 installed After any maintenance that involves the removal and re-installation of the AGB handcracking cover, perform an independent inspection to verify re-installation of the AGB handcracking pad cover Terminating action to the inspection requirement of par(f): Replace the AGB with an AGB that is not listed in par(c). (Install AGB PN 340-046-508-0 or PN 340-046-509-0 IAW SB 72-0564R3 or SB 72-0879R1)

Airworthiness Directive Status Report

Requirements					
AD Ref	SB Ref/Related Info	Title	Effective Date	Supersedure	Tracked Component
2013-26-01 EASA AD 2012-0209 par(f)	CFM56-3 SB 72-1129R2, CFM56-7B 72-0564R5, CFM56-7B SB 72-0879R1	To prevent loss of engine oil while in flight, perform repeat inspection of AGB handcranking pad cover	03 Feb 14		
2013-26-01 EASA AD 2012-0209 par(g)	CFM56-3 SB 72-1129R2, CFM56-7B 72-0564R5, CFM56-7B SB 72-0879R1	To prevent loss of engine oil while in flight, replace AGB with an improved AGB (Terminating Action)	03 Feb 14		
EASA AD 2014-0130	CFM56-5B TR 05-0223, CFM56-7B TR 05-0163	Time Limits - Engine Stationary Parts - Life Limits / Mandatory Inspections	03 Jun 14		
EASA AD 2014-0130	CFM56-5B TR 05-0223, CFM56-7B TR 05-0163	Time Limits - Engine Stationary Parts - Life Limits / Mandatory Inspections	03 Jun 14		
2015-04-02 EASA AD 2014-0261	SB 73-0203 SB 73-0204 EASA AD 2014-0261	EEC Software update to 7.B.W	31 Mar 15		

Last Accomplishment Data		Next Due Data		Method of Compliance
Status		Status		
Complied With	Date: 13 Apr 18 ETT: 12,069.50 ETC: 4,327	Open		C/W by WAML WO# WP10119 AGB PN: 340-046-504-0, SN: WZ1099 installed After any maintenance that involves the removal and re-installation of the AGB handcranking cover, perform an independent inspection to verify re-installation of the AGB handcranking pad cover
Not yet Accomplished		Open		AGB PN: 340-046-504-0, SN: WZ1099 installed Terminating action to the inspection requirement of par(f): Replace the AGB with an AGB that is not listed in par(c). (Install AGB PN 340-046-508-0 or PN 340-046-509-0 IAW SB 72-0564R3 or SB 72-0879R1) NOTE: Reference SBs for industry support claims. Must be submitted within one year of compliance and by December 31, 2016
Complied With	Date: 14 Oct 15 ETT: 8,520.00 ETC: 2,840 PTT: 8,520.00 PTC: 2,840	Open		C/W by KLM on WO #7B/0205013 LPT Rear Frame PN: 340-166-210-0, SN: LA156132 installed Engine / LLP has operated at a model configuration (thrust rating) with a life limit. Remaining life is currently calculated per TR 05-0163. Reference LLP Status for life remaining If engine / LLP operates at a model configuration (thrust rating) without a life limit or on condition limit, remaining life must be calculated per TR 05-0163 or later approved revision Review at each thrust rating change
Complied With	Date: 14 Oct 15 ETT: 8,520.00 ETC: 2,840 PTT: 8,520.00 PTC: 2,840	Open		C/W by KLM on WO #7B/0205013 LPT Case PN: 338-117-407-0, SN: DC722804 installed Engine / LLP has not operated at a model configuration (thrust rating) with a life limit or on condition limit. Calculation of remaining life is not required If engine / LLP operates at a model configuration (thrust rating) with a life limit or on condition limit, remaining life must be calculated per TR 05-0163 or later approved revision Review at each thrust rating change
Complied With	Date: 26 Jun 19 ETT: 14,396.37 ETC: 5,096	Terminated		C/W - EEC P/N: 2042M67P04 S/N FFFB4986 w/ software P/N 2044M25P19, 7E6A (7.B.W2F3) installed

Airworthiness Directive Status Report

Requirements					
AD Ref	SB Ref/Related Info	Title	Effective Date	Supersedure	Tracked Component
2015-18-04 EASA AD 2015-0133	CFM56-7B SB 72-0964 CFM56-7B SB 72-0965 AOW 15-CFM56-730 - States that 100% of affected gearshafts have been located and removed from service.	Accessory Gearbox Gearshaft - Inspection / replacement of affected 41-tooth AGB gearshaft P/N 335-303-002-0 and 73-tooth AGB gearshaft P/N 335-302-902-0 installed on CFM56-7B engines. Note: From effective date do not install any affected gearshafts identified in appendix 1 & 2 of EASA AD 2015-0133 on any CFM56-3 or CFM56-7B engine.	22 Jul 15		
2018-0071	72-1019 R1 72-1024	Engine - Fan Blades – Inspection	02 Apr 18	Superseded By: 2018-0093-E	
2018-0093-E	72-1033 EASA Emergency AD 2018-0093-E AMOC (1 & 2) FAA AD 2018-09-51-E FAA AD 2018-09-51-E (AMOC 1, 2 & 3) FAA AD 22018-09-10	Engine - Fan Blades - Inspection	20 Apr 18	Supersedes: 2018-0071 Superseded By: 2018-0109	
2018-0109	72-1033 R1 FAA AD 2018-10-11	Engine - Fan Blades - Inspection	18 May 18	Supersedes: 2018-0093-E Superseded By: 2018-0211	
2018-0211	SB 72-1033 R2	Engine - Fan Blades – Inspection	05 Oct 18	Supersedes: 2018-0109 Superseded By: 2019-0018	
2018-09-10	EASA AD 2018-0093-E FAA AD 2018-09-51-E AMOC to FAA AD 2018-09-10 SB 72-1033	Engine - Fan Blades - Inspection	14 May 18	Superseded By: 2018-10-11	
2018-09-51-E	FAA EAD 2018-09-51-E AMOC (1, 2 & 3) EASA EAD 2018-0093 EASA 2018-0093-E AMOC (1 & 2) SB 72-1033	Engine - Fan Blades - Inspection	20 Apr 18		
2018-09-51	FAA AD 2018-10-11 FAA EAD 2018-09-51-E EASA AD 2018-0109 SB 72-1033 R1	Engine - Fan Blades - Inspection	07 Jun 18		

Last Accomplishment Data		Next Due Data		Method of Compliance
Status		Status		
N/A		N/A		N/A to ESN 894902; AGB PN: 340-046-504-0, SN: WZ1099; 41-Tooth Gearshaft PN: 335-303-002-0, SN: EB495982 & 73-Tooth Gearshaft PN: 335-302-902-0, SN: EB491294 installed
N/A		N/A		N/A - Superseded by AD 2018-0093-E.
N/A		N/A		N/A - Superseded by AD 2018-0109
N/A		N/A		N/A - Superseded by AD 2018-0211
N/A		N/A		N/A - Superseded by AD 2019-0018
N/A		N/A		N/A - Superseded by FAA AD 2018-10-11
N/A		N/A		N/A - Engine has not operated more than 30,000 Flight Cycles at issuance of AD 2018-09-51-E
N/A		N/A		N/A - Engine has not operated more than 30,000 Flight Cycles

Airworthiness Directive Status Report

Requirements					
AD Ref	SB Ref/Related Info	Title	Effective Date	Supersedure	Tracked Component
2001-11-05 DGAC 2001-240(B)		To prevent #4 Bearing failures. Applicable to installed P/N 305-355-717-0 only.	11 Jun 01		
2002-13-03 DGAC 2002-390-IMP(B)		To prevent critical life-limited rotating engine part failure.	01 Aug 02	Supersedes: 2000-12-01 DGAC 2000-294-IMP(B)	
2002-14-21 (Airframe)	Boeing 737-73A1011R2	To prevent major fuel leakage due to excessive wear of the quick-disconnect coupling on the fuel hose	21 Aug 02	Supersedes: 99-03-08	
2002-16-18 DGAC 2002-470(B)	72-0241R1	To aid in containment of the LPT rotor in the event of LPT shaft failure	18 Sep 02		
2003-03-01 (Airframe)	Boeing ASB 737-71A1462R1	To prevent increased structural loads on the aft engine mount	13 Feb 03	Superseded By: 2011-18-10 (Airframe)	
2003-03-01 (Airframe) Part 1	Boeing ASB 737-71A1462R1	To prevent increased structural loads on the aft engine mount (Inspection and correction of aft engine mounts)	13 Feb 03	Superseded By: 2011-18-10 (Airframe) Part 1	
2003-03-01 (Airframe) Part 2	Boeing ASB 737-71A1462R1	To prevent increased structural loads on the aft engine mount (Mark the hanger fitting and center link)	13 Feb 03	Superseded By: 2011-18-10 (Airframe) Part 2	
2006-26-01		To prevent the loss of engine thrust that could result in loss of control during takeoff or landing. Do not install certain Western Filter or PTI Technologies fuel filter p/ns.	17 Jan 07		
2008-03-09 EASA AD 2007-0104	72-0579R8 (rev date: 1-25-2012)	To prevent failure of the TRF from low-cycle fatigue cracks (LPT rear frame inspection limits)	10 Mar 08		LPT Rotor - LPT Rear Frame 340-166-210-0
2009-11-02		To prevent cracking of the HPC 4-9 spools that Propulsion Technology LLC improperly repaired and returned to service	23 Jun 09		HPC Rotor - HPC Stg 4-9 Spool
2010-01-05 EASA AD 2009-0009	72-0579R8 , 72-0558R4	To prevent failure of the LPT rear frame from low-cycle fatigue cracks	18 Feb 10		LPT Rotor - LPT Rear Frame

Last Accomplishment Data		Next Due Data		Method of Compliance
Status		Status		
N/A		N/A		N/A to ESN 894902 & #4 Roller Bearing PN: 305-355-718-0, SN: DD567100 installed
Not yet Accomplished		Open		Inspect at next piece-part exposure
N/A		N/A		N/A - Fuel Supply Hose PN: AE713733-1 (with B-nut connectors) installed
N/A		N/A		N/A per EDS dated 9/18/2007
N/A		N/A		N/A - Superseded by AD 2011-18-10
N/A		N/A		N/A - Superseded by AD 2011-18-10
N/A		N/A		N/A - Superseded by AD 2011-18-10
Complied With	Date: 18 Jul 19 ETT: 14,396.37 ETC: 5,096	Open		C/W by WAML WO# WP10366 Fuel Filter P/N CA01962B installed At each fuel filter replacement, ensure that PMA fuel filters are NOT used Note: Can be accomplished In-Shop or On-Wing
N/A		N/A		N/A to engine model
N/A		N/A		N/A to HPC Stg. 4-9 Spool PN: 2048M20G03, SN: GWN0FWRR installed
N/A		N/A		N/A to LPT Rear Frame PN: 340-166-210-0, SN: LA156132 installed

Airworthiness Directive Status Report

Requirements					
AD Ref	SB Ref/Related Info	Title	Effective Date	Supersedure	Tracked Component
2018-10-11	72-1033 R1 EASA AD 2018-0109	Engine - Fan Blades - Inspection	01 Jun 18	Supersedes: 2018-09-10 Superseded By: 2018-18-01	
2018-18-01	EASA AD 2018-0211 SB 72-1033 R2	Engine - Fan Blades - Inspection	16 Oct 18	Supersedes: 2018-10-11 Superseded By: 2018-26-01	
2018-26-01	72-1033 R3	ATA 72 - Engine - Fan Blades - Inspection	10 Jan 19	Supersedes: 2018-18-01	
2019-0018	Refer to FAA AD 2018-26-01 Refer to SB 72-1033 R3	Engine - Fan Blades - Inspection	13 Feb 19	Supersedes: 2018-0211	
2019-0146	72-1074 R1 (-5B) 72-0794 R1 (-5C) 72-1042 R1 (-7B)	ATA 72 - Engine - Rotating Air High Pressure Turbine Front Seal - Replacement	28 Jun 19	Superseded By: 2019-0150	
2019-0150	72-1074 R1 (CFM56-5B) 72-0794 R1 (CFM56-5C) 72-1042 R1 (CFM56-7B)	Engine - Rotating Air High Pressure Turbine Front Seal - Replacement	05 Jul 19	Supersedes: 2019-0146 Superseded By: 2020-0007	
2019-12-05	72-1042 R1 (-7B) 72-0794 R1 (-5C) 72-1074 R1 (-5B)	ATA 72 - Engine - Rotating Air High Pressure Turbine Front Seal - Replacement	05 Jul 19		

Last Accomplishment Data		Next Due Data		Method of Compliance
Status		Status		
N/A		N/A		N/A - Replaced by AD 2018-18-01
N/A		N/A		N/A - Superseded by AD 2018-26-01
Complied With	Date: 12 Jul 19 ETT: 14,396.33 ETC: 5,096	Open	ETC: 17,000	CW @ WAML WO# WP10366 Fan Blade PN installed: 20 x 340-001-026-0 (original from eng manufacture) 02 x 340-001-027-0 02 x 340-001-036-0 C/W SB 72-1033 at WAML WO# WP10366 dated 7/12/2019 on fan blades P/N 340-001-027-0 S/N BB083064-C, P/N 340-001-027-0 S/N BB074609-K. Fan blades installed overhauled at Transavia dated 5/21/2007. TSN/CSN: UNK Fan Blades P/N 340-001-036-0 S/N PC384132-L, P/N 340-001-036-0 S/N PC331389-F installed NEW at Transavia dated 7/30/2016.
Complied With	Date: 12 Jul 19 ETT: 14,396.33 ETC: 5,096	Open	ETC: 6,696	CW @ WAML WO# WP10366 Fan Blade PN installed: 20 x 340-001-026-0 (original from eng manufacture) 02 x 340-001-027-0 02 x 340-001-036-0 C/W SB 72-1033 at WAML WO# WP10366 dated 7/12/2019 on fan blades P/N 340-001-027-0 S/N BB083064-C, P/N 340-001-027-0 S/N BB074609-K. Fan blades installed overhauled at Transavia dated 5/21/2007. TSN/CSN: UNK Fan Blades P/N 340-001-036-0 S/N PC384132-L, P/N 340-001-036-0 S/N PC331389-F installed NEW at Transavia dated 7/30/2016.
N/A		N/A		N/A - Superseded by AD 2019-0150
N/A		N/A		N/A - Superseded By AD 2020-0007
N/A		N/A		N/A to Rotating Air High Pressure Turbine Front Seal P/N 2116M20P02 S/N GWN0FTC0 installed

Airworthiness Directive Status Report

Requirements					
AD Ref	SB Ref/Related Info	Title	Effective Date	Supersedure	Tracked Component
2020-0007	72-1074 R2 (CFM56-5B) 72-1042 R2 (CFM56-7B) 72-0794 R2 (CFM56-5C) *AD 2019-0146 R0* is linked to SB 72-0794 R1	Engine – Rotating Air High Pressure Turbine Front Seal – Replacement	29 Jan 20	Supersedes: 2019-0150	
2020-0044	72-0952 R1 (CFM56-5B) 72-0796 R1 (CFM56-5C) 72-1054 R1 (CFM56-7B)	Engine - High-Pressure Turbine Inner Stationary Seal – Inspection	17 Mar 20		

Last Accomplishment Data		Next Due Data		Method of Compliance
Status		Status		
N/A		N/A		N/A to Rotating Air High Pressure Turbine Front Seal P/N 2116M20P02 S/N GWN0FTC0 installed
N/A		N/A		N/A to HPT Inner Stationary Seal P/N 1808M56G01 S/N ALFNB100

Name: _____

Company: _____

Title: _____

Signature: _____

Date: _____

OPERATOR'S COMBINATION STATEMENT

This serves to confirm that during the lease term, operation and redelivery of Engine model CFM56-7B26/3 serial number 894902 by Virgin Australia Airlines:

- 1) Engine was removed in Serviceable Condition: Yes No
If No, please provide all documentation associated with troubleshooting/work accomplished at removal
- 2) The engine and its installed QEC/EBU were delivered in ETOPS configuration and re-delivered in the same modification standard and compliance as when delivered? Yes No *If No, please provide supporting documentation*
- 3) The engine was operated and maintained at an ETOPS Level in accordance with the current OEM manual revision Yes No N/A *If Not an ETOPS Certified Operator mark N/A*
- 4) Were any Fan Blades replaced during the lease term Yes No
If yes, please provide supporting documentation
- 5) Unscheduled Maintenance and/or Inspections were performed during the lease term: Yes No
If yes, please provide supporting documentation
- 6) Were any Engine Operating Limitations reached and/or exceeded during lease term? Yes No
If yes, please provide supporting documentation
- 7) Did the Engine experience any Abnormal Occurrences during lease term, which includes any exposure to radiation where the engine and/or aircraft it was installed on required decontamination?
Yes No *If yes, please provide supporting documentation*
- 8) Was the Engine ever reported to be operating in an Enhanced Procedures Zone (EPZ) or subject to Volcanic Ash Ingestion during lease term? Yes No
If yes, please provide rectification documentation
- 9) Were any Non-OEM Approved Repairs performed on the Engine or its installed QEC?
Yes No *If yes, please provide supporting documentation*
- 10) Were any Non-OEM approved PMA parts installed and/or or incorporated on the Engine or its installed QEC? Yes No *If yes, please provide supporting documentation*
- 11) Were any Non-Type Certificate Holder part(s) or Non-Type Certificate Holder repaired part(s) designated a "Critical Influencing Part" by the respective Engine Type Certificate Holder's "Instructions for Continued Airworthiness" installed on the Engine?
Yes No *If Yes provide details and supporting documentation*
- 12) The Engine was serviced with the following Oil Type(s): Mobil Jet II during the lease term
- 13) An Oil Analysis report was generated during the lease term. Yes No
If yes, please provide supporting documentation
- 14) The Oil Consumption rate was : 0.24 Quarts/hr Pints/hr Liters/hr during the lease term

OPERATOR'S COMBINATION STATEMENT cont'd

15) The Engine was operated using TS-1 Fuels and/or Fuel Additives, this includes but not limited to Kathon FP 1.5 biocide treatment. Yes No *If yes, please list fuel and/or additive type and duration/amount*

16) The engine was operated and maintained in accordance with the Engine and Aircraft manufacturer's practices, procedures and approved data and in accordance with the AMM.

Yes No *If No provide details and supporting documentation for any Deviations from the Manufacturer's approved data*

Engine status at time of Delivery to Virgin Australia Airlines Pty Ltd:

Engine Total Time: 14,396.37 Engine Total Cycles: 5,096 Date: September 13th, 2019

Engine status at time of Cease of operation & Redelivery to VB LeaseCo Pty Ltd:

Engine Total Time: 15709.45 Engine Total Cycles: 5863 Date: 2 July 2020

Signature: _____

Name: Click or tap here to enter text.

Company: Click or tap here to enter text.

Title: Click or tap here to enter text.

Date: Click or tap to enter a date.

(Note - This document should be certified by an authorized person in QA or Engineering)

*To be printed on **VB LeaseCo Pty Ltd** letterhead*

ENGINE COMMERCIAL TRACEABILITY STATEMENT

This statement certifies that Engine Model CFM56-7B26/3 serial number 894902 had the below status at the time of Lease Commencement to Virgin Australia Airlines Pty Ltd/VB LeaseCo Pty Ltd. ESN 894902 was operated by Virgin Australia Airlines Pty Ltd and is being redelivered by VB LeaseCo Pty Ltd to Willis Engine Structured Trust III with the following Engine Redelivery status.

Engine status at time of Delivery to VB LeaseCo Pty Ltd:

Engine Total Time: 14,396.37 Engine Total Cycles: 5,096 Date: September 13th, 2019

Engine status at time of Redelivery to Willis Engine Structured Trust III:

Engine Total Time: 15,709.45 Engine Total Cycles: 5863 Date: 2 July 2020

Company: _____

Signature: _____

Name: _____

Title: _____

Date: _____

To be printed on *Virgin Australia Airlines* letterhead

ENGINE CERTIFICATION

This statement certifies that Engine CFM56-7B26/3 serial number 896999, has not been involved in an incident or accident, major failure, or fire, nor has the Engine or the parts installed thereon, been immersed in salt water or exposed to corrosive agents outside normal operation, been subjected to extreme stress or heat nor been obtained from any Government, Military or Unapproved Source while Leased and/or Operated by Virgin Australia Airlines Pty Ltd, and in the case of a part installed on the engine while Leased and/or Operated by Virgin Australia Airlines Pty Ltd, has not been subjected to, or removed from an engine that has been involved in an incident or accident, major failure, or fire, or has been subjected to extreme stress or heat nor been obtained from any Government, Military or Unapproved Source.

No Non-OEM Approved Repairs were performed on the Engine or its installed QEC
No Non-OEM approved PMA parts were installed and/or or incorporated on the Engine or its installed QEC

Engine status at time of Delivery to Virgin Australia Airlines Pty Ltd:

Engine Total Time: 19,251.53 Engine Total Cycles: 8,413 Date: June 14th, 2019

Engine status at time of Cease of Operation & redelivery to VB LeaseCo Pty Ltd:

Engine Total Time: 21823.62 Engine Total Cycles: 9801 Date: 2 July 2020

Company: _____

Signature: _____

Name: _____

Title: _____

Date: _____

(Note - This document should be certified by an authorized person in QA or Engineering)

Airworthiness Directive Status Report



ESN: 896999

Model/Type(Mark):	CFM56-7B24/3	Data at Date:	08 Jul 2020
Current Power Rating:	7B26/3	TSN:	21,823.62
Current Location:	VH-VOT/Engine 2	CSN:	9,801

Requirements					
AD Ref	SB Ref/Related Info	Title	Effective Date	Supersedure	Tracked Component
98-14-51 DGAC 98-259(B)R1	72-132, 72-130	Check the AGB and TGB magnetic chip detectors for abnormal magnetic particles	01 Oct 98	Supersedes: T98-14-51	
T98-14-51	72-132, 72-130	Check the AGB and TGB magnetic chip detectors (MCD) for abnormal magnetic particles.	02 Jul 98	Superseded By: 98-14-51 DGAC 98-259(B)R1	
T98-18-51		To prevent an uncommanded engine acceleration event inspect for the presence of engine EEC fault messages for both engines	28 Aug 98	Superseded By: 98-21-23 DGAC 98-350(B)R2	
98-19-20 DGAC 98-162(B)R1	73-016R2	To prevent failure of the HMU overspeed governor (OSG) spool shaft valve inspect the HMU p/n 1853M56P04 (Allied Signal p/n 442008) and 1853M56P05 (Allied Signal p/n 442026)	07 Oct 98		
98-21-11 (Airframe)		To prevent failure of the APU or engine fire detection system to detect a fire in a timely manner, replace affected fire detectors having serial numbers noted in AD	21 Oct 98		
98-21-23 DGAC 98-350(B)R2	73-A024, AOW 98/CFM56/312R1	To prevent an uncommanded engine acceleration event inspect for the presence of engine EEC fault messages for both engines.	02 Nov 98	Supersedes: T98-18-51	
2000-12-01 DGAC 2000-294-IMP(B)		To prevent critical life limited rotating engine part failure	11 Dec 00	Supersedes: 99-08-16 Superseded By: 2002-13-03 DGAC 2002-390-IMP(B)	
2001-02-12 DGAC 2001-057(B)	75-0005	To prevent air leakage from incorrectly torqued fittings of the PS3 pressure line	14 Feb 01		

Last Accomplishment Data		Next Due Data		Method of Compliance
Status		Status		
N/A		N/A		N/A to AGB Starter Gearshaft p/n 340-154-301-0, s/n EB596819 installed per EDS dated 3/24/09
N/A		N/A		N/A - Superseded by AD 98-14-51
N/A		N/A		N/A - Superseded by AD 98-21-23
N/A		N/A		N/A to HMU p/n 1853M56P14 s/n BECW0406 installed
N/A		N/A		N/A to Fire Detectors installed
N/A		N/A		N/A to EEC Software p/n 1853M78P39, Version 7.B.W2F2 (7BA5) installed, as per Delta Tech Ops WO #96761-01 installed 13th April 2015.
N/A		N/A		N/A - Superseded by AD 2002-13-03
N/A		N/A		N/A to ESN 896999

Airworthiness Directive Status Report



Requirements					
AD Ref	SB Ref/Related Info	Title	Effective Date	Supersedure	Tracked Component
2001-11-05 DGAC 2001-240(B)		To prevent #4 Bearing failures. Applicable to installed P/N 305-355-717-0 only.	11 Jun 01		
2002-13-03 DGAC 2002-390-IMP(B)		To prevent critical life-limited rotating engine part failure.	01 Aug 02	Supersedes: 2000-12-01 DGAC 2000-294-IMP(B)	
2002-14-21 (Airframe)	Boeing 737-73A1011R2	To prevent major fuel leakage due to excessive wear of the quick-disconnect coupling on the fuel hose	21 Aug 02	Supersedes: 99-03-08	
2002-16-18 DGAC 2002-470(B)	72-0241R1	To aid in containment of the LPT rotor in the event of LPT shaft failure	18 Sep 02		
2003-03-01 (Airframe)	Boeing ASB 737-71A1462R1	To prevent increased structural loads on the aft engine mount	13 Feb 03	Superseded By: 2011-18-10 (Airframe)	
2003-03-01 (Airframe) Part 1	Boeing ASB 737-71A1462R1	To prevent increased structural loads on the aft engine mount (Inspection and correction of aft engine mounts)	13 Feb 03	Superseded By: 2011-18-10 (Airframe) Part 1	
2003-03-01 (Airframe) Part 2	Boeing ASB 737-71A1462R1	To prevent increased structural loads on the aft engine mount (Mark the hanger fitting and center link)	13 Feb 03	Superseded By: 2011-18-10 (Airframe) Part 2	
2006-26-01		To prevent the loss of engine thrust that could result in loss of control during takeoff or landing. Do not install certain Western Filter or PTI Technologies fuel filter p/ns.	17 Jan 07		
2008-03-09 EASA AD 2007-0104	72-0579R8 (rev date: 1-25-2012)	To prevent failure of the TRF from low-cycle fatigue cracks (LPT rear frame inspection limits)	10 Mar 08		LPT Rotor - LPT Rear Frame
2009-11-02		To prevent cracking of the HPC 4-9 spools that Propulsion Technology LLC improperly repaired and returned to service	23 Jun 09		HPC Rotor - HPC Stg 4-9 Spool
2010-01-05 EASA AD 2009-0009	72-0579R8 , 72-0558R4	To prevent failure of the LPT rear frame from low-cycle fatigue cracks	18 Feb 10		LPT Rotor - LPT Rear Frame

Last Accomplishment Data		Next Due Data		Method of Compliance
Status		Status		
N/A		N/A		N/A to ESN 896999 and #4 Roller Bearing p/n 340-167-902-0, s/n DD336148 installed
Not yet Accomplished		Open		Inspect at next piece part exposure
N/A		N/A		N/A due to Fuel Supply Hose p/n AE713733-1 (with B-nut connectors) installed
N/A		N/A		N/A to LPT Stg 2 Nozzle Segment p/n 338-109-109-0 and p/n 338-109-309-0 and LPT Stg 3 p/n 338-109-704-0 and p/n 338-109-804-0 installed
N/A		N/A		N/A - Superseded by AD 2011-18-10
N/A		N/A		N/A - Superseded by AD 2011-18-10
N/A		N/A		N/A - Superseded by AD 2011-18-10
Complied With	Date: 12 Mar 20 ETT: 21,716.28 ETC: 9,747	Open		C/W at VOZ refer to Maintenance Log# MV755035
N/A		N/A		N/A to LPT Rear Frame p/n 340-166-211-0 s/n DE049945 installed
N/A		N/A		N/A to HPC Stg 4-9 Spool p/n 2048M20G03 s/n GWN0K7KE installed
N/A		N/A		N/A to LPT Rear Frame p/n 340-166-211-0 s/n DE049945 installed

Airworthiness Directive Status Report



Requirements						Last Accomplishment Data		Next Due Data		Method of Compliance
AD Ref	SB Ref/Related Info	Title	Effective Date	Supersedure	Tracked Component	Status		Status		
2010-13-09 EASA AD 2009-0270	CFM56-5B SB 72-0733R1, CFM56-7B SB 72-0743R1	To prevent uncontained failure of the LPT stage 3 disk, replace suspect disks p/n 336-002-006-0 having serial numbers referenced in AD	26 Jul 10		LPT Rotor - LPT Stg 3 Disk 336-002-006-0	N/A		N/A		N/A to ESN 896999 and LPT Stg 3 Disk p/n 336-002-006-0 s/n PA212682 installed
2011-18-10 (Airframe)	Boeing ASB 737-71A1462R3	To prevent increased structural loads on the aft engine mount	07 Nov 11	Supersedes: 2003-03-01		Complied With	Date: 08 Feb 20 ETT: 21,439.75 ETC: 9,601	Open		C/W at engine installation per VA WO174713 Aft Mount p/n 310A2030-17 s/n B6095 installed Inspect center link assy of aft engine mount for proper installation at each engine installation.
2011-18-10 (Airframe) Part 2	Boeing ASB 737-71A1462R3	To prevent increased structural loads on the aft engine mount (Mark the hanger fitting and center link)	07 Nov 11	Supersedes: 2003-03-01		Complied With	Date: 26 Mar 09	Terminated		C/W - Verified during QEC installation at Boeing. Mount is properly marked.
2011-18-10 (Airframe) Part 1	Boeing ASB 737-71A1462R3	To prevent increased structural loads on the aft engine mount (Inspection and correction of aft engine mounts)	07 Nov 11	Supersedes: 2003-03-01		Complied With	Date: 08 Feb 20 ETT: 21,439.75 ETC: 9,601	Open		C/W at engine installation per VA WO174713 Aft Mount p/n 310A2030-17 s/n B6095 installed Inspect center link assy of aft engine mount for proper installation at each engine installation.
2012-05-02 (Airframe)	Boeing SB 737-78-1082	To detect and correct heat damage to the inner wall of the thrust reversers	10 May 12			N/A		N/A		N/A due to Thrust Reverser is NOT provided
2013-08-01 (Airframe)	Boeing SB 737-78-1086R1	To detect and correct damage to the fire seals, perform one-time general visual inspection of the left and right thrust reverser halves	10 Jun 13			N/A		N/A		N/A due to Thrust reverser halves are NOT provided
2013-26-01 EASA AD 2012-0209	CFM56-3 SB 72-1129R3, CFM56-7B 72-0564R5, CFM56-7B SB 72-0879R1	To prevent loss of engine oil while in flight, perform repeat inspection of AGB handranking pad cover and/or replace AGB with an improved AGB	03 Feb 14			N/A		N/A		N/A to AGB installed PN: 340-046-509-0 SN: WQ1059 - Installed
2013-26-01 EASA AD 2012-0209 par(g)	CFM56-3 SB 72-1129R2, CFM56-7B 72-0564R5, CFM56-7B SB 72-0879R1	To prevent loss of engine oil while in flight, replace AGB with an improved AGB (Terminating Action)	03 Feb 14			Complied With	Date: 31 Jan 18 ETT: 15,827.28 ETC: 6,194	Terminated		SB 72-0879 R5 C/W at StandardAero WO# YM351722 AGB PN: 340-046-509-0 SN: WQ1059 - Installed
2013-26-01 EASA AD 2012-0209 par(f)	CFM56-3 SB 72-1129R2, CFM56-7B 72-0564R5, CFM56-7B SB 72-0879R1	To prevent loss of engine oil while in flight, perform repeat inspection of AGB handranking pad cover	03 Feb 14			N/A		N/A		N/A to AGB installed PN: 340-046-509-0 SN: WQ1059 - Installed
EASA AD 2014-0130	CFM56-5B TR 05-0223, CFM56-7B TR 05-0163	Time Limits - Engine Stationary Parts - Life Limits / Mandatory Inspections	03 Jun 14			Open		Open		If engine / LLP operates at a model configuration (thrust rating) without a life limit or on-condition limit, remaining life must be calculated per TR 05-0223 or later approved revision.

Airworthiness Directive Status Report



Requirements					
AD Ref	SB Ref/Related Info	Title	Effective Date	Supersedure	Tracked Component
2015-04-02 EASA AD 2014-0261	SB 73-0203 SB 73-0204 EASA AD 2014-0261	EEC Software update to 7.B.W	31 Mar 15		
2015-18-04 EASA AD 2015-0133	CFM56-7B SB 72-0964 CFM56-7B SB 72-0965 AOW 15-CFM56-730 - States that 100% of affected gearshafts have been located and removed from service.	Accessory Gearbox Gearshaft - Inspection / replacement of affected 41-tooth AGB gearshaft P/N 335-303-002-0 and 73-tooth AGB gearshaft P/N 335-302-902-0 installed on CFM56-7B engines. Note: From effective date do not install any affected gearshafts identified in appendix 1 & 2 of EASA AD 2015-0133 on any CFM56-3 or CFM56-7B engine.	22 Jul 15		
2018-0071	72-1019 R1 72-1024	Engine - Fan Blades – Inspection	02 Apr 18	Superseded By: 2018-0093-E	
2018-0093-E	72-1033 EASA Emergency AD 2018-0093-E AMOC (1 & 2) FAA AD 2018-09-51-E FAA AD 2018-09-51-E (AMOC 1, 2 & 3) FAA AD 22018-09-10	Engine - Fan Blades - Inspection	20 Apr 18	Supersedes: 2018-0071 Superseded By: 2018-0109	
2018-0109	72-1033 R1 FAA AD 2018-10-11	Engine - Fan Blades - Inspection	18 May 18	Supersedes: 2018-0093-E Superseded By: 2018-0211	
2018-0211	SB 72-1033 R2	Engine - Fan Blades – Inspection	05 Oct 18	Supersedes: 2018-0109 Superseded By: 2019-0018	
2018-09-10	EASA AD 2018-0093-E FAA AD 2018-09-51-E AMOC to FAA AD 2018-09-10 SB 72-1033	Engine - Fan Blades - Inspection	14 May 18	Superseded By: 2018-10-11	
2018-09-51-E	FAA EAD 2018-09-51-E AMOC (1, 2 & 3) EASA EAD 2018-0093 EASA 2018-0093-E AMOC (1 & 2) SB 72-1033	Engine - Fan Blades - Inspection	20 Apr 18		

Last Accomplishment Data		Next Due Data		Method of Compliance
Status		Status		
Complied With	Date: 13 Apr 15 ETT: 7,478.15 ETC: 3,161	Terminated		C/W on EEC Software p/n 1853M78P37 (Version 7.B.WF2) installed at Delta Tech Ops WO# 96761-01
N/A		N/A		N/A to ESN 896999, AGB PN: 340-046-509-0 SN: WQ1059 - Installed
N/A		N/A		N/A - Superseded by AD 2018-0093-E
N/A		N/A		N/A - Superseded by AD 2018-0109
N/A		N/A		N/A - Superseded by AD 2018-0211
N/A		N/A		N/A - Superseded by AD 2019-0018
N/A		N/A		N/A - Superseded by AD 2018-10-11
N/A		N/A		N/A - Engine has not operated more than 30,000 Flight Cycles at issuance of AD 2018-09-51-E

Airworthiness Directive Status Report



Requirements					
AD Ref	SB Ref/Related Info	Title	Effective Date	Supersedure	Tracked Component
2018-09-51	FAA AD 2018-10-11 FAA EAD 2018-09-51-E EASA AD 2018-0109 SB 72-1033 R1	Engine - Fan Blades - Inspection	07 Jun 18		
2018-10-11	72-1033 R1 EASA AD 2018-0109	Engine - Fan Blades - Inspection	01 Jun 18	Supersedes: 2018-09-10 Superseded By: 2018-18-01	
2018-18-01	EASA AD 2018-0211 SB 72-1033 R2	Engine - Fan Blades - Inspection	16 Oct 18	Supersedes: 2018-10-11 Superseded By: 2018-26-01	
2018-26-01	72-1033 R3	ATA 72 - Engine - Fan Blades - Inspection	10 Jan 19	Supersedes: 2018-18-01	
2019-0018	Refer to FAA AD 2018-26-01 Refer to SB 72-1033 R3	Engine - Fan Blades – Inspection	13 Feb 19	Supersedes: 2018-0211	
2019-0146	72-1074 R1 (-5B) 72-0794 R1 (-5C) 72-1042 R1 (-7B)	ATA 72 – Engine – Rotating Air High Pressure Turbine Front Seal – Replacement	28 Jun 19	Superseded By: 2019-0150	

Last Accomplishment Data		Next Due Data		Method of Compliance
Status		Status		
N/A		N/A		N/A - Engine has not operated more than 30,000 Flight Cycles
N/A		N/A		N/A - Superseded by AD 2018-18-01
N/A		N/A		N/A - Superseded by AD 2018-26-01
Complied With	Date: 10 Jun 19 ETT: 19,251.53 ETC: 8,413	Open	ETC: 10,013	1. Fan blades replaced with overhauled parts at JES WO# JER4592 and C/W SB 72-1033. TSN/CSN: UNK - 11 x P/N 340-001-036-0, - 01 x P/N 340-001-037-0, - 06 x P/N 340-001-038-0, - 01 x P/N 340-001-039-0 Repeat inspection every 1,600 engine flight cycles after initial inspection due to UNK CSN 2. Fan blades replaced with NEW parts at JES WO# JER4592 - 05 x P/N 340-001-036 S/Ns PC787949, PC816478, PC805087, PC777480, PC816383. USI required at 17,000 engine flight cycles.
Complied With	Date: 10 Jun 19 ETT: 19,251.53 ETC: 8,413	Open	ETC: 10,013	1. Fan blades replaced with overhauled parts at JES WO# JER4592 and C/W SB 72-1033. TSN/CSN: UNK - 11 x P/N 340-001-036-0, - 01 x P/N 340-001-037-0, - 06 x P/N 340-001-038-0, - 01 x P/N 340-001-039-0 Repeat inspection every 1,600 engine flight cycles after initial inspection due to UNK CSN 2. Fan blades replaced with NEW parts at JES WO# JER4592 - 05 x P/N 340-001-036 S/Ns PC787949, PC816478, PC805087, PC777480, PC816383. USI required at 17,000 engine flight cycles.
N/A		N/A		N/A - Superseded by AD 2019-0150

Airworthiness Directive Status Report



Requirements					
AD Ref	SB Ref/Related Info	Title	Effective Date	Supersedure	Tracked Component
2019-0150	72-1074 R1 (CFM56-5B) 72-0794 R1 (CFM56-5C) 72-1042 R1 (CFM56-7B)	Engine - Rotating Air High Pressure Turbine Front Seal - Replacement	05 Jul 19	Supersedes: 2019-0146 Superseded By: 2020-0007	
2019-12-05	72-1042 R1 (-7B) 72-0794 R1 (-5C) 72-1074 R1 (-5B)	ATA 72 – Engine – Rotating Air High Pressure Turbine Front Seal – Replacement	05 Jul 19		
2020-0007	72-1074 R2 (CFM56-5B) 72-1042 R2 (CFM56-7B) 72-0794 R2 (CFM56-5C) *AD 2019-0146 R0* is linked to SB 72-0794 R1	Engine – Rotating Air High Pressure Turbine Front Seal – Replacement	29 Jan 20	Supersedes: 2019-0150	
2020-0044	72-0952 R1 (CFM56-5B) 72-0796 R1 (CFM56-5C) 72-1054 R1 (CFM56-7B)	Engine - High-Pressure Turbine Inner Stationary Seal – Inspection	17 Mar 20		

Last Accomplishment Data		Next Due Data		Method of Compliance
Status		Status		
N/A		N/A		N/A - Superseded by AD 2020-0007
N/A		N/A		N/A to Rotating Air High Pressure Turbine Front Seal P/N 2116M20P02 S/N XAEK9112 installed
N/A		N/A		N/A to Rotating Air High Pressure Turbine Front Seal P/N 2116M20P02 S/N XAEK9112 installed
N/A		N/A		N/A to SEAL-STATIONARY HPT INR STATOR P/N 1808M56G01 S/N ALFPB784 installed, S/N not listed in Table 1 of SB.

Signature

Name

Title

Company

Date

OPERATOR'S COMBINATION STATEMENT

This serves to confirm that during the lease term, operation and redelivery of Engine model CFM56-7B26/3 serial number 896999 by Virgin Australia Airlines:

- 1) Engine was removed in Serviceable Condition: Yes No
If No, please provide all documentation associated with troubleshooting/work accomplished at removal
- 2) The engine and its installed QEC/EBU were delivered in ETOPS configuration and re-delivered in the same modification standard and compliance as when delivered? Yes No *If No, please provide supporting documentation*
- 3) The engine was operated and maintained at an ETOPS Level in accordance with the current OEM manual revision Yes No N/A *If Not an ETOPS Certified Operator mark N/A*
- 4) Were any Fan Blades replaced during the lease term Yes No
If yes, please provide supporting documentation
- 5) Unscheduled Maintenance and/or Inspections were performed during the lease term: Yes No
If yes, please provide supporting documentation
- 6) Were any Engine Operating Limitations reached and/or exceeded during lease term? Yes No
If yes, please provide supporting documentation
- 7) Did the Engine experience any Abnormal Occurrences during lease term, which includes any exposure to radiation where the engine and/or aircraft it was installed on required decontamination?
Yes No *If yes, please provide supporting documentation*
- 8) Was the Engine ever reported to be operating in an Enhanced Procedures Zone (EPZ) or subject to Volcanic Ash Ingestion during lease term? Yes No
If yes, please provide rectification documentation
- 9) Were any Non-OEM Approved Repairs performed on the Engine or its installed QEC?
Yes No *If yes, please provide supporting documentation*
- 10) Were any Non-OEM approved PMA parts installed and/or or incorporated on the Engine or its installed QEC? Yes No *If yes, please provide supporting documentation*
- 11) Were any Non-Type Certificate Holder part(s) or Non-Type Certificate Holder repaired part(s) designated a "Critical Influencing Part" by the respective Engine Type Certificate Holder's "Instructions for Continued Airworthiness" installed on the Engine?
Yes No *If Yes provide details and supporting documentation*
- 12) The Engine was serviced with the following Oil Type(s): Mobil Jet II during the lease term
- 13) An Oil Analysis report was generated during the lease term. Yes No
If yes, please provide supporting documentation
- 14) The Oil Consumption rate was : 0.26 Quarts/hr Pints/hr Liters/hr during the lease term

OPERATOR'S COMBINATION STATEMENT cont'd

15) The Engine was operated using TS-1 Fuels and/or Fuel Additives, this includes but not limited to Kathon FP 1.5 biocide treatment. Yes No *If yes, please list fuel and/or additive type and duration/amount*

16) The engine was operated and maintained in accordance with the Engine and Aircraft manufacturer's practices, procedures and approved data and in accordance with the AMM.

Yes No *If No provide details and supporting documentation for any Deviations from the Manufacturer's approved data*

Engine status at time of Delivery to Virgin Australia Airlines Pty Ltd:

Engine Total Time: 19,251.53 Engine Total Cycles: 8,413 Date: June 14th, 2019

Engine status at time of Cease of Operation & redelivery to VB LeaseCo Pty Ltd:

Engine Total Time: 21,823.62 Engine Total Cycles: 9801 Date: 2 July 2020

Signature: _____

Name: Click or tap here to enter text.

Company: Click or tap here to enter text.

Title: Click or tap here to enter text.

Date: Click or tap to enter a date.

(Note - This document should be certified by an authorized person in QA or Engineering)

To be printed on *Virgin Australia Airlines* letterhead

CERTIFICATION OF OPERATOR INSTALLATION AND REMOVAL HISTORY

To Whom It May Concern:

This is to certify that CFM56-7B26/3, ESN 896999, while operated by Virgin Australia Airlines had the following installation and removal history:

A/C Reg	Pos	TAT	TAC	Engine TSN	Engine CSN	Thrust Rating	Date	Install/Removal
VH-VOT	2	50,793.07	29,989	21,439.75	9,601	7B26/3	Feb 8 th 2020	Installation
VH-VOT	2	51,176.56	30,189	21,823.62	9,801	7B26/3	TBD	Cease of Operation

* As referenced in the Lease Agreement, the above times are noted in decimals

Company: _____

Signature: _____

Name: _____

Title: _____

Date: _____

(Note - This document should be certified by an authorized person in QA or Engineering)

ESN: 896999



General Engine info	
Model and type of engine	CFM56-7B24/3
Current power rating of engine	7B26/3
Engine at date:	8-Jul-2020
Current TSN of engine:	21,823.62
Current CSN of engine:	9,801

Limiting Part Information		
Power Rating	Limiting Part	Cycles Remaining
7B22	Multiple	10,199
7B22/3	Multiple	10,199
7B24/3	Multiple	10,199
7B26/3	Multiple	10,199
7B27/3	Multiple	10,199

LLP Parts

Module Name	Name	Part Number	Serial No	Total Hours	Total Cycles	Cycles Used					Cycles Limit					Cycles Remaining				
						7B22	7B22/3	7B24/3	7B26/3	7B27/3	7B22	7B22/3	7B24/3	7B26/3	7B27/3	7B22	7B22/3	7B24/3	7B26/3	7B27/3
Fan Rotor	Fan Disk	340-000-490-0	PA430320	20,447.09	12,642	11,254	0	0	1,388	0	30,000	30,000	30,000	30,000	30,000	17,358	17,358	17,358	17,358	17,558
Fan Rotor	Fan Booster Spool	340-000-816-0	PA190226	21,823.62	9,801	0	0	3,071	5,322	1,408	23,600	22,900	22,900	22,900	22,900	13,499	13,099	13,099	13,099	13,299
Fan Rotor	Fan Shaft	335-006-414-0	DE172585	21,823.62	9,801	0	0	3,071	5,322	1,408	30,000	30,000	30,000	30,000	30,000	20,199	20,199	20,199	20,199	20,399
HPC Rotor	HPC Stg 1-2 Spool	1558M31G07	GWNOK7KL	21,823.62	9,801	0	0	3,071	5,322	1,408	20,000	20,000	20,000	20,000	20,000	10,199	10,199	10,199	10,199	10,399
HPC Rotor	HPC Stg 3 Disk	2116M23P01	XAEL5977	21,823.62	9,801	0	0	3,071	5,322	1,408	20,000	20,000	20,000	20,000	20,000	10,199	10,199	10,199	10,199	10,399
HPC Rotor	HPC Stg 4-9 Spool	2048M20G03	GWNOK7KE	21,823.62	9,801	0	0	3,071	5,322	1,408	20,000	20,000	20,000	20,000	20,000	10,199	10,199	10,199	10,199	10,399
HPC Rotor	HPC Fwd Shaft	1386M56P03	GWNOK8HA	21,823.62	9,801	0	0	3,071	5,322	1,408	20,000	20,000	20,000	20,000	20,000	10,199	10,199	10,199	10,199	10,399
HPC Rotor	HPC CDP Seal	2116M25P01	GFF5EHE3	21,823.62	9,801	0	0	3,071	5,322	1,408	20,000	20,000	20,000	20,000	20,000	10,199	10,199	10,199	10,199	10,399
HPT Rotor	HPT Disk	1498M43P07	GWNOK92A	21,823.62	9,801	0	0	3,071	5,322	1,408	20,000	20,000	20,000	20,000	20,000	10,199	10,199	10,199	10,199	10,399
HPT Rotor	HPT Front Airseal	2116M20P02	XAEK9112	21,823.62	9,801	0	0	3,071	5,322	1,408	20,000	20,000	20,000	20,000	20,000	10,199	10,199	10,199	10,199	10,399
HPT Rotor	HPT Front Shaft	2048M21P03	XAEM7104	21,823.62	9,801	0	0	3,071	5,322	1,408	20,000	20,000	20,000	20,000	20,000	10,199	10,199	10,199	10,199	10,399
HPT Rotor	HPT Rear Shaft	1864M90P04	TMT6P314	21,823.62	9,801	0	0	3,071	5,322	1,408	20,000	20,000	20,000	20,000	20,000	10,199	10,199	10,199	10,199	10,399
LPT Rotor	LPT Stg 1 Disk	336-001-804-0	DE458706	21,823.62	9,801	0	0	3,071	5,322	1,408	25,000	25,000	25,000	25,000	25,000	15,199	15,199	15,199	15,199	15,399
LPT Rotor	LPT Stg 2 Disk	336-001-909-0	DE660520	21,823.62	9,801	0	0	3,071	5,322	1,408	25,000	25,000	25,000	25,000	25,000	15,199	15,199	15,199	15,199	15,399
LPT Rotor	LPT Stg 3 Disk	336-002-006-0	PA212682	21,823.62	9,801	0	0	3,071	5,322	1,408	25,000	25,000	25,000	25,000	25,000	15,199	15,199	15,199	15,199	15,399
LPT Rotor	LPT Stg 4 Disk	336-002-105-0	PA190295	21,823.62	9,801	0	0	3,071	5,322	1,408	25,000	25,000	25,000	25,000	25,000	15,199	15,199	15,199	15,199	15,399
LPT Rotor	LPT Rotor Support	338-077-502-0	DE693570	21,823.62	9,801	0	0	3,071	5,322	1,408	25,000	25,000	25,000	25,000	25,000	15,199	15,199	15,199	15,199	15,399
LPT Rotor	LPT Shaft	340-074-723-0	DE654848	21,823.62	9,801	0	0	3,071	5,322	1,408	25,000	25,000	25,000	25,000	25,000	15,199	15,199	15,199	15,199	15,399
LPT Rotor	LPT Rear Frame	340-166-211-0	DE049945	21,823.62	9,801	0	0	3,071	5,322	1,408	N/L	N/L	N/L	N/L	N/L	N/L	N/L	N/L	N/L	N/L
LPT Rotor	LPT Case	338-117-407-0	DE476479	21,823.62	9,801	0	0	3,071	5,322	1,408	N/L	N/L	N/L	N/L	N/L	N/L	N/L	N/L	N/L	N/L

Signature: _____

Name: _____

Title: _____

Company: _____

Date: _____

To be printed on *Tigerair Australia* letterhead

ENGINE CERTIFICATION

This statement certifies that Engine CFM56-7B26/3 serial number 896999, has not been involved in an incident or accident, major failure, or fire, nor has the Engine or the parts installed thereon, been immersed in salt water or exposed to corrosive agents outside normal operation, been subjected to extreme stress or heat nor been obtained from any Government, Military or Unapproved Source while Leased and/or Operated by Tigerair Australia, and in the case of a part installed on the engine while Leased and/or Operated by Tigerair Australia, has not been subjected to, or removed from an engine that has been involved in an incident or accident, major failure, or fire, or has been subjected to extreme stress or heat nor been obtained from any Government, Military or Unapproved Source.

No Non-OEM Approved Repairs were performed on the Engine or its installed QEC
No Non-OEM approved PMA parts were installed and/or or incorporated on the Engine or its installed QEC

Engine status at time of Delivery to Tigerair Australia:

Engine Total Time: 19,251.53 Engine Total Cycles: 8,413 Date: June 14th, 2019

Engine status at time of Redelivery to Virgin Australia Airlines Pty Ltd/VB LeaseCo Pty Ltd:

Engine Total Time: 21,439.75 Engine Total Cycles: 9,601 Date: February 5th, 2020

Company: _____

Signature: _____

Name: _____

Title: _____

Date: _____

(Note - This document should be certified by an authorized person in QA or Engineering)



Approved Maintenance Organization Statement

This statement certifies that Virgin Australia & Virgintech are an EASA and/or FAA approved Aircraft Maintenance Organization and is responsible for the Base and Line Maintenance and record keeping for Tigerair Australia.

Virgin Australia & Virgintech technical documentation is therefore considered to be the equivalent of Tigerair Australia technical documentation generated with respect to such Maintenance and records keeping performed for Boeing aircraft engine CFM56-7B26/3 serial number 896999 covering the following period of the Engine’s operation and storage.

Engine status at time of Delivery to Tigerair Australia :

Engine Total Time: 19,251.53 Engine Total Cycles: 8,413 Date: July 4th, 2019

Engine status at time of Redelivery to Virgin Australia:

Engine Total Time: 21,439.75 Engine Total Cycles: 9,601 Date: February 8, 2020

Signature: _____

Name: Click or tap here to enter text.

Title: Click or tap here to enter text.

Company: Click or tap here to enter text.

Date: Click or tap to enter a date.

OPERATOR'S COMBINATION STATEMENT

This serves to confirm that during the lease term, operation and redelivery of Engine model CFM56-7B26/3 serial number 896999 by Tigerair Australia:

- 1) Engine was removed in Serviceable Condition: Yes No
If No, please provide all documentation associated with troubleshooting/work accomplished at removal
- 2) The engine and its installed QEC/EBU were delivered in ETOPS configuration and re-delivered in the same modification standard and compliance as when delivered? Yes No *If No, please provide supporting documentation*
- 3) The engine was operated and maintained at an ETOPS Level in accordance with the current OEM manual revision Yes No N/A *If Not an ETOPS Certified Operator mark N/A*
- 4) Were any Fan Blades replaced during the lease term Yes No
If yes, please provide supporting documentation
- 5) Unscheduled Maintenance and/or Inspections were performed during the lease term: Yes No
If yes, please provide supporting documentation
- 6) Were any Engine Operating Limitations reached and/or exceeded during lease term? Yes No
If yes, please provide supporting documentation
- 7) Did the Engine experience any Abnormal Occurrences during lease term, which includes any exposure to radiation where the engine and/or aircraft it was installed on required decontamination?
Yes No *If yes, please provide supporting documentation*
- 8) Was the Engine ever reported to be operating in an Enhanced Procedures Zone (EPZ) or subject to Volcanic Ash Ingestion during lease term? Yes No
If yes, please provide rectification documentation
- 9) Were any Non-OEM Approved Repairs performed on the Engine or its installed QEC?
Yes No *If yes, please provide supporting documentation*
- 10) Were any Non-OEM approved PMA parts installed and/or or incorporated on the Engine or its installed QEC? Yes No *If yes, please provide supporting documentation*
- 11) Were any Non-Type Certificate Holder part(s) or Non-Type Certificate Holder repaired part(s) designated a "Critical Influencing Part" by the respective Engine Type Certificate Holder's "Instructions for Continued Airworthiness" installed on the Engine?
Yes No *If Yes provide details and supporting documentation*
- 12) The Engine was serviced with the following Oil Type(s): Mobil Jet II during the lease term
- 13) An Oil Analysis report was generated during the lease term. Yes No
If yes, please provide supporting documentation
- 14) The Oil Consumption rate was : 0.26 Quarts/hr Pints/hr Liters/hr during the lease term

OPERATOR'S COMBINATION STATEMENT cont'd

15) The Engine was operated using TS-1 Fuels and/or Fuel Additives, this includes but not limited to Kathon FP 1.5 biocide treatment. Yes No *If yes, please list fuel and/or additive type and duration/amount*

16) The engine was operated and maintained in accordance with the Engine and Aircraft manufacturer's practices, procedures and approved data and in accordance with the AMM.

Yes No *If No provide details and supporting documentation for any Deviations from the Manufacturer's approved data*

Engine status at time of Delivery to Tigerair Australia:

Engine Total Time: 19,251.53 Engine Total Cycles: 8,413 Date: June 14th, 2019

Engine status at time of Redelivery to Virgin Australia Airlines Pty Ltd/VB LeaseCo Pty Ltd:

Engine Total Time: 21,439.75 Engine Total Cycles: 9,601 Date: February 5th, 2020

Signature: _____

Name: Click or tap here to enter text.

Company: Click or tap here to enter text.

Title: Click or tap here to enter text.

Date: Click or tap to enter a date.

(Note - This document should be certified by an authorized person in QA or Engineering)

*To be printed on **VB LeaseCo Pty Ltd** letterhead*

ENGINE COMMERCIAL TRACEABILITY STATEMENT

This statement certifies that Engine Model CFM56-7B26/3 serial number 896999 had the below status at the time of Lease Commencement to Virgin Australia Airlines Pty Ltd/VB LeaseCo Pty Ltd. ESN 896999 was operated by Tigerair Australia & Virgin Australia Airlines Pty Ltd and is being redelivered by VB LeaseCo Pty Ltd to Willis Engine Structured Trust III with the following Engine Redelivery status.

Engine status at time of Delivery to VB LeaseCo Pty Ltd:

Engine Total Time: 19,251.53 Engine Total Cycles: 8,413 Date: June 14th, 2019

Engine status at time of Redelivery to Willis Engine Structured Trust III:

Engine Total Time: 21823.62 Engine Total Cycles: 9801 Date: 2 July 2020

Company: _____

Signature: _____

Name: _____

Title: _____

Date: _____

To be printed on *Tigerair Australia* letterhead

CERTIFICATION OF OPERATOR INSTALLATION AND REMOVAL HISTORY

To Whom It May Concern:

This is to certify that CFM56-7B26/3, ESN 896999, while operated by Tigerair Australia had the following installation and removal history:

A/C Reg	Pos	TAT	TAC	Engine TSN	Engine CSN	Thrust Rating	Date	Install/Removal
VH-VUB	1	51,302.47	21,454	19,251.53	8,413	7B26/3	July 4 th 2019	Installation
VH-VUB	1	53,490.68	22,642	21,439.75	9,601	7B26/3	Feb 5 th , 2020	Removed for Lease Return

* As referenced in the Lease Agreement, the above times are noted in decimals

Company: _____

Signature: _____

Name: _____

Title: _____

Date: _____

(Note - This document should be certified by an authorized person in QA or Engineering)

ESN: 896999



General Engine info	
Model and type of engine	CFM56-7B24/3
Current power rating of engine	7B26/3
Engine at date:	5-Feb-2020
Current TSN of engine:	21,439,75
Current CSN of engine:	9,601

Limiting Part Information		
Power Rating	Limiting Part	Cycles Remaining
7B22	Multiple	10,399
7B22/3	Multiple	10,399
7B24/3	Multiple	10,399
7B26/3	Multiple	10,399
7B27/3	Multiple	10,399

LLP Parts

Module Name	Name	Part Number	Serial No	Total Hours	Total Cycles	Cycles Used		Cycles Used		Cycles Used		Cycles Limit		Cycles Limit		Cycles Remaining		Cycles Remaining		Cycles Remaining	
						7B22	7B22/3	7B24/3	7B26/3	7B27/3	7B22	7B22/3	7B24/3	7B26/3	7B27/3	7B22	7B22/3	7B24/3	7B26/3	7B27/3	
Fan Rotor	Fan Disk	340-000-490-0	PA430320	20,063.22	12,442	11,254	0	1,188	0	30,000	30,000	30,000	30,000	30,000	30,000	17,558	17,558	17,558	17,558	17,558	17,558
Fan Rotor	Fan Booster Spool	340-000-816-0	PA190226	21,439.75	9,601	0	0	3,071	5,122	1,408	23,600	22,900	22,900	22,900	22,900	13,705	13,299	13,299	13,299	13,299	13,299
Fan Rotor	Fan Shaft	335-006-414-0	DE172585	21,439.75	9,601	0	0	3,071	5,122	1,408	30,000	30,000	30,000	30,000	30,000	20,399	20,399	20,399	20,399	20,399	20,399
HPC Rotor	HPC Stg 1-2 Spool	1558M31G07	GWN0K7KL	21,439.75	9,601	0	0	3,071	5,122	1,408	20,000	20,000	20,000	20,000	20,000	10,399	10,399	10,399	10,399	10,399	10,399
HPC Rotor	HPC Stg 3 Disk	2116M23P01	XAEL5977	21,439.75	9,601	0	0	3,071	5,122	1,408	20,000	20,000	20,000	20,000	20,000	10,399	10,399	10,399	10,399	10,399	10,399
HPC Rotor	HPC Stg 4-9 Spool	2048M20303	GWN0K7KE	21,439.75	9,601	0	0	3,071	5,122	1,408	20,000	20,000	20,000	20,000	20,000	10,399	10,399	10,399	10,399	10,399	10,399
HPC Rotor	HPC Fwd Shaft	1386M56P03	GWN0K8HA	21,439.75	9,601	0	0	3,071	5,122	1,408	20,000	20,000	20,000	20,000	20,000	10,399	10,399	10,399	10,399	10,399	10,399
HPC Rotor	HPC CDP Seal	2116M25P01	GFF5EHE3	21,439.75	9,601	0	0	3,071	5,122	1,408	20,000	20,000	20,000	20,000	20,000	10,399	10,399	10,399	10,399	10,399	10,399
HPT Rotor	HPT Disk	1498M43P07	GWN0K92A	21,439.75	9,601	0	0	3,071	5,122	1,408	20,000	20,000	20,000	20,000	20,000	10,399	10,399	10,399	10,399	10,399	10,399
HPT Rotor	HPT Front Airseal	2116M20P02	XAEK9112	21,439.75	9,601	0	0	3,071	5,122	1,408	20,000	20,000	20,000	20,000	20,000	10,399	10,399	10,399	10,399	10,399	10,399
HPT Rotor	HPT Front Shaft	2048M21P03	XAEM7104	21,439.75	9,601	0	0	3,071	5,122	1,408	20,000	20,000	20,000	20,000	20,000	10,399	10,399	10,399	10,399	10,399	10,399
HPT Rotor	HPT Rear Shaft	1864M90P04	TMT16P314	21,439.75	9,601	0	0	3,071	5,122	1,408	20,000	20,000	20,000	20,000	20,000	10,399	10,399	10,399	10,399	10,399	10,399
LPT Rotor	LPT Stg 1 Disk	336-001-804-0	DE458706	21,439.75	9,601	0	0	3,071	5,122	1,408	25,000	25,000	25,000	25,000	25,000	15,399	15,399	15,399	15,399	15,399	15,399
LPT Rotor	LPT Stg 2 Disk	336-001-909-0	DE660520	21,439.75	9,601	0	0	3,071	5,122	1,408	25,000	25,000	25,000	25,000	25,000	15,399	15,399	15,399	15,399	15,399	15,399
LPT Rotor	LPT Stg 3 Disk	336-002-006-0	PA212682	21,439.75	9,601	0	0	3,071	5,122	1,408	25,000	25,000	25,000	25,000	25,000	15,399	15,399	15,399	15,399	15,399	15,399
LPT Rotor	LPT Stg 4 Disk	336-002-105-0	PA190295	21,439.75	9,601	0	0	3,071	5,122	1,408	25,000	25,000	25,000	25,000	25,000	15,399	15,399	15,399	15,399	15,399	15,399
LPT Rotor	LPT Rotor Support	338-077-502-0	DE693570	21,439.75	9,601	0	0	3,071	5,122	1,408	25,000	25,000	25,000	25,000	25,000	15,399	15,399	15,399	15,399	15,399	15,399
LPT Rotor	LPT Shaft	340-074-723-0	DE654948	21,439.75	9,601	0	0	3,071	5,122	1,408	25,000	25,000	25,000	25,000	25,000	15,399	15,399	15,399	15,399	15,399	15,399
LPT Rotor	LPT Rear Frame	340-166-211-0	DE049945	21,439.75	9,601	0	0	3,071	5,122	1,408	NIL	NIL	NIL	NIL	NIL	NIL	NIL	NIL	NIL	NIL	NIL
LPT Rotor	LPT Case	338-117-407-0	DE476479	21,439.75	9,601	0	0	3,071	5,122	1,408	NIL	NIL	NIL	NIL	NIL	NIL	NIL	NIL	NIL	NIL	NIL

Signature: _____
 Name: _____
 Title: _____
 Company: _____
 Date: _____

GARRY FAILLER

16897 NW 16th Street, Pembroke Pines, Florida 33028

Ph: (954)415-5530

garryfailer@gmail.com

Qualifications for Executive-Level Management

Proven aviation executive offering more than 30 years of experience in the industry, progressing from technical operations to executive-level and C Suite management posts. Extensive experience in commercial aircraft leasing, airline operations, aircraft design and aircraft & engine MRO operations. Able to accurately forecast budgets and costs to provide for effective operations as well as business growth. Excellent communications skills and strong P&L experience. Significant experience with regulatory authorities. Extensive understanding of SOX compliance requirements. Citizen of both Canada and the United States.

CAREER HISTORY

AeroTurbine Inc./AerCap Holdings

Chief Operating Officer /Chief Technical Officer

2008 - present

Chief Operating Officer for AeroTurbine, an aviation solutions aftermarket company which is 100% wholly-owned by AerCap Holdings. Responsible for the company's operations worldwide including facilities in the U.S., London and Singapore. Operational responsibilities include engine & aircraft disassembly, warehousing, logistics, EH&S, quality, shipping & receiving, IT, facilities management as well as the company's engine and airframe MRO's. Grew business from \$150M in revenue to over \$500M in 6 years. Also responsible for our in-house commercial aircraft heavy maintenance operations (separate P&L) in Goodyear, Arizona (Phoenix) comprised of 390 employees.

Served as Chief Technical Officer for parent company AerCap Holdings in Amsterdam for 14 months in 2011 – 2012. In this capacity, responsible for all technical aspects of a fleet of 350 commercial lease aircraft including aircraft transitions, lease returns, contract negotiations, purchasing, new aircraft configuration, new engine and airframe selections as well as MRO activities. As a company Director and executive, was a member of the Group Executive Committee at the AerCap Holdings level which set the direction for all divisions/subsidiaries of the company worldwide. Reported directly to the CEO.

AeroThrust Corp.

Executive Vice President – Operations & Engineering

2004 - 2008

Reported directly to the President and responsible for all aspects of the company's engine Maintenance, Repair and Overhaul operations including operational budgets, product quality and contract negotiations. Aided in union negotiations (IAMAW). Improved processes and introduced new product lines into the MRO business. Grew the business significantly and secured several new airline customers worldwide. Responsible manager for the FAA/EASA repair station.

Air Canada

Vice President—Engine Maintenance

2001-2004

Reported directly to the President & CEO of Air Canada Technical Services regarding all aspects of engine maintenance operations and the division's \$300M budget. Served on the executive committee, providing business direction of other technical services and maintenance operations that affected as many as 8,500 employees and a fleet of 250 aircraft. Other technical services included aircraft heavy maintenance and aircraft component MRO's within the company. Assumed role of Six Sigma Master Black Belt. Managed all third-party customer engine MRO work. Oversight of environmental, Health & Safety programs as well as airworthiness compliance issues.

- ⊙ Aided in establishing Air Canada Technical Services as a wholly owned subsidiary of Air Canada and a full-service MRO provider.
- ⊙ Developed a plan that will substantially increase MRO third-party work over a five-year period.
- ⊙ Effectively controlled costs to operate within the \$1B Technical Services budget.
- ⊙ Expanded engine and APU product lines, introducing full repair and overhaul capabilities for four major engine types.

General Manager—Engine Maintenance Centre

1999-2001

Directed the allocation of a \$300M budget and 950 personnel in an engine maintenance facility which repaired and overhauled company-owned and third-party customer engines. Policed all aspects of health and safety. Developed and enhanced labor, corporate and customer relationships.

- ⊙ Reduced engine turn times 50% over two years.
- ⊙ Increased productivity 30% while decreasing power plant unit costs.
- ⊙ Drastically improved labor relations, creating self-directed work teams and establishing the most respected rapport between the industry union (IAMAW) and Air Canada.
- ⊙ Accelerated third-party revenues to over \$100M after driving the expansion of the customer base.

Manager, Propulsion Engineering & Quality

1997-1999

Managed 100 employees engaged in activities related to engine and APU quality, safety, documentation, and engineering. Assigned as the "Core Delegate—Propulsion" by Transport Canada. Ensured compliance with regulations.

- ⊙ Established an advanced work-planning system that predicted cost and material requirements within 2% of the actual budget.
- ⊙ Reorganized the propulsion engineering division, introducing Repair Development Engineering positions that reduced the cost of engine overhauls.

Bombardier Aerospace

Group Leader—Propulsion Systems Engineering

1992-1997

Provided leadership to the CRJ700 Regional Jet design and integration teams in relation to aircraft fuel, propulsion, nacelle, fire detection/extinguishing, and APU systems. Coordinated design efforts with the flight sciences, aerodynamics, structural design, customer support, reliability and maintainability, and core engineering departments. Provided customer service globally, performing onsite visits and in-house redesign activities. Coordinated aircraft flying test bed efforts.

- ⊙ Composed the technical requirement documents for the CRJ-700 propulsion, APU, and aircraft fuel systems.
- ⊙ Drove the successful, on-time delivery of engines and APUs for scheduled aircraft flight tests.

Canadian Airlines International

Propulsion Engineer

1981-1992

Ensured the airworthiness and reliability of power plants installed in company aircraft. Assumed "Delegated Authority" from Transport Canada. Planned, troubleshoot, workscooped, modified, and incorporated project efforts in relation to internal departments and outside repair agencies. Prepared annual operating budgets. Worked independently in Toronto (main hub) in support of the company headquarters in Vancouver.

- ⊙ Achieved the lowest operating cost in the industry for the CF6-50 engine.
- ⊙ Developed workscope specifications for all company engines and APUs, enhancing reliability and lowering costs. Structured and negotiated overhaul agreements with external MRO providers.
- ⊙ Nominated by the executive vice president of the parent company PWA and received a "Top-Flight" award for supporting aircraft and engine sales.

EDUCATION

Southern Alberta Institute of Technology

Engineering Diploma in Aeronautical Engineering
Engineering Diploma in Mechanical Engineering
Extensive miscellaneous Management and Technical training

PROFESSIONAL DEVELOPMENT

Significant experience on a variety of engines and airframes including the B747, B767, B737, A300, A310, A320 family, A330, A340, DC9, Bombardier Regional Jet, PW4000, JT9D, JT8D, RR Trent 700, CF6-50/80, CFM56 family, CF34, and several APU models.

Darren William Dunbier ARN 574691

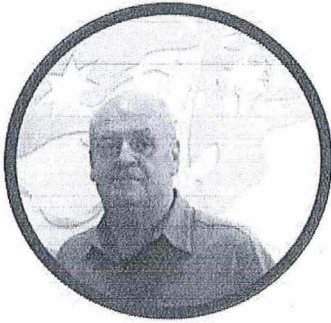

WORK EXPERIENCE

CASA Continuing Airworthiness Manager Part 42 & CASA Accountable Manager part 145

CASA Responsible Manager Technical Operations - Virgin Australia Airlines (2013 to current)

CASA Responsible Manager Technical Operations - Virgin Australia International Airlines (2015 to current)

CASA Maintenance Controller - Virgin Blue Airlines / Virgin Australia Airlines (2008 to current)

CASA HAAMC - Virgin Blue Airlines (2008-2011)

CASA Quality Manager - Virgin Tech (2003 - 2008)/Del. Holder for issue of Transit Authorisation - CASA (2003-08)

Authorised Person for issue of CRS Approvals - CAA Singapore (2004 - 2005);

JAA Approved Quality Manager - Ansett Engine Overhaul, Aircraft Heavy Maintenance and Component

Maintenance (2001 - 2003);

FAA Chief Inspector - Ansett Engine Overhaul (2001 - 2002);

SKILLS

Experienced Engineering & Maintenance Manager across Part 42 (M) Part 145 Aircraft Maintenance & Aeronautical Product.

Completed CASR Part 42 CAMO training and management of airworthiness;

Co-authored and completed Virgin Australia's internal training overview of CASR Part 42;

Comprehensive knowledge of, co-authored and reviewed Virgin Australia's CAME, especially those sections that apply to the role of RM and continuing airworthiness management;

Extensive knowledge of maintenance regulations (Airworthiness Management Vs Maintenance) in relation to aircraft on the VAA AOC and especially that applicable to continuing airworthiness;

Knowledge of the relevant parts of VAA's operations manual that have continuing airworthiness implications for aircraft under its AOC;

Extensive knowledge of aviation maintenance quality management systems.

PROFILE

Experienced Aviation Airworthiness and Maintenance Manager

CONTACT

PHONE:

+6 421 618 798

+61 7 3622 5552

EMAIL:

darren.dunbier@virginaustralia.com

This is Annexure A referred to in the affidavit of Darren William Dunbier

Sworn on

17 July 2020 at Brisbane

Before me

Melissa Jane Bastock
Legal Practitioner



20 July 2020

Derych Christopher Warner
Corporate Office Address:
4700 Lyons Technology Parkway
Coconut Creek, FL 33073

dwarner@willislease.com | D: +1 (858) 812-9763 | M: +1 (858) 337-8311

Occupation: Senior Manager, Customer Liaison

WLFC Hire Date: January 3, 2005

Direct Experience with Technical Records: 15 years

Education:

Arizona State University
Master of Arts-Curriculum and Instruction

Embry Riddle Aeronautical University
Bachelor of Science-Professional Aeronautics
Aviation Safety Certificate

Spartan College of Aeronautics and Technology
Federal Aviation Administration Airframe and Powerplant Certificate

Throughout my tenure with Willis Lease Finance Corporation and 15 years' experience with engine, aircraft and APU leasing/technical records, I have held positions as Technical Records Auditor, Sr. Technical Records Auditor, Manager, Customer Liaison, and Senior Manager, Customer Liaison. I presently have the responsibility of managing the Lease Return Records Department. The fundamental function of this position is to maintain the integrity of WLFC assets by ensuring the procurement and review of all technical documentation is performed to WLFC standards and in accordance with the Lease Agreements.

My duties have consisted of but not limited to:

- Conduct technical record audits on engine models JT8D-200, V2500, RB211, PW2000/4000, CF6-80, CF34, CFM3/5/7, PW100, AE3007, Leap 1A, GE90, GENx and an assortment of APU models
- Perform pre-purchase engine records review for acquisition assessment
- Manage the Technical Records Lease Return Coordination Department
- Perform onsite Part 121 & 145 technical record audits
- Point of contact for Airline and Maintenance Facility technical record queries
- Perform lease return technical documentation procurement and review for the WLFC and managed engine portfolios
- Point of contact for discrepancy resolution of technical documentation with airline and MRO during the lease return process
- Interpret lease agreements to determine lessee's contractual obligations in respect to technical and records return conditions and ensure fulfillment